



22

23

24

25

26

27

28

29

30

31

34

33

35

36

37

38

39

40

42

43

41

32



Master Distributors of SIGN and AWNING Materials & Equipment

Dear Customer,

Welcome to our biggest and best signage catalog ever! Here are the top-quality signage solutions from the very best manufacturers, all clearly described and conveniently organized for your quick reference.

As a loyal S&F customer, you'll enjoy the big savings that you just can't get anywhere else! That's because, as a major signage solutions distributor, we qualify for the very best volume discounts - and we're more than happy to pass the savings along to you! And our huge inventory means that we're able to fill your order fast.

You'll get great service from S&F too, including speedy same-day or next-day delivery, assistance with installation and/or training - plus our friendly, knowledgeable reps who will be happy to answer your questions.

As always, our goal at S&F is to continue to be your one-stop source for all of your sign, awning and digital supply needs. Please note that many more products may be found in our "Awning & Marine Catalog" available at your request.

So please take a few moments to discover what's new, what's improved, and what you need to boost your business. As always, we look forward to serving you.

Sincerely,

S&F Supplies Inc.

Brooklyn Branch 718.399.3333

Upstate NY & NJ Toll Free 1.800.246.8233

Farmingdale Branch 631.420.4400

Long Island Toll Free 1.888.399.1113

Website www.sfsupplies.com Email sales@sfsupplies.com Toll Free Fax 1.888.399.3375

Ordering with S&F is Easy and Convenient

By Phone:

Brooklyn Branch

1-718-399-3333

TOLL FREE:

1-800-246-8233

Long Island Branch

1-631-420-4400

TOLL FREE:

1-888-399-1113

Office Hours: (both locations)

MONDAY - THURSDAY:

8:30 am - 5:30 pm

FRIDAY:

8:30 am - 1:00 pm



A view of our Brooklyn store

By Fax:

Brooklyn & Long Island

TOLL FREE, 24 HOURS:

1-888-399-3375

Please use fax order form on next page for additional discounts

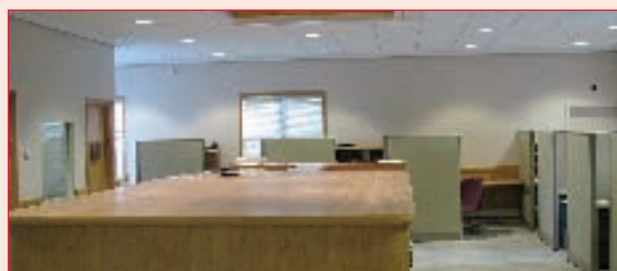

Our state-of-the-art sales offices enables us to fill your orders efficiently

In Person:

S&F Store Brooklyn

110 Emerson Place, Brooklyn NY, 11205

Store Hours:

MONDAY - THURSDAY: 8:00 am - 5:00 pm

FRIDAY: 8:00 am - 1:00 pm

SUNDAY: 9:30 am - 2:00 pm

S&F Store Long Island

43 Engineers Lane, E. Farmingdale NY, 11735

Store Hours:

MONDAY - THURSDAY: 8:00 am - 4:30 pm

FRIDAY: 8:00 am - 1:00 pm

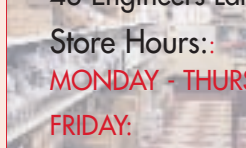

A view of our Farmingdale branch



Digital Graphics showroom at Brooklyn location

By Mail:

S&F Supplies Inc.

P.O. Box 050071

Brooklyn, NY 11205



Online:

www.sfsupplies.com



Our fleet of vans and trucks ensures quick delivery



The S&F Supplies Service Advantage

At S&F Supplies, superior service begins with getting knowledgeable answers to you fast – and then gets even better...



Hate to wait?

So do we! That's why we've made sure that you'll get through to a customer service representative within seconds. They are pleasant, knowledgeable, and ready to help. In fact, that's exactly why they are here!



Fast Shipping

All orders placed in the morning for S&F delivery will be delivered same day, excluding upstate New York, Staten Island & New Jersey. Our re-designed warehouse system is so efficient that your order is picked, packed and on the truck within minutes of your call.



Up-to-the-Minute Pricing.

Our computerized order entry system maintains easy-to-access pricing and order history – even shipping charges. That means less guesswork and no expensive surprises – because we're all about delivering superior customer satisfaction.



Volume Discounts

You get volume discounts on most items in this catalog. You may also mix and match within the same product line to qualify. Please call your Customer Service Representative for details.



Instant Delivery Tracking.

All our trucks are equipped with two-way radio systems for instant tracking. In addition, all shipments with UPS, FedEx, DHL, and other carriers can be tracked on-line.



Expert Technical Support

Need help selecting the best product to meet your sign project? Not sure which printer to buy? What's the best media for your application? Wondering about warranties and specs? Our "signology" experts will be happy to provide you with clear, concise answers – just ask!



Huge Inventory

Our commitment to minimizing backorders is second to none. As such, we maintain one of the most comprehensive inventories in the industry. It's a considerable investment – but we believe that you're worth it!

Terms & Conditions

ORDERING:

Specify catalog number, size, color, thickness, or other description on each item, to avoid shipping errors.

SHIPPING:

Please specify how merchandise should be shipped (UPS, freight, carrier, our truck, etc.). Where no shipping instructions are provided, S&F will ship in the most expedient manner to avoid delay. We deliver free in New York's 5 Boros, Long Island, Upstate NY & NJ. Minimum order

required depending on delivery location. Call S&F for details.

CLAIMS:

Shipments should be inspected immediately upon arrival. If any damages is noticed claim should be made within 5 days after receipt of goods. No merchandise accepted for credit or exchange unless authorized by us.

RETURNS:

Material shipped as ordered can not be returned without S&F's written consent,

and request's must be made within 5 days of delivery. All merchandise must be returned in original packaging. No returns on special orders. No returns on aluminum sheets after customer acceptance.

TERMS:

Products may be ordered C.O.D., cash, visa, master card. To open an account customer must fill out an S&F credit application with three references and a bank reference. For more information call our Accounting Department.

NOT RESPONSIBLE FOR PICTORIAL OR TYPOGRAPHICAL ERRORS.

SF & SUPPLIES

www.sfsupplies.com



INDEX

DIGITAL MEDIA 5

SOLVENT/ECO-SOLVENT

Pressure Sensitive Vinyl.....	6-16
Paper	17
Display Film	18
Canvas/Fabric	19
Banner	20-22

WATER BASED

Paper.....	23-27
Fine Art Paper	28
Display Film	29-31
Pressure Sensitive Vinyl	32-33
Banner	34-35
Canvas/Fabric	36

OVERLAMINATES

Pressure Sensitive/Cold.....	37-41
Liquid Laminate.....	42
Mounting Adhesive	43

SIGN VINYL 45

VINYL AND WRAP SUPPLIES 59

WIDE FORMAT EQUIPMENT 73

VINYL CUTTERS 87

ENGRAVERS 95

SOFTWARE 97

SUBSTRATES 105

BANNER 127

SIGN DISPLAY 139

TAPES & ADHESIVES 145

PAINT 153

NEON SUPPLIES & EQUIPMENT 167

TRANSFORMERS 207

LED SYSTEMS 229

LIGHTING & ELECTRIC 243

SIGN EXTRUSION 267

LETTER & ACCESSORIES 277

MOUNTING HARDWARE 281

EQUIPMENT & SHOP TOOLS 293

Pressure Sensitive Vinyl

White Cast Vinyl

Cast vinyl conforms to curves, rivets etc. and is most commonly used for vehicle wrapping or any other use that needs conformability.

MPI 1005 Supercast films

MPI 1005 Supercast films provide improved conformability along with easy application and long-term removability. Combined with Avery overlaminate films, you'll achieve great printability and colors that pop. MPI 1005 Supercast is available with Gloss Opaque LTR, Easy Apply™ and Easy Apply RS™ technologies to meet most vehicle, fleet graphic or architectural application needs.

- Enhanced conformability for faster and easier installation
- Expanded color gamut capability
- High gloss and smooth face for paint-like finish

MPI 1005 Supercast Gloss Opaque LTR

Long time removeability.

MPI 1005 Supercast Easy Apply™

Easy Apply adhesive system has air egress channels for fast bubble and wrinkle free application.

MPI 1005 Supercast Easy Apply RS™

RS™ adhesive system slides smoothly on surface for exact positioning: stands-off from surface until pressure is applied.

ENHANCED CONFORMABILITY

MPI 1005 EZ RS™
Gloss Supercast Vinyl EZ RS™,
2.1 mil

Adhesive: Gray Permanent, Repositionable, Slideable

Durability: 2 years without laminate, up to 5 years with laminate

MPI 1005 EZ RS

ITEM NO.	SIZE
VAMPI1005RS4850	48" x 150'
VAMPI1005RS5450	54" x 150'
VAMPI1005RS5410	54" x 300'
VAMPI1005RS5425	54" x 75'
VAMPI1005RS6050	60" x 150'
VAMPI1005RS6010	60" x 300'



See page 37 for matching overlaminates

ESM-PWV



Premium Wrap Vinyl, 2.1 mil

An uncoated opaque high gloss cast vinyl that is equipped with Avery Dennison's Easy Apply RS adhesive technology and air egress properties. The specialized adhesive is repositionable and slideable which allows the material to glide across vehicle surfaces for exact graphic placement. Also removes cleanly allowing for reduced labor on vehicle graphic removals.

Adhesive: Gray Permanent, Repositionable, Slideable, LTR

Durability:

ITEM NO.	SIZE
RMESMPWV	30"
RMESMPWV	54"
RMESMPWV	60"

ESM-PCV3



Gloss Premium Cast Vinyl, 2 mil

This premium-quality glossy cast vinyl has a special permanent removable adhesive that is as durable but easier to apply and remove than traditional permanent adhesives. It is extremely durable and conformable to rivets and irregular curves or indentations.

Adhesive: Gray permanent, LTR

Durability: Up to 3 years outdoor

ITEM NO.	SIZE
RMESMPCV38030	30" x 80'
RMESMPCV38054	54" x 80'

Clear Cast Vinyl

UC MPI 1060
(MPI 1020)

Gloss Transparent, 2.1 mil

A clear, high gloss, premium cast vinyl film that offers exceptional value for applications requiring glossy colors and extended durability. It has a clear, permanent adhesive that is removable with heat or chemicals.

Adhesive: Clear Permanent, Repositionable

Durability: 2 years without laminate, 5 years with laminate

ITEM NO.	SIZE
VAMPI10204845	48" x 45'
VAMPI102048150	48" x 150'
VAMPI102048300	48" x 300'
VAMPI102060300	60" x 300'

Black Wrapping Film EZ RS™



Premium Cast Vinyl Film, 2.0 mil

An economical way to cover large areas of solid color.

Adhesive: Clear Permanent, Repositionable, Slideable

Durability: 7 years outdoors

Size: 60" x 150'

ITEM NO.	COLOR
VAWFEZRSBK6050	Black

Pressure Sensitive Vinyl

High Performance Calendered Vinyl



Complete line of large format printing & finishing supplies



DigiJet 973 Gloss White Calendered Vinyl w/AiRFREE, 2.4 mil

AiRFREE technology utilizes embossing patterns on the release liner, making it easier to remove trapped bubbles during application and enhancing adhesion.



Adhesive: Gray
Durability: Up to 5 years outdoor

ITEM NO.	SIZE
DIGIJET97354150	54" x 150'

HP MPI 2005 Easy Apply (MPI 2003)



Matte White Calendered Vinyl, 3.4 mil

A white, low gloss, premium calendered vinyl with a permanent adhesive. It has Easy Apply™ technology which allows air bubbles to be pushed down and out and provides ease of installation.

Adhesive: Clear Permanent, Repositionable, LTR
Durability: 2 years without laminate, up to 5 years with laminate

ITEM NO.	SIZE
VAMPI2003EZ4845	48" x 45'
VAMPI2003EZ48150	48" x 150'
VAMPI2003EZ54150	54" x 150'
VAMPI2003EZ60150	60" x 150'



HP MPI 2105 Easy Apply™/ HP MPI 2105 Easy Apply RS™ High Gloss White Calendered Vinyl, 3.1 mil

Air egress technology helps eliminate wrinkles and bubbles. RS provides repositionability for repositioning of graphic without great force

Adhesive: Gray Permanent, Repositionable, LTR
Durability: Up to 5-year durability unprinted

HP MPI 2105 Easy Apply

ITEM NO.	SIZE
VAMPI2105EZ54150	54" x 150'

HP MPI 2105 Easy Apply RS

Adhesive: Gray Permanent, Repositionable, Slideable, LTR
Durability: Up to 5-year durability unprinted

ITEM NO.	SIZE
VAMPI2105EZRS54150	54" x 150'

VIZUONPRINT™ LG Hausys

LD393TG/LD393TM Gloss White Calendered Vinyl w/AiRFREE, 3.2 mil

A white opaque Gloss PVC film with AiRFREE technology for solvent inkjet printing. AiRFREE technology utilizes embossing patterns on the release liner, making it easier to remove trapped bubbles during application and enhancing adhesion.

Adhesive: Gray Permanent, Repositionable
Durability: Up to five years outdoor



LD393TG Gloss White Calendered Vinyl w/AiRFREE, 3.2 mil

ITEM NO.	SIZE
VLG393TG5450	54" x 150'
VLG393TG6050	60" x 150'

LD393TM Matte White Calendered Vinyl w/AiRFREE, 3.2 mil

ITEM NO.	SIZE
VLG393TM5450	54" x 150'
VLG393TM6050	60" x 150'

Cast or Calendered?

Cast vinyl will be used for vehicle graphic or any other applications where you will need conformability in compound curves or over rivets.

Calendered vinyl is used for many applications including vehicle graphics where it only has flat or simple curves, i.e. bus panels, box truck, etc.



Pressure Sensitive Vinyl

High Performance Calendered Vinyl



DigiJet 980 Series

A premium white matte polymeric calendered vinyl with gray solvent-based pressure sensitive adhesive. For interior or exterior signage, decals, signs, exhibition stands, vehicle advertising.

Adhesive: Gray Permanent

Durability: 5 years outdoor

DigiJet 981

Matte White Calendered Vinyl, w/Permanent Gray Adhesive, 3.2 mil

ITEM NO.	SIZE
DIGIJET98154150	54" x 150'
DIGIJET98160150	60" x 150'

DigiJet 982

Matte White Calendered Vinyl, w/Removable Gray Adhesive, 3.4 mil

ITEM NO.	SIZE
DIGIJET98254150	54" x 150'
DIGIJET98260150	60" x 150'

DigiJet 983

Gloss White Calendered Vinyl, w/Permanent Gray Adhesive, 3.0 mil

ITEM NO.	SIZE
DIGIJET98354150	54" x 150'
DIGIJET98360150	60" x 150'

DigiJet 984

Gloss White Calendered Vinyl, w/Removable Gray Adhesive, 3.0 mil

ITEM NO.	SIZE
DIGIJET98454150	54" x 150'
DIGIJET98460150	60" x 150'



DigiJet 918

Matte White Calendered Vinyl with High Tack Adhesive, 3.2 mil

Designed for interior or exterior signage, decals, nameplates, and point-of-purchase. Bonds to a variety of common substrates used in the graphics applications such as metals, painted metals, plywood, styrene, polyester, polycarbonate etc.

Adhesive: Clear Permanent

Durability: Up to 5 years outdoor

ITEM NO.	SIZE
DIGIJET9183075	30" x 75'
DIGIJET91830150	30" x 150'
DIGIJET9185475	54" x 75'
DIGIJET91854150	54" x 150'
DIGIJET9186075	60" x 75'
DIGIJET91860150	60" x 150'



HP MPI 2102/2103

Gloss White Calendered Vinyl, 3.1 mil

Both HP MPI 2102 and 2103 offer exceptional value for applications requiring premium calendered film durability combined with a permanent or removable adhesive performance. 100% opacity, completely covers whatever is underneath.

Adhesive: Gray

Durability: Up to 5 years unprinted

HP MPI 2102

with Removable Adhesive

ITEM NO.	SIZE
VAMPI210254150	54" x 150'

HP MPI 2103

with Permanent Adhesive

ITEM NO.	SIZE
VAMPI210354150	54" x 150'

HP MPI 2122

(MPI 2012)

Matte White Calendered Vinyl, 3.4 mil

A flexible, matte, calendered vinyl film. Offers exceptional value for applications requiring premium calendered film.

Adhesive: Gray Removable

Durability: 2 years without laminate, up to 5 years with laminate

ITEM NO.	SIZE
VAMPI201254150	54" x 150'
VAMPI201260150	60" x 150'

HP MPI 2120

(MPI 2010)

Matte Permanent, 3.4 mil

A flexible, matte, calendered vinyl film. Offers exceptional value for applications requiring premium calendered film.

Adhesive: Clear Permanent

Durability: 2 years without laminate, up to 5 years with laminate

ITEM NO.	SIZE
VAMPI20103040	30" x 120'
VAMPI201048300	48" x 300'
VAMPI201054150L	54" x 150'
VAMPI201054300	54" x 300'
VAMPI20106050	60" x 150'
VAMPI201060300	60" x 300'



Pressure Sensitive Vinyl

Intermediate Calendered Vinyl

DigiJet 901/903

For interior or exterior signage, this premium calendered vinyl is an excellent choice for many applications.

Adhesive: Clear Permanent
Durability: 3-5 years outdoor



DigiJet 901

Matte White Calendered Vinyl, w/Permanent Adhesive, 3.4 mil

ITEM NO.	SIZE
DIGIJET90130150	30" x 150'
DIGIJET90154150	54" x 150'
DIGIJET90160150	60" x 150'

DigiJet 903

Gloss White Calendered Vinyl, w/Permanent Adhesive, 3.0 mil

ITEM NO.	SIZE
DIGIJET90330150	30" x 150'
DIGIJET90354150	54" x 150'
DIGIJET90360150	60" x 150'



A calendered vinyl film that offers an economical calendered material available for digital printing requirements.

IC MPI 2920 (MPI 3000)

Matte White Calendered Vinyl w/Permanent Adhesive, 3.4 mil

Adhesive: Clear Permanent
Durability: 2 years without laminate, up to 4 years with laminate

ITEM NO.	SIZE
VAMPI30003050	30" x 150'
VAMPI30005450	54" x 150'
VAMPI300054300	54" x 300'
VAMPI30006050	60" x 150'

IC MPI 2921 (MPI 3001)

Matte White Calendered Vinyl w/Removable Adhesive, 3.4 mil

Adhesive: Clear Removable
Durability: 2 years without laminate, up to 4 years with laminate

ITEM NO.	SIZE
VAMPI30015450	54" x 150'
VAMPI30016050	60" x 150'
VAMPI30013050	30" x 150'

IC MPI 2900 (MPI 3100)

Gloss Calendered Vinyl w/Permanent Adhesive, 3.4 mil

A glossy calendered vinyl with a permanent adhesive. Ideal for promotional applications.

Adhesive: Clear Permanent
Durability: 2 years without laminate, up to 3 years with laminate

ITEM NO.	SIZE
VAMPI31003050	30" x 150'
VAMPI310048150	48" x 150'
VAMPI31005450	54" x 150'
VAMPI31006050	60" x 150'



ESM-GCVP/MCVP

A pressure-sensitive calendered vinyl that is durable and water-resistant. The excellent white point of this product along with a relatively high gloss level for GCVP and very low gloss level for MCVP make it a very useful product for a variety of graphic applications that require extended indoor or outdoor life.

Adhesive: Clear Permanent
Durability: Up to 3 years outdoor

ESM-GCVP

Gloss White Calendered Vinyl, Permanent Adhesive, 3 mil

ITEM NO.	SIZE
RMESMGCPV7530	30" x 75'
RMESMGCPV7554	54" x 75'

ESM-MCVP

Matte White Calendered Vinyl, Permanent Adhesive, 3 mil

ITEM NO.	SIZE
RMESMMCVP7530	30" x 75'
RMESMMCVP7554	54" x 75'



VIZUONPRINT™

LD383TG/LD383TM

Gloss White Calendered Vinyl w/AiRFREE, 3.2 mil

A white opaque Gloss PVC film with AiRFREE technology for solvent inkjet printing. AiRFREE technology utilizes embossing patterns on the release liner, making it easier to remove trapped bubbles during application and enhancing adhesion.

Adhesive: Gray Permanent, Repositionable
Durability: Up to three years outdoor

LD383TG

Gloss White Calendered Vinyl w/AiRFREE, 3.2 mil

ITEM NO.	SIZE
VLG383TG5450	54" x 150'
VLG383TG6050	60" x 150'

LD383TM

Matte White Calendered Vinyl w/AiRFREE, 3.2 mil

ITEM NO.	SIZE
VLG383TM5450	54" x 150'
VLG383TM6050	60" x 150'



Pressure Sensitive Vinyl

Intermediate Calendered Vinyl

IC MPI 2902 (MPI 3101)



Gloss Calendered Vinyl w/Removable Gray Adhesive, 3.4 mil

Features an opaque, removable adhesive for mid-term promotions and cover-ups.

Adhesive: Gray Removable

Durability: 2 years without laminate, up to 4 years with laminate

ITEM NO.	SIZE
VAMPI31015450	54" x 150'
VAMPI31016050	60" x 150'

IC MPI 2903 (MPI 3103)



Gloss Calendered Vinyl w/Permanent Gray Adhesive, 3.4 mil

Features an opaque, permanent adhesive for short-term to mid-term promotions and cover-ups.

Adhesive: Gray Permanent

Durability: 2 years without laminate, up to 4 years with laminate

ITEM NO.	SIZE
VAMPI31035450	54" x 150'
VAMPI31036050	60" x 150'

IC MPI 2922 (MPI 3402)



Matte White Calendered Vinyl w/Removable Gray Adhesive, 3.4 mil

A white, flexible, calendered vinyl film that offers a economical calendered material available for digital printing requirements. It is ideal for digital printing applications where print image is not critical.

Adhesive: Gray Removable

Durability: 2 years without laminate, up to 3 years with laminate

ITEM NO.	SIZE
VAMPI34023050	30" x 150'
VAMPI34024850	48" x 150'
VAMPI34026050	60" x 150'

IC MPI 2923 (MPI 3003)



Matte White Calendered Vinyl w/Permanent Gray Adhesive, 3.4 mil

Adhesive: Gray Permanent

Durability: 2 years without laminate, up to 4 years with laminate

ITEM NO.	SIZE
VAMPI30033050	30" x 150'
VAMPI30034850	48" x 150'
VAMPI30035450	54" x 150'
VAMPI30036050	60" x 150'

Intermediate Clear Calendered Vinyl



DigiJet 905/906 Clear Calendered Vinyl, 3.4 mil

For interior or exterior signage, decals, nameplates, die-cut letters and point-of-purchase displays.

Adhesive: Clear

Durability: Up to 3 years outdoor

DigiJet 905 w/Permanent Adhesive

ITEM NO.	SIZE
DIGIJET9055475	54" x 75'
DIGIJET90554150	54" x 150'
DIGIJET90560150	60" x 150'

DigiJet 906 w/Removable Adhesive

ITEM NO.	SIZE
DIGIJET9065475	54" x 75'
DIGIJET90654150	54" x 150'
DIGIJET90660150	60" x 150'

ESM-CCVP Roland DIGITAL GROUP Clear Calendered Vinyl, 3 mil

A pressure-sensitive calendered vinyl that is durable and water-resistant. The excellent print quality and clarity of the vinyl make it useful for a wide variety of graphics that require extended indoor or outdoor life.

Adhesive: Clear Permanent

Durability: Up to 3 years outdoor

ITEM NO.	SIZE
RMESMCCVP7530	30" x 75'
RMESMCCVP7554	54" x 75'



Pressure Sensitive Vinyl

Economical/Promo Calendered Vinyl



DigiJet 970/971

White calendered vinyl for digital printing with clear solvent based adhesive, can be used as wet application. Designed for interior or exterior signage, decals, nameplates, and point-of-purchase displays.

DigiJet 970

Matte w/Permanent Adhesive 3.2mil

Adhesive: Clear Permanent Solvent Based
Durability: Up to 3 years outdoor

ITEM NO.	SIZE
DIGIJET970-SAM	30" x 15'
DIGIJET97030150	30" x 150'
DIGIJET97054150	54" x 150'
DIGIJET97060150	60" x 150'

DigiJet 971

Gloss w/Permanent Adhesive 3.2mil

Adhesive: Clear Permanent Solvent Based
Durability: Up to 3 years outdoor

ITEM NO.	SIZE
DIGIJET971-SAM	30" x 15'
DIGIJET97130150	30" x 150'
DIGIJET97154150	54" x 150'
DIGIJET97160150	60" x 150'



PC MPI 3920 (MPI 3900) PC MPI 3900 (MPI 3910)

An economical promotional vinyl on a 70 lb. StaFlat™ liner.

PC MPI 3920 (MPI 3900)

Matte Calendered Vinyl w/Permanent Adhesive, 3.4 mil

Adhesive: Clear Permanent
Durability: Up to 2 years

ITEM NO.	SIZE
VAMPI39003025	30" x 75'
VAMPI39005450	54" x 150'
VAMPI39006050	60" x 150'

PC MPI 3900 (MPI 3910)

Gloss Calendered Vinyl w/Permanent Adhesive, 3.4 mil

Adhesive: Clear Permanent
Durability: Up to 2 years

ITEM NO.	SIZE
VAMPI39103025	30" x 75'
VAMPI39105450	54" x 150'
VAMPI39106050	60" x 150'



HP MPI 2077 (MPI 2021)

Luster Transparent Ultra-removable, 3.4 mil

A flexible, calendered vinyl film that offers a unique construction ideal for changeable interior and exterior window graphics. Easy and clean removability.

Adhesive: Clear Ultra-Removable
Durability: Up to 1 year

ITEM NO.	SIZE
VAMPI20215450	54" x 150'
VAMPI202154300	54" x 300'



MPI 3601 Quick Mark

White Promotional Calendered Vinyl, 5.9 mil

A 5.9 mil tough, scuff-resistant, flexible, white promotional calendered vinyl film designed specifically for a variety of short term graphic applications such as bus kings, queens, and tails. This high caliper gloss calendered film prints well with most digital solvent, eco-solvent and UV curable inks.

Adhesive: Clear Removable
Durability: Up to 1 year outdoor Printed

ITEM NO.	SIZE
VAMPI36015450	54" x 150'

Floor Advertising Vinyl



DigiJet 910

Floor Advertising Vinyl, 3.4 mil

A specially formulated flexible vinyl with a high performance acrylic pressure sensitive adhesive allows removability of the film from most common floor substrates for up to 6 months. Must be used with "DigiJet 611" overlamine to provide protection to the graphics.

Durability: Up to 6 months removeable

ITEM NO.	SIZE
DIGIJET91054150	54" x 150'



DigiJet 912

Carpet Advertising Vinyl, 3.4 mil

Same as DigiJet 910, but with adhesive especially designed for use on carpet.

Durability: Up to 6 months removeable

ITEM NO.	SIZE
DIGIJET91254150	54" x 150'



Pressure Sensitive Vinyl

White Calendered Vinyl Semi-Rigid, 6 mil

DigiJet 922/923

A general purpose decal film designed for interior or exterior signage, decals, nameplates, die-cut letters and point-of-purchase displays. This semi-rigid vinyl makes applying vinyl easier which will save you time too.

DigiJet 922

Matte w/Permanent Adhesive

Adhesive: Clear Permanent

Durability: Up to 3 years outdoor

ITEM NO.	SIZE
DIGIJET9225475	54" x 75'
DIGIJET92254150	54" x 150'

DigiJet 923

Matte w/Removable Adhesive

Adhesive: Clear Removable

Durability: Up to 3 years outdoor

ITEM NO.	SIZE
DIGIJET92354100	54" x 100'

Wallcovering Vinyl

DigiJet 926

Matte White Calendered Wall Vinyl, 6.0 mil

For temporary application of decals and graphics to most types of painted interior walls and windows. This includes most flat, semi gloss and gloss paint finishes.

Adhesive: Clear Removeable

Durability: Removable up to 1 year

ITEM NO.	SIZE
DIGIJET92654100	54" x 100'

HP MPI 2611 Wall Film (MPI 2601)

Luster White Calendered Wall Vinyl, 6.0 mil

Adhesive: Removable

Durability: 2 years without laminate,
up to 3 years with laminate

ITEM NO.	SIZE
VAMPI26015425	54" x 75'
VAMPI26015450	54" x 150'

Perforated Window Film

DigiJet 950

Perforated Film (50/50) w/Synthetic Liner Clear Adhesive

Smaller hole size makes it ideal for vehicle/fleet window graphics, bus shelters, retail signage, event centers, POP displays and a wide variety of other applications. Use Avery DOL1560 (cast) or DigiJet 631 (calendered) optical clear overlaminating film for extended outdoor durability.

1.5mm Holes, 50/50 film/hole ratio

Adhesive: Clear Removable

Durability: Removable up to 1 year

ITEM NO.	SIZE
DIGIJET9502455	24" x 55'
DIGIJET9503055	30" x 55'
DIGIJET9505455	54" x 55'
DIGIJET95054165	54" x 165'

DigiJet 965

Perforated Film (65/35) w/Synthetic Liner Clear Adhesive

Ideal for exterior-mount window graphics for bus shelters, retail signage, event centers, POP displays and a wide variety of other applications. Use Avery DOL1560 (cast) or DigiJet 631 (calendered) optical clear overlaminating film for extended outdoor durability.

1.6mm Holes, 65/35 film/hole ratio

Adhesive: Clear Removable

Durability: Removable up to 1 year

ITEM NO.	SIZE
DIGIJET9652455	24" x 55'
DIGIJET9653055	30" x 55'
DIGIJET9654855	48" x 55'
DIGIJET96548165	48" x 165'
DIGIJET9655455	54" x 55'
DIGIJET96554165	54" x 165'
DIGIJET9656055	60" x 55'
DIGIJET96560165	60" x 165'



See page 38 for matching overlaminates

HP MPI 2528

(MPI 4002) Perforated Film (50/50), 7 mil

A perforated flexible calendered film for use on one way visual panels. Graphics printed on this material are visible from the front and "invisible" from the back when mounted on windows.

1.5mm Holes, 50/50 film/hole ratio

Adhesive: Black Removable

Durability: Up to 3 years indoor, 1 year outdoor

ITEM NO.	SIZE
VAMPI40024825	48" x 75'
VAMPI40025425	54" x 75'

HP MPI 2728

(MPI 4065) Perforated Film (65/35), 7 mil

1.5mm Holes, 60/35 film/hole ratio

Adhesive: Black Removable

Durability: Up to 3 years indoor, 1 year outdoor

ITEM NO.	SIZE
VAMPI40655425	54" x 75'

PC MPI 3528

(MPI 6250) Perforated Film (50/50), 7 mil

2.0mm Holes, 50/50 film/hole ratio

Adhesive: Black Removable

Durability: Up to 1 year

ITEM NO.	SIZE
VAMPI62505425	54" x 75'

ESM-VTV2

ViewThru Vinyl (60/40), 7 mil

A high-quality calendered vinyl that has been punched with holes. The hole configuration is 60/40. This vinyl has many uses, but particularly for point-of-purchase window signage and vehicle window graphics. Designed to remove cleanly after 1 year.

Adhesive: Clear Removable

Durability: Up to 2 years outdoor

ITEM NO.	SIZE
RMESMVTV25024	24" x 50'
RMESMVTV25053	53" x 50'

Pressure Sensitive Vinyl

Static Cling

DigiJet 907

Clear Static Cling Vinyl, 7.5 mil



For window decals, temporary product markings, point of purchase displays and protective masking. Designed for temporary application to glass. It may also function adequately on other smooth, clean surfaces such as metal and plastics.

Durability: Up to 6 months

ITEM NO.	SIZE
DIGIJET9075475	54" x 75'

DigiJet 908

White Static Cling Vinyl, 7.5 mil



For window decals, temporary product markings, point of purchase displays and protective masking. Designed for temporary application to glass. It may also function adequately on other smooth, clean surfaces such as metal and plastics.

Durability: Up to 6 months

ITEM NO.	SIZE
DIGIJET9085475	54" x 75'

ESM-CSC

Clear Static Cling, 7 mil



A self-clinging clear film which requires no adhesive, applies quickly to glass and most smooth polished surfaces and is easily removed.

ITEM NO.	SIZE
RMESMWSC	54"
RMESMWSC	60"

ESM-WSC

White Static Cling, 7 mil



A self-clinging white film which requires no adhesive, applies quickly to glass and most smooth polished surfaces and is easily removed.

ITEM NO.	SIZE
RMESMWSC	30"
RMESMWSC	54"
RMESMWSC	60"

Translucent Vinyl

DigiJet 985

Translucent Matte White Calendered Vinyl w/Permanent Adhesive, 4.0 mil



A translucent PVC film for solvent inkjet printing. Designed to meet high-resolution printing needs with excellent color for outdoor displays, signs, exhibition stands, vehicle advertising.

Adhesive: Clear Permanent

Durability: Up to 5 years outdoor

ITEM NO.	SIZE
DIGIJET98530150	30" x 150'
DIGIJET9853075	30" x 75'
DIGIJET98554150	54" x 150'
DIGIJET9855475	54" x 75'
DIGIJET98560150	60" x 150'



See next page for more translucent vinyls approved for transit advertising.

IC MPI 2981

Semi-Translucent Matte White Calendered Vinyl, w/Removeable Adhesive 3.4 mil



A white, flexible, calendered vinyl film that offers a economical calendered material available for digital printing requirements. It is ideal for digital printing applications where print image is not critical.

Adhesive: Clear Removable

Durability: Up to 2 years

ITEM NO.	SIZE
3032	48" x 45'
3250	48" x 150'
3002	54" x 45'
3249	60" x 150'

HP MPI 2050 (MPI 2150)

Translucent Matte Calendered Vinyl, 3.2 mil



Adhesive: Permanent

Durability: 2 years without laminate, up to 5 years with laminate

ITEM NO.	SIZE
VAMPI21505425	54" x 75'
VAMPI21505450	54" x 150'
VAMPI21506050	60" x 150'

Some media are affixed strongly to the core and care should be taken to avoid machine issues due to the non-release of media at the end of the roll.

Store media in its original packaging in a cool dry area until ready for processing. If storage conditions are outside the recommended operating ranges, allow the banner material to acclimate in the specified range for at least 24-48 hours before use.



Pressure Sensitive Vinyl

DigiJet 909

MetroMark™ Opaque White Transit Vinyl, 3.4 mil

Opaque White Transit Vinyl with high performance removable adhesive, liner with MetroMark™ logo. For temporary product markings, temporary point of purchase decals, temporary transportation advertising systems, and tri-vision indoor/outdoor billboard displays.

Adhesive: Removable

Durability: Removable for up to one year

ITEM NO.	SIZE
DIGIJET90954150	54" x 150'
DIGIJET90964150	64" x 150'



Transit Vinyl - Opaque

DigiJet 929

SubMark™ Opaque Matte White Transit Vinyl, 3.5 mil

A flexible polymeric matte white opaque vinyl film designed for wall-cut subway poster applications. Excellent outdoor durability. The film provides integrity against removal, helping to prevent vandals from removing from the subway. Designed to bond to a variety of substrates. These films can be used for one, two and three sheet subway advertising posters, architectural signage, commercial-retail signage, industrial identification decals, safety decals, point-of-purchase graphics and other decals requiring extended life.

CBS Outdoor approved for New York subway posters.

Adhesive: Permanent

Durability: Up to five years

ITEM NO.	SIZE
DIGIJET92962150	62" x 150'



HP MPI 2121 Transit Vinyl

White Calendered Vinyl, 3.4 mil

MPI Transit Vinyl is a 3.4 mil, flexible, white, calendered film that has been specifically designed for the temporary transit advertising market. Recommended for both bus advertising panels and direct to bus face.

Adhesive: Removable

Durability: Removable for up to one year

ITEM NO.	SIZE
VAMPI21215450	54" x 150'
VAMPI21216250	62" x 150'



Transit Vinyl - Translucent

DigiJet 924

TransMark® Translucent Vinyl w/Permanent Adhesive, 3.2 mil

A premium white translucent calendared PVC film coated with clear permanent acrylic pressure sensitive adhesive laminated to a 90# layflat liner. Designed for temporary interior or exterior signage applied to illuminated substrates such as polycarbonate, styrene and acrylic sheeting.

Adhesive: Permanent

Durability: Up to five years

ITEM NO.	SIZE
DIGIJET92430150	30" x 150'
DIGIJET92454150	54" x 150'
DIGIJET92460150	60" x 150'



DigiJet 925

TransMark® Translucent Vinyl w/Removeable Adhesive, 3.2 mil

A premium white translucent calendared PVC film coated with clear removable acrylic pressure sensitive adhesive laminated to a 90# layflat liner. Designed for temporary interior or exterior signage applied to illuminated substrates such as polycarbonate, styrene and acrylic sheeting.

Clear Channel approved for taxi top when overlaminated with DigiJet 601 Luster.

Adhesive: Removable

Durability: Removable for up to one year

ITEM NO.	SIZE
DIGIJET92530150	30" x 150'
DIGIJET92554150	54" x 150'
DIGIJET92560150	60" x 150'



DigiJet 928

TransMark® Translucent Vinyl, 6 mil

A premium pressure sensitive decal film with uniform light diffusion properties used to produce backlit displays for applications such as taxi tops, backlit bus displays and any other application requiring back lighting. Offers excellent bond to substrates such as polycarbonate, styrene and acrylic sheeting.

CBS Outdoor and Clear Channel taxi top approved displays.

Adhesive: Removable

Durability: Removable for up to one year

ITEM NO.	SIZE
DIGIJET92854150	54" x 150'
DIGIJET92860150	60" x 150'



Pressure Sensitive Vinyl

Etch Glass



DigiJet 990

Light Glass Etch, 3.0 mil

Designed to give the frosted effect or an impression of etched, cut or sandblasted glass. These films can be used for commercial and residential applications to glass where light transmittance is desired but image transmission is reduced.

Adhesive: Clear Permanent
Durability: Up to 7 years

ITEM NO.	SIZE
DIGIJET990-SAM	30" x 10'
DIGIJET99048150	48" x 150'
DIGIJET99060150	60" x 150'
DIGIJET9906075	60" x 75'



DigiJet 991

Deep Glass Etch, 3.0 mil

Same as DigiJet 990 but has "deep" etch, when more image distortion is desired.

Adhesive: Clear Permanent
Durability: Up to 7 years

ITEM NO.	SIZE
DIGIJET991-SAM	30" x 10'
DIGIJET9913075	30" x 75'
DIGIJET99130150	30" x 150'
DIGIJET99148150	48" x 150'
DIGIJET9916075	60" x 75'
DIGIJET99160150	60" x 150'

Reflective Cast Vinyl

ESM-PRV2



Premium Reflective Cast Vinyl, 6 mil

A pressure-sensitive white reflective, opaque vinyl that combines high-resolution full-color printing with an extremely stable cast vinyl with a permanent adhesive. This is an excellent film for applications requiring engineering grade reflectivity (meets the DOT FP-85 and the ASTM-D 4956-89 specifications).

Adhesive: Permanent
Durability: Up to 3 years outdoor

ITEM NO.	SIZE
RMESMPRV25030	30" x 50'
RMESMPRV25048	48" x 50'

Reflective Perforated

DigiJet 968



Reflective Perforated Vinyl, 9 mil

Silver-gray/black retro-reflective composite PVC with clear removable acrylic pressure-sensitive adhesive and an unperforated solid paper release liner.

1.5mm Holes, 70/30 film/hole ratio

ITEM NO.	SIZE
DIGIJET9682455	24" x 55'
DIGIJET96824165	24" x 165'
DIGIJET9684855	48" x 55'
DIGIJET96848165	48" x 165'

Greenline 3400 series



Avery Dennison EcoFriendly

These products are manufactured using a polyolefin face film, solvent-free emulsion acrylic adhesive and a kraft (wood-free) paper liner. Better for the environment, these films also incorporate top coating ensuring superb printability with UV screen-print, UV curable inkjet & UV offset printing. Available in gloss white, matte white and gloss transparent films.

Adhesive: Clear

GP 3400

Gloss White w/Permanent Adhesive

ITEM NO.	SIZE
VAGP340054165	54" x 165'

Reflective Vinyl

DigiJet 948



White Reflective Engineers Grade

Designed to be used as fleet and vehicle markings, stickers, decals, etc. Best results when applied to flat surfaces, but it can be applied successfully to corrugated surfaces.

ITEM NO.	SIZE
DIGIJET94824150	24" x 150'
DIGIJET9483030	30" x 30'
DIGIJET9483075	30" x 75'
DIGIJET94830150	30" x 150'
DIGIJET9483630	36" x 30'
DIGIJET9483675	36" x 75'
DIGIJET94836150	36" x 150'
DIGIJET9484830	48" x 30'
DIGIJET9484875	48" x 75'
DIGIJET94848150	48" x 150'

SF MPI 6200 Premium Reflective High Gloss, 5.5 mil



Premium, high-gloss reflective cast film optimized to provide consistent, repeatable print performance across all printer platforms.

Adhesive: Silver, Permanent
Durability: 2 years without laminate, up to 5 years with laminate

ITEM NO.	SIZE
VAMPI62004825	48" x 75'
VAMPI62004850	48" x 150'

GP 3401

Gloss White w/Removeable Adhesive

ITEM NO.	SIZE
VAGP340154165	54" x 165'

GP 3420

Matte White w/Permanent Adhesive

ITEM NO.	SIZE
VAGP342054165	54" x 165'

GP 3460

Gloss Clear w/Permanent Adhesive

ITEM NO.	SIZE
VAGP346054165	54" x 165'

Pressure Sensitive Vinyl

SignGold



22K Gold Vinyl Solvent Inkjet Printable

The world's only genuine gold "Print and Cut" media for use with Eco-Solvent, High Solvent and Lyson Inks. Provides superior ink adhesion qualities and extraordinary visual impact. Recommended, for use with integrated Print and Cut equipment, such as Roland's SolJet and Versa Camm series printer/cutters.



Available in Florentine Swirl, Large Engine Turn, XLarge Engine Turn and Glider's Gold.



Florentine Swirl

ITEM NO.	SIZE
SGJFS42	24" x 2 yds.
SGJFS45	24" x 5 yds.
SGJFS50	24" x 10 yds.

Satin Surface

ITEM NO.	SIZE
SGJSS42	24" x 2 yds.
SGJSS45	24" x 5 yds.
SGJSS50	24" x 10 yds.

Large Engine Turn

ITEM NO.	SIZE
SGJLET42	24" x 2 yds.
SGJLET45	24" x 5 yds.
SGJLET50	24" x 10 yds.

Extra Large Engine Turn

ITEM NO.	SIZE
SGJXLET42	24" x 2 yds.
SGJXLET45	24" x 5 yds.
SGJXLET50	24" x 10 yds.



VinylEfx
METALIZED VINYL

Metalized Pressure Sensitive Films Outdoor Durable Series



Metalized films available in an array of patterns. Excellent for signage, decals, labels, nameplate & large-format screen & digital printing applications.

AVAILABLE SIZES:

All patterns

15" x 10 yds. (punched), 15" x 50 yds. (punched), 24" x 10 yds., 24" x 50 yds.

Patterns marked with * are also available in the following sizes

48" x 10 yds., 48" x 50 yds

Adhesive: Permanent

Durability: Up to 5 years outdoor

ITEM NO. DEFX _ _ _ _ (add item number)



WF01 Carbon Fibre Silver*



3102 Smooth Gold*



4402 Florentine Leaf Gold



1967 Lg. Engine Turn Gold*



WF37 Carbon Fibre Black



6501 Fine Brush Silver*



J264 Hammered Leaf Gold



4167 Small Engine Turn Gold*



3101 Smooth Silver*



6502 Fine Brush Gold*



K301 Diamond Plate Silver*



4101 Sm. Engine Turn Silver*

Dry Erase Vinyl

EZ Erase
DRY ERASE VINYL



Writeable Whiteboards

A metalized vinyl film coated with a repositionable, semi-permanent adhesive. For writing and drawing with a wide range of popular dry erase markers. Compatible with eco-solvent, solvent & UV inkjet inks.

Available Sizes: 24" x 30', 24" x 150', 48" x 30', 48" x 150'

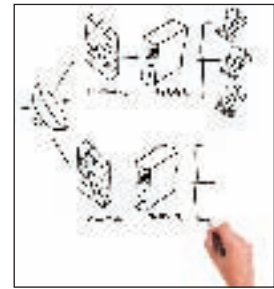

MPI 6121

Street Graphics Film

Matte Finish, 1.8 mil



For promotional short term advertising. MPI 6121 Street Graphics offers exceptional value for creating brand images for **pedestrian and vehicle traffic**, as well as vertical, outdoor textured surfaces. Its unique "micro-fracture" technology enables the film to contour to rough surfaces by fracturing and conforming. perfect for temporary way finding graphics for parades, festivals, and promotional events, such as trade shows and sporting events.

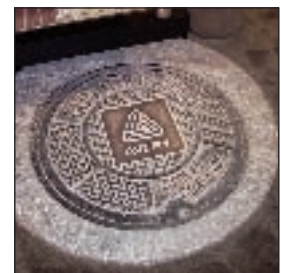

- **Conforms well over highly dimensional surfaces through micro-fracture technology**
- Surface moisture able to move the graphics
- Printed graphics appear to be "painted" onto the substrate
- Outstanding outdoor color durability performance

ITEM NO.	SIZE
VAMPI61212415	24" x 15'
VAMPI612154150	54" x 150'
VAMPI612154300	54" x 300'

DigiJet 701



Glossy Photo Paper, 8 mil

Superior color brilliance and image definition, high whiteness for a wide color gamut. Handles high ink saturation without cockling. Compatible with Eco-Solvent, Solvent, UV Curable & Latex inks.

ITEM NO.	SIZE
DIGIJET70130100	30" x 100'
DIGIJET70136100	36" x 100'
DIGIJET70150100	50" x 100'
DIGIJET70160100	60" x 100'

GFPHOTO

Photo Realistic Glossy Paper, 6 mil



A cost effective solution for printing short-term, high resolution glossy graphics and posters on a solvent based system. Offers a high degree of whiteness and color gamut with an extremely smooth surface for high photographic resolution.

Durability: 1 year+ (indoor)

ITEM NO.	SIZE
IGFPHOTOS30100	30" x 100'
IGFPHOTOS3620	36" x 20'
IGFPHOTOS36100	36" x 100'
IGFPHOTOS50100	50" x 100'
IGFPHOTOS54100	54" x 100'
IGFPHOTOS60100	60" x 100'

Photo Paper

GFPHOTO 240

Photo Realistic Glossy Paper, 8.4 mil



A heavy weight version of the well known and widely used GF Photo. A cost effective solution for printing short-term, high resolution glossy graphics and posters.

Durability: 1 year+ (indoor)

ITEM NO.	SIZE
IGFPHOTO24050100	50" x 100'
IGFPHOTO24060100	60" x 100'

Total Photo™ M

Matte Photorealistic Paper, 6.5 mil



A universal, matte, photorealistic paper for use on both aqueous pigment & dye as well as solvent & eco-solvent printers. Total-Photo™ matte photo paper is constructed with a specialized coating that offers a true universal printing surface and produces matte, photo-quality images.

ITEM NO.	SIZE
ITOTALPHOM36100	36" x 100'
ITOTALPHOM44100	44" x 100'
ITOTALPHOM50100	50" x 100'
ITOTALPHOM50300	50" x 300'
ITOTALPHOM60100	60" x 100'
ITOTALPHOM60300	60" x 300'

SCM-GPPG



Glossy Photobase Paper, 7.5 mil

This high-quality medium weight glossy paper is the perfect receptor for solvent inks with excellent contrast characteristics. It has an excellent white point and gloss level for a wide variety of graphic applications.

ITEM NO.	SIZE
RMSCMGPPG13150	50" x 131'

ESM-SGP3



Solvent Glossy Paper, 8 mil

Heavy weight paper, with an advanced inkjet receptive coating, perfect for high-resolution full-color printing with excellent opacity and white point characteristics.

ITEM NO.	SIZE
RMESMSGP310030	30" x 100'
RMESMSGP310054	54" x 100'
RMESMSGP310063	63" x 100'

PCM-PMP3



Premium Matte Paper, 7 mil

Perfect for high-resolution full-color printing with excellent opacity and white point characteristics. It is matte on the coated side, but has a unique and durable glossy base sheet that stabilizes the product against cockling and excessive curl.

ITEM NO.	SIZE
RMPCMPMP310030	30"x100'
RMPCMPMP310050	50"x100'
RMPCMPMP310060	60"x100'

GFIOP212

Indoor/Outdoor Luster Poster Paper, 9.9 mil



Latex-saturated, wet-strength paper for indoor banners, outdoor posters and wall-coverings. Features a smooth surface which offers exceptional print fidelity with a distinctive luster finish.

Durability: 3-6 months without lamination

ITEM NO.	SIZE
IGFIOP212S5420	54" x 20'
IGFIOP212S54150	54" x 150'
IGFIOP212S54300	54" x 300'
IGFIOP212S60200	60" x 200'

GFIOP140

Indoor/Outdoor Luster Poster Paper, 6 mil



Same as GFIOP212 except for the weight.

Durability: 3-6 months without lamination

ITEM NO.	SIZE
IGFIOP140S48200	48" x 200'
IGFIOP140S5420	54" x 20'
IGFIOP140S54150	54" x 150'
IGFIOP140S4500	54" x 500'
IGFIOP140S60200	60" x 200'
IGFIOP14060500	60" x 500'

POSTERMAX

Latex-Saturated Wet Strength Paper, 8.5 mil



A luster finish one-side coated paper designed to meet the demands of high production Solvent and specifically Eco-Solvent ink jet printers. POSTERMAX resists cracking when folded, and film lamination is not required in most intended applications.

Durability: 3-6 months without lamination

ITEM NO.	SIZE
IPOSMAX54200	54" x 200'
IPOSMAX60200	60" x 200'

Display Film

Bright White Film



POS PRO+ 200

FrontPrint Block-out Film, 10.4 mil



Offers improved BRIGHT WHITE printing surface for added color pop. An anti-curl, block-out polyester film compatible with both aqueous pigment and solvent ink jet printers.

ITEM NO.	SIZE
IPOSPRO2003620	36" x 20'
IPOSPRO20036100	36" x 100'
IPOSPRO20044100	44" x 100'
IPOSPRO20050100	50" x 100'

POS PRO+ 400

FrontPrint Block-out Film, 16.5 mil



An anti-curl, block-out polyester film compatible with both aqueous pigment and solvent ink jet printers. Excellent for pop-up booth graphics.

ITEM NO.	SIZE
IPOSPRO4003620	36" x 20'
IPOSPRO40036100	36" x 100'
IPOSPRO40050100	50" x 100'



Bright White Film, 10 mil

Specifically designed for eco-solvent printers.

Super bright white velvet/matte film. Printable on the matte side. With over 95% opacity, this film provides needed hiding power from distracting shadows. Total solution for tradeshow graphics. This product does not curl on the edges, perfect for use in retractable banner stands.

Sizes available:
36" x 30', 50" x 30' & 54" x 30'



FrontPrint Backlit Film

SBL-7

FrontPrint Backlit Film, 7.0 mil



A backlit film recommended as a front printing and viewing film where high density can be achieved. It is ideal for backlit signage applications, and provides maximum transmitted and reflected ink density, ensuring vivid color and high image resolution.

ITEM NO.	SIZE
ISBL736100	36" x 100'
ISBL742100	42" x 100'
ISBL750100	50" x 100'
ISBL750300	50" x 300'
ISBL754100	54" x 100'
ISBL760100	60" x 100'

GBL-9

FrontPrint Backlit Satin Film, 8.0 mil



A backlit film recommended as a front printing and viewing film where high density can be achieved. It is ideal for backlit signage applications, and provides maximum transmitted and reflected ink density, ensuring vivid color and high image resolution.

ITEM NO.	SIZE
IGBL936100	36" x 100'
IGBL942100	42" x 100'
IGBL954100	54" x 100'
IGBL960100	60" x 100'

ESM-CSF



Clear Solvent Film, 3.0 mil

A high-quality 3 mil clear polyester film. Designed for excellent indoor durability. The excellent print quality and clarity of this film make it useful for a wide variety of specialty graphics including film positives, architectural drawings and overlays.

Durability:

ITEM NO.	SIZE
RMESMCSF6624	24" x 66'
RMESMCSF6648	48" x 66'

SCF-7

Clear Polyester Film, 6.5 mil



A glossy clear polyester film designed for solvent and eco solvent printers. Has excellent image quality and can be used for overlays, clear signage, presentations, and outstanding high black density for making accurate film positives for screen printing.

ITEM NO.	SIZE
ISCF736200	36" x 200'
ISCF754200	54" x 200'
ISCF760100	60" x 100'



Polycarbonate Films

UV & Latex inkjet printable!

Excellent choice for backlit signage and displays, graphic overlay panels, illuminated menu boards and vending machine graphics. Available in 10mil or 15mil which are rigid enough to easily slide into backlit display boxes.

Sizes available:
36" x 30', 50" x 30' & 54" x 30'

Clear, Velvet/Polish Finish Available in 10 mil.

Printable on the polish side.

White, Velvet/Matte Finish Available in 10 mil and 15 mil.

Printable on the matte side.

Canvas • Fabric

Cotton/Polyester Blend Canvas

GFCVM

Matte Artist Stretch Canvas, 17 mil

An acid-free, matte finish, artist stretch canvas designed for long-term, fade resistant fine art or photo reproductions when imaged with solvent inks. The polyester/cotton blend canvas has a specifically designed coating which delivers superior color gamut and resolution.



ITEM NO.	SIZE
IGFCVM3040	30" x 40'
IGFCVM3615	36" x 15'
IGFCVM3675	36" x 75'
IGFCVM5475	54" x 75'
IGFCVM6075	60" x 75'

PCM-MAC7

Matte Artist Stretch Canvas, 18 mil

This medium weight cotton/polyester blend canvas offers an excellent white point and images well in a variety of print modes. Offers exceptional water-resistant properties.



ITEM NO.	SIZE
RMPCMMAC74024	24" x 40'
RMPCMMAC74042	42" x 40'
RMPCMMAC74052	52" x 40'
RMPCMMAC74060	60" x 40'

ESM-SGC

Solvent Gloss Canvas, 22 mil

A waterproof bright white top coated product designed to work with Eco Sol Max ink. The specialized coating offers a high sheen finish, superior color brilliance and excellent image definition. It is composed of a uniform 65% polyester/35% cotton blend that can be stretched without cracking and does not have to be laminated.



ITEM NO.	SIZE
RMESMSGC2530	30" x 25'
RMESMSGC2554	54" x 25'
RMESMSGC5060	60" x 50'

ESM-SSC

Solvent Satin Canvas, 22 mil

Same as ESM-SGC but in satin finish.

ITEM NO.	SIZE
RMESMSSC2530	30" x 25'
RMESMSSC2554	54" x 25'
RMESMSSC5060	60" x 50'

Polyester Fabric

FAB-6

Polyester Fabric Banner, 6.8 mil

An 100% polyester knit woven fabric. Ideal for producing flags, banners, displays, window decorations, pop-up displays, and window backlights.



ITEM NO.	SIZE
IFAB-624150	24" x 150'
IFAB-636150	36" x 150'
IFAB-642150	42" x 150'
IFAB-650150	50" x 150'



Digital Graphics Showrooms

Our showrooms are always set up with the latest models of plotters, large format printers, laminators etc. Our trained technicians are ready to give you a free demonstration on any of the equipment. Please call to schedule an appointment.



Banner

10 OZ. Frontlit
Scrim BannerDigiBan 10 OZ.
Matte Front-Lit Banner

ITEM NO.	SIZE
DIGIBAN1030FL-M	30" x 120'
DIGIBAN1038FL-M	38" x 120'
DIGIBAN1054FL-M	54" x 120'
DIGIBAN1062FL-M	62" x 120'

DigiBan 10 OZ.
Gloss Front-Lit Banner

ITEM NO.	SIZE
DIGIBAN1030FL-G	30" x 120'
DIGIBAN1038FL-G	38" x 120'
DIGIBAN1054FL-G	54" x 120'
DIGIBAN1062FL-G	62" x 120'

SF Banner 10 OZ.
Matte Front-Lit Banner

ITEM NO.	SIZE
SFBA1038FL-M	38" x 165'
SFBA1054FL-M	54" x 165'
SFBA1062FL-M	62" x 165'
SFBA1072FL-M	72" x 165'

SF Banner 10 OZ.
Gloss Front-Lit Banner

ITEM NO.	SIZE
SFBA1038FL-G	38" x 165'
SFBA1054FL-G	54" x 165'
SFBA1062FL-G	62" x 165'
SFBA1072FL-G	72" x 165'



13 OZ. Frontlit Scrim Banner

DigiBan 13 OZ.
Matte Front-Lit Banner

ITEM NO.	SIZE
DIGIBAN1338FL-M	38" x 150'
DIGIBAN1354FL-M	54" x 150'
DIGIBAN1362FL-M	62" x 150'
DIGIBAN1372FL-M	72" x 150'
DIGIBAN1398FL-M	98" x 150'
DIGIBAN13126FLM	126" x 150'

DigiBan 13 OZ.
Gloss Front-Lit Banner

ITEM NO.	SIZE
DIGIBAN1338FL-G	38" x 150'
DIGIBAN1354FL-G	54" x 150'
DIGIBAN1362FL-G	62" x 150'
DIGIBAN1398FL-G	98" x 150'

SFBanner 13 OZ.
Matte Front-Lit Banner

ITEM NO.	SIZE
SFBA1338FL-M	38" x 150'
SFBA1354FL-M	54" x 150'
SFBA1362FL-M	62" x 150'
SFBA1372FL-M	72" x 150'
SFBA1398FL-M	98" x 150'
SFBA13126FL-M	126" x 150'

SFBanner 13 OZ.
Gloss Front-Lit Banner

ITEM NO.	SIZE
SFBA1338FL-G	38" x 150'
SFBA1354FL-G	54" x 150'
SFBA1362FL-G	62" x 150'
SFBA1372FL-G	72" x 150'
SFBA1398FL-G	98" x 150'
SFBA13126FL-G	126" x 150'

ESM-GBV



Glossy Banner Vinyl, 13 oz.

Glossy banner vinyl product designed for high saturated output with a productive yield, at an economy price. This product is ideal for indoor and outdoor applications that call for long-term durability.

ITEM NO.	SIZE
RMESMGBV6630	30" x 66'
RMESMGBV6654	54" x 66'
RMESMGBV6663	63" x 66'

ESM-LBV



Light-Weight Banner Vinyl, 14 mil

This single-sided 13 oz. uncoated scrim banner vinyl is a great all-purpose, low-cost banner alternative for a variety of indoor and outdoor applications. It is very flexible and has a great white point, and can be hemmed and grommeted to finish.

Durability: Up to 3 years outdoor

ITEM NO.	SIZE
RMESMLBV6630	30" x 66'
RMESMLBV6654	54" x 66'
RMESMLBV6673	73" x 66'
RMESMLBV66103	103" x 66'

SCM-SPVCB



Glossy Reinforced Banner, 14 mil

A specially treated reinforced banner material that is extremely durable and water-resistant. The excellent white point of this premium-quality product along with superior tear-resistance make it useful for banner and display graphic applications that require extended indoor or outdoor life. Can be hemmed and grommeted.

Durability: Up to 3 years outdoor

ITEM NO.	SIZE
RMSCMSPVCB6650	50" x 66'
RMSCMSPVCB4973	73" x 49'

One Sided, Blockout Scrim Banner

SF Banner 18 OZ. Matte Blockout Banner

ITEM NO.	SIZE
SFBA18B038-M	38" x 120'
SFBA18B054-M	54" x 120'
SFBA18B062-M	62" x 120'
SFBA18B072-M	72" x 120'
SFBA18B080-M	80" x 120'

ESM-BOSB



BlockOut Scrim Banner, 17 mil

This premium-quality two-sided blockout 20 oz. scrim banner vinyl has a very smooth surface for superior printing on either side. It can be hemmed and grommeted, and the high tenacity polyester base cloth make it extremely dimensionally stable for a wide variety of indoor and outdoor applications.

Durability: Up to 3 years outdoor

ITEM NO.	SIZE
RMESMBOSB6654	54" x 66'

Pre-grommated Banner



Pre-hemmed and pre-grommated banner material designed to go through most digital printers.

Available in the following widths:

54", 44.5",
32.5", 20.5"



Two Sided, Blockout Scrim Banner

SF Banner 15 OZ. Double Sided Matte Blockout Banner

ITEM NO.	SIZE
SFBA15B02S38-M	38" x 120'
SFBA15B02S54-M	54" x 120'
SFBA15B02S62-M	62" x 120'
SFBA15B02S72-M	72" x 120'

VIZUONXIGN™



Block-out Anti-Curl Banner, 14oz

VIZUONXIGN™ is an anti-curl banner material that provides optimal results for both digital and screen printing. It breaks free from the traditional manufacturing method by incorporating PET into the product, leaving out the need for fabric.



- Produces high quality, scratch-resistant graphics
- Smooth, matte, two-sided material, printable on both sides
- Ideal for banner stands, hanging banner displays, exhibits and indoor signage



ITEM NO.	SIZE
VLGXIGN3933	39" x 99'
VLGXIGN5433	54" x 99'

Vinyl Coated Mesh



DigiMesh White with Liner, 12x12

ITEM NO.	SIZE
SFBAMESHL54	54" x 105'
SFBAMESHL62	62" x 105'
SFBAMESHL72	72" x 105'
SFBAMESHL87	87" x 105'



Backlit Banner

SF Banner 20 OZ. Gloss Backlit Banner

ITEM NO.	SIZE
SFBA20BL54-G	54" x 105'
SFBA20BL62-G	62" x 105'
SFBA20BL80-G	80" x 105'
SFBA20BL98-G	98" x 105'

Exotic

Back-Lit Fabric

A vinyl coated, polyester, reinforced fabric finished with a laminated vinyl top surface.

ITEM NO.	SIZE	WIEGHT
AWF1200-54	54" x 75'	15 oz.
AWF1200	60" x 150'	15 oz.
AWF5000N	80" x 75'	16 oz.

DMiBOP10

Wet Strength Banner Paper, 11 mil



An economical, latex-saturated nylon-reinforced cellulose, wet-strength indoor banner/outdoor poster and wallcovering material. Resists water and UV damage.

ITEM NO.	SIZE
IIBOP103675	36" x 75'
IIBOP1036125	36" x 125'
IIBOP104275	42" x 75'
IIBOP105075	50" x 75'
IIBOP1050125	50" x 125'
IIBOP105475	54" x 75'
IIBOP106075	60" x 75'



Banner

Polypropylene Banner

STICK 2™

**Polypropylene
with a Low-tack PSA, 7 mil**



A polypropylene banner with a low-tack, pressure-sensitive adhesive that is repositionable, removable, and may be reapplied to most surfaces. Has a truly universal ink jet coating that makes it compatible with; solvent, eco-solvent, aqueous pigment, aqueous dye, and UV curable inks.

ITEM NO.	SIZE
ISTICK236100	36" x 100'
ISTICK236500	36" x 500' 6" core
ISTICK242100	42" x 100'
ISTICK250100	50" x 100'
ISTICK250500	50" x 500' 6" core

GFPPOLY

**Glossy Polypropylene
Banner, 8 mil**



A glossy polypropylene banner for indoor, outdoor, and roll up applications and is specifically designed for solvent and eco-solvent ink jet printers. GFPPOLY is a cost effective solution for printing short-term, high resolution glossy graphics, banners, P.O.P. displays, roll up displays, and posters.

Durability:

ITEM NO.	SIZE
IGFPOLY30100	30" x 100'
IGFPOLY3630	36" x 30'
IGFPOLY36100	36" x 100'
IGFPOLY42100	42" x 100'
IGFPOLY54100	54" x 100'
IGFPOLY60100	60" x 100'

PPM7 (GFPPM7)

**Matte Polypropylene
Banner, 9 mil**



An economical polypropylene durable banner material that resists water and UV damage. Produces high quality images on a matte finish. Can be used for both indoor and outdoor applications.

Durability: 6 months indoor and 1 month outdoor

ITEM NO.	SIZE
IPPM72460	24" x 60'
IPPM73610	36" x 10'
IPPM73660	36" x 60'
IPPM736100	36" x 100'
IPPM74260	42" x 60'
IPPM75060	50" x 60'
IPPM750100	50" x 100'
IPPM76060	60" x 60'



VSF

**Valeron Strength
Film Banner, 12 mil**



This strong recyclable material is plasticizer-free, vinyl-free, recyclable, and stronger than most scrim vinyls in the market today. Designed for use with pigmented, solvent and UV Cure inks in durable outdoor banner applications.

ITEM NO.	SIZE
IVSF2450	24" x 50'
IVSF3650	36" x 50'
IVSF3675	36" x 75'
IVSF4250	42" x 50'
IVSF5050	50" x 50'
IVSF5450	54" x 50'
IVSF5475	54" x 75'

TB9 (GFTB9)

**Tyvek® Indoor/Outdoor
Banner, 9 mil**



A 9 mil polyolefin banner grade of TYVEK® that resists water and UV damage. This product is tear resistant, which makes it perfect for longterm indoor or outdoor banner applications.

Durability: Outdoor; 3 months - Indoor; 6 months

ITEM NO.	SIZE
IGFTB93610	36" x 10'
IGFTB936100	36" x 100'
IGFTB942100	42" x 100'
IGFTB95475	54" x 75'

#1401

GLEN RAVEN

Vivitex FR Banner

**2 Side Printable,
Coated Polyester, 9.6 oz.**

An oxford weave polyester fabric which is coated on both sides with an inkjet receptive topcoat for use in most solvent, eco-solvent and UV inkjet printers.

ITEM NO.	SIZE
DSUN14016025	60" x 75'
DSUN14016050	60" x 150'

#1663

GLEN RAVEN

**Poly Oxford White
Polyester Oxford Fabric, 8 oz.**

An Oxford weave polyester fabric with a white inkjet receptive topcoat, for use with most solvent, Eco-Solvent, and UV printers.

ITEM NO.	SIZE
DSUN16636025	60" x 75'
DSUN16636050	60" x 150'

#1665

GLEN RAVEN

**Sunbrella Inkjet White
Solution Dyed Acrylic Fabric,
10 oz.**

Fabric has a white inkjet receptive topcoat, for use with most solvent, Eco-Solvent, and UV printers.

ITEM NO.	SIZE
DSUN16656025	60" x 75'
DSUN16656050	60" x 150'

Photobase Paper for Dye Based Ink

MUL-7

Luster Photobase Paper, 7 mil

Economical, resin-coated photobase, bright white lustre compatible with most ink jet printers.

Ink Compatibility: Dye based inks

ITEM NO.	SIZE
IMUL73610	36" x 10'
IMUL736100	36" x 100'
IMUL742100	42" x 100'
IMUL750100	50" x 100'
IMUL760100	60" x 100'



MUG-7

Glossy Photobase Paper, 7 mil

Economical, resin-coated photobase, bright white glossy compatible with most ink jet printers.

Ink Compatibility: Dye based inks

ITEM NO.	SIZE
IMUG73610	36" x 10'
IMUG736100	36" x 100'
IMUG742100	42" x 100'
IMUG750100	50" x 100'
IMUG760100	60" x 100'



Premium 270g

Photographic Glossy Paper, 10 mil

Prints with bold dynamic colors on a heavy-weight base for high-quality photographic output.

Ink Compatibility: Dye based inks

ITEM NO.	SIZE
K08717423	36" x 100'
K01363076	42" x 100'
K01694447	50" x 100'
K01889062	60" x 100'



Premium 180g

A medium-weight photographic paper with a smooth finish for high-quality photographic output.

Photographic Glossy Paper, 8 mil

Ink Compatibility: Dye based inks

ITEM NO.	SIZE
K01177781	24" x 100'
K01790203	36" x 100'
K01393768	42" x 100'
K08582967	50" x 100'
K08669475	60" x 100'



Photographic Satin Paper, 8 mil

Ink Compatibility: Dye based inks

ITEM NO.	SIZE
K01439942	24" x 100'
K08542003	36" x 100'
K08599185	42" x 100'
K01638436	50" x 100'
K08833782	60" x 100'

Photographic Matte Paper, 8 mil

Ink Compatibility: Dye based inks

ITEM NO.	SIZE
K01171099	24" x 100'
K08876310	36" x 100'
K08094807	42" x 100'
K08558926	50" x 100'
K01323245	60" x 100'

S&F
Your Complete Source for
LARGE FORMAT
Printers & Media
Billboards...



Visit the S&F
Digital Graphics Showroom

Paper

Photobase Paper for Dye Based/Pigmented Inks

Siena 200L/200G

Features thinner caliper for reliable feed through ALL printers. Unique coating on a resin-coated photobase paper makes it compatible with piezo and thermal ink jet printers with pigment and dye inks.

Siena 200L (DMPDQU-L)
Luster Photobase Paper,
8 mil

Ink Compatibility: Dye based/pigmented inks



ITEM NO.	SIZE
ISIENA200L24100	24" x 100'
ISIENA200L3610	36" x 10'
ISIENA200L42100	42" x 100'
ISIENA200L44100	44" x 100'
ISIENA200L50100	50" x 100'
ISIENA200L60100	60" x 100'

Siena 200G (DMPDQU-G)
Gloss Photobase Paper,
8 mil

Ink Compatibility: Dye based/pigmented inks



ITEM NO.	SIZE
ISIENA200G24100	24" x 100'
ISIENA200G3610	36" x 10'
ISIENA200G36100	36" x 100'
ISIENA200G42100	42" x 100'
ISIENA200G44100	44" x 100'
ISIENA200G60100	60" x 100'

Siena 250L/250G

The latest development in resin-coated photobase papers for high-speed thermal and piezo ink jet printers equipped with either dye or pigmented inks. Features extremely vibrant colors and instant dry times, even with pigmented inks.

Siena 250L (DMPDQ2-L)
Luster Photobase Paper,
9.4 mil

Ink Compatibility: Dye based/pigmented inks



ITEM NO.	SIZE
ISIENA250L2490	24" x 90'
ISIENA250L3610	36" x 10'
ISIENA250L3690	36" x 90'
ISIENA250L4490	44" x 90'
ISIENA250L5090	50" x 90'
ISIENA250L5490	54" x 90'
ISIENA250L6090	60" x 90'

Siena 250G (DMPDQ2-G)
Gloss Photobase Paper,
9.4 mil

Ink Compatibility: Dye based/pigmented inks



ITEM NO.	SIZE
ISIENA250G2490	24" x 90'
ISIENA250G3610	36" x 10'
ISIENA250G3690	36" x 90'
ISIENA250G4490	44" x 90'
ISIENA250G5090	50" x 90'
ISIENA250G5490	54" x 90'
ISIENA250G6090	60" x 90'

Rapid-Dry 190g **Kodak**
Wide-Format Inkjet Media

Provides excellent image quality and instant dry times. Outstanding color density and wide color gamut.

Photographic Glossy Paper,

Ink Compatibility: Dye based/pigmented inks

ITEM NO.	SIZE
KO222730	24" x 100'
KO222731	36" x 100'
KO222732	42" x 100'
KO222733	50" x 100'
KO222734	60" x 100'

Photographic Satin Paper, 190g

Ink Compatibility: Dye based/pigmented inks

ITEM NO.	SIZE
KO222737	24" x 100'
KO222738	36" x 100'
KO222739	42" x 100'
KO222740	50" x 100'
KO222741	60" x 100'

Rapid-Dry 260g **Kodak**
Wide-Format Inkjet Media

Offers the ideal weight, thickness and finish for high quality photographic reproductions. Superb color image quality and guaranteed performance for longevity.

Premium Photographic Glossy Paper,

Ink Compatibility: Dye based/pigmented inks

ITEM NO.	SIZE
KO00081A	24" x 100'
KO00082A	36" x 100'
KO00080A	42" x 100'

Premium Photographic Luster Paper, 260g

Ink Compatibility: Dye based/pigmented inks

ITEM NO.	SIZE
KO00071A	24" x 100'
KO00072A	36" x 100'
KO00070A	42" x 100'



Photo Realistic

DMPS150

**Semi-Gloss
Photorealistic Paper, 5 mil**

Photo quality output on an economical photorealistic paper. This non resin-coated photographic paper provides a rich, smooth texture.

Ink Compatibility: Dye based inks

ITEM NO.	SIZE
IPS15024100	24" x 100'
IPS15036100	36" x 100'
IPS15042100	42" x 100'
IPS15050100	50" x 100'
IPS15060100	60" x 100'



Production 170g **Kodak**

Wide-Format Inkjet Media

Designed for low-cost, short-term indoor graphics, such as vivid posters, photorealistic image reproduction, and professional trade show graphics.

Photographic Glossy Paper, 7 mil

Ink Compatibility: Dye based inks

ITEM NO.	SIZE
KO222763	36" x 100'
KO222764	42" x 100'
KO222765	50" x 100'
KO222766	60" x 100'

Photographic Satin Paper, 7 mil

Ink Compatibility: Dye based inks

ITEM NO.	SIZE
KO222768	36" x 100'
KO222769	42" x 100'
KO222770	50" x 100'
KO222771	60" x 100'

Total Photo™ M

**Matte Photorealistic
Paper, 6.5 mil**

A universal, matte, photorealistic paper for use on both aqueous pigment & dye as well as solvent & eco-solvent printers. Total-Photo™ matte photo paper is constructed with a specialized coating that offers a true universal printing surface and produces matte, photo-quality images.

Ink Compatibility: Dye based/pigmented inks

ITEM NO.	SIZE
ITOTALPHOM36100	36" x 100'
ITOTALPHOM44100	44" x 100'
ITOTALPHOM50100	50" x 100'
ITOTALPHOM50300	50" x 300'
ITOTALPHOM60100	60" x 100'
ITOTALPHOM60300	60" x 300'



PCM-PMP3 **Roland**

DIGITAL GROUP

Premium Matte Paper, 7 mil

Perfect for high-resolution full-color printing with excellent opacity and white point characteristics. It is matte on the coated side, but has a unique and durable glossy base sheet that stabilizes the product against cockling and excessive curl.

Ink Compatibility: Pigmented and mild solvent

ITEM NO.	SIZE
RMPCMPMP310030	30" x 100'
RMPCMPMP310050	50" x 100'
RMPCMPMP310060	60" x 100'



Learn more about our many fine products at our website

www.sfsupplies.com

In addition to item description and specs you can view large detailed images of all the items



MasterCatalog.pdf

A PDF version of our Master Catalog is available on our site for you to download



Paper

Self Adhesive Photobase Paper

Siena 200L/200G PSA

You can generate the same high quality images as you can with the Siena 200L/200G. These papers are adhesive-backed which will eliminate a production step.

Siena 200L PSA (DMPDQU-LPSA)



Luster Photobase Paper, 8 mil w/Pressure Sensitive Adhesive

Ink Compatibility: Dye based/pigmented inks

ITEM NO.	SIZE
ISIENA200LPSA2450	24" x 50'
ISIENA200LPSA3650	36" x 50'
ISIENA200LPSA4250	42" x 50'
ISIENA200LPSA5050	50" x 50'
ISIENA200LPSA5450	54" x 50'
ISIENA200LPSA6050	60" x 50'

Siena 200G PSA (DMPDQU-GPSA)



Gloss Photobase Paper, 8 mil w/Pressure Sensitive Adhesive

Ink Compatibility: Dye based/pigmented inks

ITEM NO.	SIZE
ISIENA200GPSA2450	24" x 50'
ISIENA200GPSA3650	36" x 50'
ISIENA200GPSA4250	42" x 50'
ISIENA200GPSA5050	50" x 50'
ISIENA200GPSA5450	54" x 50'
ISIENA200GPSA6050	60" x 50'

DMPLA7/DMPHA7

A permanent, pressure-sensitive adhesive added to a universal resin-coated low glare photobase paper. The polyethylene resin coated surface prevents paper cockle and yields photorealistic images.

DMPLA7

Low Glare Photobase Paper w/Pressure Sensitive Adhesive, 7 mil

Ink Compatibility: Dye based inks

ITEM NO.	SIZE
IPLA73650	36" x 50'
IPLA74250	42" x 50'
IPLA75050	50" x 50'
IPLA75450	54" x 50'
IPLA76050	60" x 50'

DMPHA7

High Gloss Photobase Paper, w/Pressure Sensitive Adhesive, 7 mil

Ink Compatibility: Dye based inks

ITEM NO.	SIZE
IPHA73650	36" x 50'
IPHA74250	42" x 50'
IPHA75050	50" x 50'
IPHA75450	54" x 50'
IPHA76050	60" x 50'

Self Adhesive Coated Paper



Coated Matte 140g

Self Adhesive Coated Matte Print Paper, 7 mil

A versatile coated matte paper that offers a permanent adhesive backing for easy mounting on a range of smooth surfaces. Economically priced for short-term indoor applications, its no-glare matte surface is ideal for packaging prototypes and self-adhesive posters.

Ink Compatibility: Dye based/pigmented inks

ITEM NO.	SIZE
KO8330052	36" x 100'
KO1920487	42" x 100'
KO1937010	50" x 100'
KO8078081	60" x 100'



Self Adhesive Photo Paper

Poly Poster Plus Kodak Wide-Format Inkjet Media Satin Self-Adhesive, 6 mil

This Poly Poster media has a high tack adhesive which forms a strong permanent bond with various substrate types for a variety of applications. It provides an exceptional white point and offers high ink capacity for excellent saturation.

Ink Compatibility: Dye based/UV Inks

ITEM NO.	SIZE
KO223213	36" x 100'
KO223214	42" x 100'
KO223215	50" x 100'
KO223216	60" x 100'

Poly Poster Plus Kodak Wide-Format Inkjet Media Glossy Self-Adhesive, 6 mil

This Poly Poster media has a high tack adhesive which forms a strong permanent bond with various substrate types for a variety of applications. It provides an exceptional white point and offers high ink capacity for excellent saturation.

Ink Compatibility: Dye based/UV Inks

ITEM NO.	SIZE
KO223208	36" x 100'
KO223209	42" x 100'
KO223210	50" x 100'
KO223211	60" x 100'

Need help selecting the right product?

The knowledgeable sales team at S&F will be able to assist and advise you in choosing the product that will best fit your application.



Coated Paper

DMPG98 98g

Coated Matte Presentation Paper, 4.4 mil

Economical, lightweight coated matte paper compatible with most ink jet printers. Offers high opacity, bright white appearance, and optimal color gamut.

Ink Compatibility: Dye based/pigmented inks

ITEM NO.	SIZE
IPG9824150	24" x 150'
IPG9836150	36" x 150'
IPG9836300	36" x 300'
IPG9842150	42" x 150'
IPG9842300	42" x 300'
IPG9844150	44" x 150'
IPG9854150	54" x 150'
IPG9860150	60" x 150'
IPG9860300	60" x 300'



Firenze 132 132g (DMPG132)

Coated Matte Presentation Paper, 6.5 mil

Economical, mid-weight coated matte paper compatible with most ink jet printers. Offers high opacity, bright white appearance, and optimal color gamut. **2-side imageable.**

Ink Compatibility: Dye based/pigmented inks

ITEM NO.	SIZE
IFIREN13236100	36" x 100'
IFIREN13236300	36" x 300'
IFIREN13242100	42" x 100'
IFIREN13244100	44" x 100'
IFIREN13254100	54" x 100'
IFIREN13260100	60" x 100'



JSO-36

Coated Matte Paper, 6.4 mil

Heavyweight coated ink jet paper for full color presentations where added stiffness and stability are required.

Ink Compatibility: Dye based inks

ITEM NO.	SIZE
IJSO3636100	36" x 100'
IJSO3654100	54" x 100'
IJSO3660200	60" x 200'



JSO-24

Coated Matte Paper, 4.5 mil

Coated ink jet paper designed for use in CAD and full-color plots. This bright, white paper offers the broadest range of attainable colors. Excellent for color output on most CAD ink jet printer systems.

Ink Compatibility: Dye based inks

ITEM NO.	SIZE
IJSO2424150	24" x 150'
IJSO2430150	30" x 150'
IJSO2436150	36" x 150' 4pk
IJSO2436300	36" x 300'
IJSO2442150	42" x 150'
IJSO2442300	42" x 300'
IJSO2450150	50" x 150'
IJSO2460300	60" x 300'



Firenze 170 170g (DMPG170)

Coated Matte Presentation Paper, 8 mil

Economical, heavyweight coated matte paper compatible with most ink jet printers. Offers high opacity, bright white appearance, and optimal color gamut.

Ink Compatibility: Dye based/pigmented inks

ITEM NO.	SIZE
IFIREN1702490	24" x 90'
IFIREN1703690	36" x 90'
IFIREN1704290	42" x 90'
IFIREN1705090	50" x 90'
IFIREN1705490	54" x 90'
IFIREN1706090	60" x 90'



Matchprint M120DP

Coated Matte Paper, 6 mil

An economical, 120 g/m2 matte-coated media for single-sided imposition and content proofing.

Ink Compatibility: Dye based/pigmented inks

ITEM NO.	SIZE
KO30002501	24" x 100'
KO30002502	36" x 150'
KO30002503	42" x 150'
KO30002504	60" x 150'



Coated Matte 90g Kodak Coated Matte Print Paper, 4 mil

A versatile media economically priced for short-term indoor applications. It is lightweight, easy to fold, and boasts an ink-receiving coating that delivers truly brilliant colors. Ideal for proofs, maps, charts etc.

Ink Compatibility: Dye based/pigmented inks

ITEM NO.	SIZE
KO8759268	24" x 100'
KO1051028	36" x 100'
KO8980096	42" x 100'
KO8518615	50" x 100'



Coated Matte 140g Kodak Coated Matte Print Paper, 6 mil

A versatile media economically priced for short-term indoor applications. It is lightweight, easy to fold, and boasts an ink-receiving coating that delivers truly brilliant colors. Ideal for proofs, maps, charts etc.

Ink Compatibility: Dye based/pigmented inks

ITEM NO.	SIZE
KO1660661	24" x 100'
KO1839208	36" x 100'
KO8811721	42" x 100'
KO8294498	50" x 100'
KO8332199	60" x 100'

Matchprint M150DP

Coated Matte Paper, 7 mil

An economical 150 g/m2 matte-coated media for single-sided imposition and content proofing.

Ink Compatibility: Dye based/pigmented inks

ITEM NO.	SIZE
KO30002505	24" x 100'
KO30002506	36" x 100'
KO30002507	42" x 100'
KO30002508	50" x 100'
KO30002509	60" x 100'

Fine Art Paper

Verona 250 HD 250g High Definition Smooth Fine Art Paper



Offers clean sharp images with an exceptional color gamut. The smooth surface allows for extremely vibrant colors as well as beautifully defined blacks and gray tones. This 250-gram, smooth, matte finish, 100% cotton paper designed specifically for fine art applications.

Ink Compatibility: Dye based/pigmented inks

ITEM NO.	SIZE
IVERONA2502435	24" x 35'
IVERONA2503635	36" x 35'
IVERONA2504435	44" x 35'
IVERONA2505035	50" x 35'

Verona 285T High Definition Textured Fine Art Paper



A 285 gram paper made of 100% cotton liners with a textured finish and a traditional matte finish designed for long-term fade resistant reproductions. This bright, white fine art paper is acid-free and lignin-free which results in a high archival quality.

Ink Compatibility: Dye based/pigmented inks

ITEM NO.	SIZE
IVERONA285T2435	24" x 35'
IVERONA285T3635	36" x 35'
IVERONA285T4235	42" x 35'
IVERONA285T4435	44" x 35'
IVERONA285T5035	50" x 35'

Fine Art Fibre Paper



An ideal glossy or satin finish base with the look and feel of traditional photographic fibre bases of the past.

Ink Compatibility: Pigmented inks

Fine Art Fibre Glossy

ITEM NO.	SIZE
KO00123A	24" x 50'
KO00124A	36" x 50'
KO00125A	44" x 50'

Fine Art Fibre Satin

ITEM NO.	SIZE
KO00113A	24" x 50'
KO00114A	36" x 50'
KO00116A	44" x 50'

Fine Art Coated Matte Paper



A high quality, heavy-weight, matte surface paper designed for photographic and fine art reproductions, as well as for graphic and commercial printing. Bright white, matte surface is ideal for framing, display and exhibition. Acid free and lignin free.

Ink Compatibility: Pigmented inks

ITEM NO.	SIZE
KO00103A	24" x 100'
KO00104A	36" x 100'
KO00106A	44" x 100'

Fine Art Textured Paper



A premier quality, heavy-weight and textured base with the look and feel of a traditional artists' paper for fine art and photographic reproductions. Acid and Lignin free 100% cotton base and specially formulated coating provide excellent color and long-term image durability with a variety of pigmented inks.

Ink Compatibility: Pigmented inks

ITEM NO.	SIZE
KO00131A	24" x 50'
KO00132A	36" x 50'
KO00133A	44" x 50'

Fine Art Smooth Paper



A premier quality, heavy-weight and silky smooth matte surface base specially formulated for fine art and photographic reproductions. Acid and Lignin free 100% cotton base provides excellent color, image quality and long-term image durability with a variety of pigmented inks.

Ink Compatibility: Pigmented inks

ITEM NO.	SIZE
KO00140A	24" x 50'
KO00141A	36" x 50'
KO00142A	44" x 50'



Display Film

FrontPrint Backlit Film

SBL-7

FrontPrint Backlit Film, 7.0 mil



A backlit film recommended as a front printing and viewing film where high density can be achieved. It is ideal for backlit signage applications, and provides maximum transmitted and reflected ink density, ensuring vivid color and high image resolution.

ITEM NO.	SIZE
ISBL736100	36" x 100'
ISBL742100	42" x 100'
ISBL750100	50" x 100'
ISBL750300	50" x 300'
ISBL754100	54" x 100'
ISBL760100	60" x 100'

DMBL5

FrontPrint Backlit Film, 6.5 mil



Instant dry backlit film. The satin print surface allows for maximum ink density, vivid color and the highest image resolution for back-lit viewing in both indoor and outdoor applications. Offers excellent color and transmissive density with pigmented water-based inks.

Ink Compatibility: Pigmented inks

ITEM NO.	SIZE
IDMBL536100	36" x 100'
IDMBL542100	42" x 100'
IDMBL550100	50" x 100'
IDMBL560100	60" x 100'

Premium Backlit Film



Glossy Translucent Backlit Film, 7 mil

A translucent polyester film providing high image quality and robust handling properties. It is ideal for durable, scratch-resistant backlit displays in high-traffic location.

Ink Compatibility: Dye based inks

ITEM NO.	SIZE
KO8507097	36" x 100'
KO8934101	42" x 100'
KO1563428	50" x 100'
KO1937846	60" x 100'

Production Backlit Film



FrontPrint Backlit Film, 7 mil

Offers vivid colors and an exceptional white point for short-term, front-print, backlit applications. The inkjet coating is designed to provide exceptional saturation at an attractive price for any job.

Ink Compatibility: Dye based inks

ITEM NO.	SIZE
KO222778	36" x 100'
KO222779	42" x 100'
KO222780	50" x 100'
KO222781	60" x 100'

Universal Backlit Film



FrontPrint Backlit Film, 8 mil

This heavy weight front print backlit provides excellent pigment and dye image quality, high-speed drying and universal compatibility at a competitive price.

Ink Compatibility: Dye based/pigmented inks

ITEM NO.	SIZE
KO222773	36" x 100'
KO222774	42" x 100'
KO222775	50" x 100'
KO222776	60" x 100'

Profiling Backlit Film

When creating profiles for media that is viewed by transmissive light, use transmission measurement devices.

Transmission measurement devices, especially those which are strip readers, often need to be calibrated several times before they are ready to take density readings.

If a transmission measurement device is not available, acceptable profiles can be created with a reflective device by placing the media printed side up on white paper when making measurements. Results may be slightly lighter and less saturated than when a true transmission device is used, but it will provide you with a good starting point and, if necessary, you can adjust the brightness

and colors with your RIP or image manipulation software.

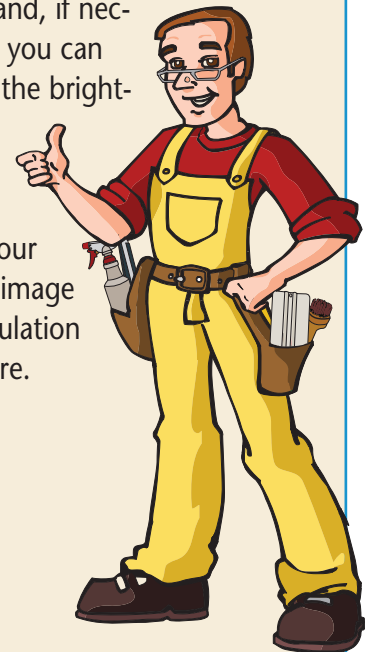

Display Film

BackPrint (Reverse Image) Backlit Film

DMBP5
BackPrint Polyester Film, 5.8 mil



This versatile backprint film prints reverse on the matte side so your image is protected without the need to overlamine

Ink Compatibility: Dye based/pigmented inks

ITEM NO.	SIZE
IBP524100	24" x 100'
IBP536100	36" x 100'
IBP542100	42" x 100'
IBP544100	44" x 100'
IBP550100	50" x 100'
IBP554100	54" x 100'
IBP560100	60" x 100'

DMBPC12
BackPrint Backlit/Fronlit Polycarbonate Film, 12 mil



This polycarbonate rigid, matte film provides vivid color for backlit and frontlit viewing that does not require over lamination. By reverse imaging on the matte surface, the polycarbonate surface protects the image while its texture naturally diffuses light and cuts glare. The stiffness of the polycarbonate base makes it easy to slide into display boxes or to make panels for rigid displays.

Ink Compatibility: Dye based/pigmented inks

ITEM NO.	SIZE
IBPC122460	24" x 60'
IBPC123660	36" x 60'
IBPC124260	42" x 60'
IBPC125060	50" x 60'

Reverse Print Backlit Film **Kodak**
BackPrint Backlit Film, 6 mil



Offers excellent image durability due to its high-gloss, scratch-resistant coating. Brilliant color images can be printed in reverse on the coated side of the film and displayed in light boxes, lit window displays or other backlit applications indoors or outdoors. **Compatible with piezo and thermal dye (reverse print) and pigmented inks (direct print).**

Ink Compatibility: Dye based/pigmented inks

ITEM NO.	SIZE
K01893064	36" x 100'
K08794828	42" x 100'
K01578194	50" x 100'
K01446830	60" x 100'



Clear Film

DMCF4HPS
Clear Polyester Film for HP Printers, 4 mil



A clear polyester film featuring removable edge stripes specifically for Hewlett-Packard printers that require edge media sensing.

Ink Compatibility: Dye based/pigmented inks

ITEM NO.	SIZE
ICF4HPS2475	24" x 75'
ICF4HPS3675	36" x 75'
ICF4HPS4275	42" x 75'
ICF4HPS5475	54" x 75'
ICF4HPS6075	60" x 75'

Novara CF
Clear Gloss Polyester Film, 5.4 mil



Perfect for silkscreen applications

A perfect solution for film positives in silkscreen applications. Has a slight level of opacity to eliminate the need for edge stripes with optical sensing printers.

Ink Compatibility: Pigmented inks

ITEM NO.	SIZE
INOVARA24100	24" x 100'
INOVARA36100	36" x 100'
INOVARA50100	50" x 100'
INOVARA60100	60" x 100'

PQM-CPF **Roland**
Clear PET Film, 5 mil **DIGITAL GROUP**

Exceptional dot definition for high-resolution printing Ideal for all types of overlays and specialty graphics.

Ink Compatibility: Dye based/pigmented inks

ITEM NO.	SIZE
RMPQMCPF6642	42" x 66'
RMPQMCPF6652	52" x 66'
RMPQMCPF66459	59" x 66'

The quality of a backlit display is very dependent on the quality of the light box used. Although typically out of the print-providers control, it is worth some effort to investigate the type of light box to be used for both uniformity of light and color quality. When possible evaluate prints under similar conditions.



Display Film

White Film

Palermo SPF

Satin Photo Film, 7.2 mil

A satin tear resistant photo realistic film designed for aqueous pigment ink. Offers optimum image quality and quick drying for easy handling and finishing. Offers a universal solution for many of today's most popular graphics and displays, as well as indoor banner graphics and backlit displays.

Ink Compatibility: Dye based/pigmented inks



ITEM NO.	SIZE
IPALERMO24100	24" x 100'
IPALERMO36100	36" x 100'
IPALERMO50100	50" x 100'
IPALERMO60100	60" x 100'

PQM-PETG



Super Hi Gloss White Film, 5 mil

This durable, high-gloss white polyester film with exceptional dot definition for highest resolution printing makes this a must for photography and high profile presentations. This product is water-resistant [water-fast] and also exhibits quick dry properties.

Ink Compatibility: Dye based/pigmented inks

ITEM NO.	SIZE
RMPQMPETG6641	41" x 66'
RMPQMPETG6652	52" x 66'
RMPQMPETG6659	59" x 66'

Production Poly Poster Plus



Gives you the look of photographic media without the high price. Durable, versatile and tear-resistant, these media are an excellent choice for producing indoor banners.

Ink Compatibility: Dye based/pigmented inks

Glossy Poly Poster Plus, 8mil

ITEM NO.	SIZE
KO222540	36" x 100'
KO222541	42" x 100'
KO222542	50" x 100'
KO222543	60" x 100'

Satin Poly Poster Plus, 8mil

ITEM NO.	SIZE
KO222547	36" x 100'
KO222548	42" x 100'
KO222549	50" x 100'
KO222550	60" x 100'

Premium White Film



Glossy Opaque Frontlit Film, 5 mil

Provides exceptional durability and high gloss for front-lit displays. Especially suitable for long-term indoor displays.

Ink Compatibility: Dye based inks

ITEM NO.	SIZE
KO8500456	36" x 100'
KO1918440	42" x 100'
KO8836843	50" x 100'
KO1568443	60" x 100'

Universal Poly Poster.



Ideal for advertising and displays with excellent saturation and durable color. Compatible with modern pigment based inkjet printers, these water resistant media are available in both glossy and satin finishes.

Glossy White Film, 8mil

ITEM NO.	SIZE
KO00202A	36" x 100'
KO00204A	50" x 100'
KO00205A	60" x 100'

Satin White Film, 8mil

ITEM NO.	SIZE
KO00208A	36" x 100'
KO00210A	50" x 100'
KO00211A	60" x 100'

Self-Adhesive Poly Poster



Self-Adhesive Glossy White Film, 7mil

ITEM NO.	SIZE
KO00214A	36" x 100'
KO00216A	50" x 100'
KO00217A	60" x 100'

Self-Adhesive Satin White Film, 7mil

ITEM NO.	SIZE
KO00220A	36" x 100'
KO00222A	50" x 100'
KO00223A	60" x 100'

Bright White Film

POS PRO+

Offers improved BRIGHT WHITE printing surface for added color pop. An anti-curl, block-out polyester film compatible with both aqueous pigment and solvent ink jet printers.

Ink Compatibility: Pigmented inks

POS PRO+ 200

FrontPrint Block-out Film, 10.4 mil

ITEM NO.	SIZE
IPOSPRO2003620	36" x 20'
IPOSPRO20036100	36" x 100'
IPOSPRO20044100	44" x 100'
IPOSPRO20050100	50" x 100'

POS PRO+ 400

FrontPrint Block-out Film, 16.5 mil

Ink Compatibility: Pigmented inks

ITEM NO.	SIZE
IPOSPRO4003620	36" x 20'
IPOSPRO40036100	36" x 100'
IPOSPRO40050100	50" x 100'



Pressure Sensitive Vinyl

Digi Inkjet



Matte Calendered Vinyl w/Permanent Adhesive, 4.5 mil



A water resistant calendered white PVC vinyl with a matte non glare finish. For indoor and outdoor use. Excellent color brilliance and image definition. Works great with the HP Z6100.

Ink Compatibility: Dye based/pigmented inks

ITEM NO.	SIZE
DIGIUVMP2475	24" x 75'
DIGIUVMP3675	36" x 75'
DIGIUVMP4275	42" x 75'
DIGIUVMP5075	50" x 75'
DIGIUVMP6075	60" x 75'

DMVLA5

White Opaque, Matte Calendered Vinyl w/Permanent Adhesive, 5 mil



Excellent for printing flexible, durable signs and banners. Perfect for mounting to smooth surfaces.

Ink Compatibility: Pigmented inks

ITEM NO.	SIZE
IVLA52440	24" x 40'
IVLA53640	36" x 40'
IVLA53675	36" x 75'
IVLA54240	42" x 40'
IVLA54440	44" x 40'
IVLA55040	50" x 40'
IVLA55075	50" x 75'
IVLA55440	54" x 40'
IVLA56040	60" x 40'

White Calendered Vinyl

Water Resistant Removable Vinyl 6mil



Easy removable up to six months from most smooth surfaces. The right choice for non-permanent window displays and temporary advertising.

Ink Compatibility: Pigmented inks

ITEM NO.	SIZE
KO221621	36" x 60'
KO221622	42" x 60'
KO221623	50" x 60'
KO221624	60" x 60'

Water Resistant Self-Adhesive Vinyl



Matte Calendered Vinyl w/Permanent Adhesive, 6 mil

Easily mounted on most smooth surfaces. Comes with an incredible Performance Guarantee of up to five years.

Ink Compatibility: Pigmented inks

ITEM NO.	SIZE
KO1757558	36" x 40'
KO1329739	42" x 40'
KO1378967	50" x 40'
KO8868093	60" x 40'

Production Removable Vinyl



Features an adhesive specially formulated to allow repositioning at time of install. It is intended to be mounted on walls, glass or other permanent fixtures for short term indoor display applications. Exceptional white point and high ink capacity provide vivid colors for a range of point of sale advertising. Removable up to six months.

Ink Compatibility: Pigmented inks

Gloss, 6mil

ITEM NO.	SIZE
KO223218	36" x 60'
KO223219	42" x 60'
KO223220	50" x 60'
KO223221	60" x 60'

Satin, 6mil

ITEM NO.	SIZE
KO223223	36" x 60'
KO223224	42" x 60'
KO223225	50" x 60'
KO223226	60" x 60'

Pressure Sensitive Vinyl

White Calendered Vinyl

IPM 2100 (IPM 2001)

Gloss White Calendered Vinyl, 3.2 mil

A flexible, calendered vinyl designed for excellent inkjet print receptivity on many popular wide format ink jet printers.

Ink Compatibility: Dye based inks

ITEM NO.	SIZE
VAIPM20013660	36" x 60'
VAIPM20015060	50" x 60'

IPM 2120EZ (IPM 2000EZ)

Matte White Calendered Vinyl, 3.2 mil

A flexible, calendered vinyl designed for excellent inkjet print receptivity on many popular wide format ink jet printers. Easy Apply feature offers the benefits of reduced wrinkling and air entrapment inherent in the application of graphics.

Ink Compatibility: Dye based/pigmented inks

ITEM NO.	SIZE
VAIPM2000EZ36	36" x 45'
VAIPM2000EZ50	50" x 45'
VAIPM2000EZ54	54" x 45'
VAIPM2000EZ60	60" x 45'

IPM 2120 (IPM 2500)

Premium Matte White Calendered Vinyl w/Permanent Adhesive, 3.4 mil

Ink Compatibility: Dye based/pigmented inks

ITEM NO.	SIZE
VAIPM25003645	36" x 45'
VAIPM25004245	42" x 45'
VAIPM25005045	50" x 45'
VAIPM25005445	54" x 45'
VAIPM25006045	60" x 45'

IPM 2121 (IPM 2501)

Premium Matte White Calendered Vinyl w/Removable Adhesive, 3.4 mil

A flexible, calendered vinyl designed for excellent ink jet print receptivity on many popular wide format ink jet printers. Recommended for many applications such as wall murals, short-term indoor and outdoor signs, art reproductions and point-of-purchase displays.

Ink Compatibility: Dye based/pigmented inks

ITEM NO.	SIZE
VAIPM25013645	36" x 45'
VAIPM25014245	42" x 45'
VAIPM25015045	50" x 45'
VAIPM25015445	54" x 45'
VAIPM25016045	60" x 45'

IPM 3020 (IPM 3500)

Economy Matte White Calendered Vinyl w/Permanent Adhesive, 3.4 mil

Recommended for many applications such as wall murals, short-term indoor and outdoor signs, art reproductions and point-of-purchase displays.

Ink Compatibility: Dye based/pigmented inks

ITEM NO.	SIZE
VAIPM35003645	36" x 45'
VAIPM35005445	54" x 45'
VAIPM35006045	60" x 45'



When handling Avery Dennison™ IPM products, it is recommended that cotton gloves be worn to prevent fingerprints or other contamination. Avery Dennison™ IPM products are sensitive to pressure, moisture, and oils from the skin.

For indoor and short-term outdoor use, a clear overlamine film is recommended for Avery Dennison™ IPM products to provide water resistance, abrasion resistance and UV fade resistance. Be sure the printed ink is dry to the touch before laminating. Note that drying time may need to be extended in cooler temperatures and high humidity conditions. Avery Dennison™ IPM products may be sensitive to moisture curl, so it is best to laminate between 30 minutes and 24 hours after printing.

Finished graphics should be wound face out with a minimum inner diameter of 6 inches. Keeping the inner diameter at 6 inches or larger will prevent the graphic from tunneling.



Banner

Polypropylene Banner

PPM7 (DMPPM7; GFPPM7)

Polypropylene Matte Banner, 9 mil



An economical polypropylene durable banner material that resists water and UV damage. Produces high quality images on a matte finish. Can be used for both indoor and outdoor applications.

Ink Compatibility: Pigmented inks

ITEM NO.	SIZE
IPPM72460	24" x 60'
IPPM73610	36" x 10'
IPPM73660	36" x 60'
IPPM736100	36" x 100'
IPPM74260	42" x 60'
IPPM75060	50" x 60'
IPPM750100	50" x 100'
IPPM76060	60" x 60'

PPM7 PSA (DMPPM7 PSA)

Polypropylene Matte Banner w/Permanent Adhesive, 11 mil



A low cost polypropylene banner with a permanent, pressure-sensitive adhesive. Ideal for short-term indoor and outdoor applications.

Ink Compatibility: Pigmented inks

ITEM NO.	SIZE
IPPM7PSA3660	36" x 60'
IPPM7PSA4260	42" x 60'
IPPM7PSA5060	50" x 60'

DMPB10-C2S

2-Sided Polyethylene Banner, 10 mil



This is a 2-side coated, universal printer and ink compatible Magic ink jet banner that allows both sides to be imaged and viewed from either side. This two-sided banner offers a lower cost than printing on an one-sided banner and stitching it back-to-back.

Ink Compatibility: Dye based/pigmented inks

ITEM NO.	SIZE
IPB10-C2S3675	36" x 75'
IPB10-C2S4275	42" x 75'
IPB10-C2S5075	50" x 75'
IPB10-C2S5475	54" x 75'
IPB10-C2S6075	60" x 75'

STICK 2™

Polypropylene with a Low-tack PSA, 7 mil



A polypropylene banner with a low-tack, pressure-sensitive adhesive that is repositionable, removable, and may be reapplied to most surfaces. Has a truly universal ink jet coating that makes it compatible with; solvent, eco-solvent, aqueous pigment, aqueous dye, and UV curable inks.

ITEM NO.	SIZE
ISTICK236100	36" x 100'
ISTICK236500	36" x 500' 6" core
ISTICK242100	42" x 100'
ISTICK250100	50" x 100'
ISTICK250500	50" x 500' 6" core

Tyvek Banner



TB9 (DMTB9)

Tyvek Banner, 9 mil



A 9 mil polyolefin banner grade of TYVEK® that resists water and UV damage. This product is tear resistant, which makes it perfect for longterm indoor or outdoor banner applications.

Ink Compatibility: Pigmented inks

ITEM NO.	SIZE
ITB93650	36" x 50'
ITB936100	36" x 100'
ITB94250	42" x 50'
ITB95050	50" x 50'
ITB950100	50" x 100'
ITB95450	54" x 50'
ITB96050	60" x 50'

Water Resistant Poly Poster

Matte, 8mil



This tear-resistant base with a low-glare matte finish offers excellent durability and image quality. Ideal for low-cost, short-term outdoor banners and signs as well as day/night displays. Perfect for grommeting, sewing or addign wind slits. Both permanent adhesive and non-adhesive versions are available.

Water Resistant Poly Poster Matte, 8 mil

ITEM NO.	SIZE
KO220061	36" x 100'
KO220062	42" x 100'
KO220063	50" x 100'
KO220064	60" x 100'

Water Resistant Self Adhesive Poly Poster, Matte, 9mil

ITEM NO.	SIZE
KO220067	36" x 100'
KO220068	42" x 100'
KO220069	50" x 100'
KO220070	60" x 100'

PCM-WTBM



Tyvek Banner Material, 9 mil

This Tyvek-base material is water-fast, light weight, and outdoor durable. Excellent for event banners. Its high white point characteristics make it suitable for high-quality retail display applications.

Ink Compatibility: Dye based/pigmented inks

ITEM NO.	SIZE
IMPCMPVCB5042	42" x 50'
IMPCMPVCB5050	50" x 50'
IMPCMPVCB5060	60" x 50'

Scrim Banner

DMVB15 Premium Scrim Vinyl Banner, 15.5 mil



A premium scrim, outdoor/indoor banner material with an opaque, tear-resistant, polyester scrim sandwiched between two PVC layers. Resists water and UV damage. Drapes easily.

Ink Compatibility: Dye based/pigmented inks

ITEM NO.	SIZE
IVB152440	24" x 40'
IVB153640	36" x 40'
IVB153675	36" x 75'
IVB154250	42" x 50'
IVB154275	42" x 75'
IVB155050	50" x 50'
IVB155075	50" x 75'
IVB155350	53" x 75'
IVB156050	60" x 50'

DMVB14 One-Sided Scrim Vinyl Banner, 14.6 mil



An economical, one-sided scrim banner vinyl for indoor or outdoor applications. Same image quality and waterfastness/lightfastness as the DMVB15, with only slightly less physical durability and flexibility.

Ink Compatibility: Dye based/pigmented inks

ITEM NO.	SIZE
IVB142440	24" x 40'
IVB143640	36" x 40'
IVB143675	36" x 75'
IVB144250	42" x 50'
IVB145050	50" x 50'
IVB145075	50" x 75'
IVB145450	54" x 50'
IVB146050	60" x 50'

PCM-PVCB Scrim Banner Material, 15 mil

Based on a standard PVC scrim banner cloth, this product is coated on one side to be Piezo Certified. In addition to the extremely durable properties of the base product, this media exhibits an excellent white point and exceptional image quality.

Ink Compatibility: Dye based/pigmented inks

ITEM NO.	SIZE
RMPKMPVCB5042	42" x 50'
RMPKMPVCB5050	50" x 50'
RMPKMPVCB5060	60" x 50'

Water Resistant Scrim Banner 17mil

This reinforced material with a polyester scrim center creates an extremely durable, tear-resistant structure that offers 100% opacity with a smooth imaging surface for excellent image quality.

Ink Compatibility: Dye based/pigmented inks

ITEM NO.	SIZE
KO221615	36" x 100'
KO221616	42" x 100'
KO221617	50" x 100'
KO221618	60" x 100'

PCM-IDBM Indoor Banner Material, 10 mil

This latex and nylon-fiber reinforced paper that is lightweight and water-resistant is durable enough to allow for hemming and grommeting. Excellent for indoor use at trade shows, and for retail displays.

Ink Compatibility: Dye based/pigmented inks

ITEM NO.	SIZE
RMPKIDBM5050	50" x 50'

DMiBOP10 Wet Strength Banner Paper, 11 mil



An economical, latex-saturated nylon-reinforced cellulose, wet-strength indoor banner/outdoor poster and wallcovering material. Resists water and UV damage.

Ink Compatibility: Dye based/pigmented inks

ITEM NO.	SIZE
IIBOP103675	36" x 75'
IIBOP1036125	36" x 125'
IIBOP104275	42" x 75'
IIBOP105075	50" x 75'
IIBOP1050125	50" x 125'
IIBOP105475	54" x 75'
IIBOP106075	60" x 75'

VSF (GFVSF DMVSF) Valeron Strength Film Banner, 12 mil



This strong recyclable material is plasticizer-free, vinyl-free, recyclable, and stronger than most scrim vinyls in the market today. Designed for use with pigmented, solvent and UV Cure inks in durable outdoor banner applications.

Ink Compatibility: Pigmented inks

ITEM NO.	SIZE
IVSF2450	24" x 50'
IVSF3650	36" x 50'
IVSF3675	36" x 75'
IVSF4250	42" x 50'
IVSF5050	50" x 50'
IVSF5450	54" x 50'
IVSF5475	54" x 75'

Rolled prints do not dry completely. Leaving the prints exposed to air is the only way to allow them to fully dry.

When applying grommets to banner materials, remember to use several layers of media for increased durability.



Canvas • Fabric

Cotton/Polyester Blend Canvas

Torino 17M

Stretch Cotton/Poly Blend Canvas, 17 mil



A cotton/polyester blend canvas, acid-free base with a matte finish with long term fade- and water-resistance with pigment inks.

Ink Compatibility: Dye based/pigmented inks

ITEM NO.	SIZE
ITORINO17M2440	24" x 40'
ITORINO17M3640	36" x 40'
ITORINO17M4240	42" x 40'
ITORINO17M4440	44" x 40'
ITORINO17M5040	50" x 40'
ITORINO17M5440	54" x 40'
ITORINO17M6040	60" x 40'

PCM-MAC7



Matte Artist Stretch Canvas, 18 mil

This medium weight cotton/polyester blend canvas offers an excellent white point and images well in a variety of print modes. Offers exceptional water-resistant properties.

Ink Compatibility: Dye based/pigmented inks

ITEM NO.	SIZE
RMPCMMAC74024	24" x 40'
RMPCMMAC74042	42" x 40'
RMPCMMAC74052	52" x 40'
RMPCMMAC74060	60" x 40'

Torino 21G

High-gloss Cotton/Poly Blend Canvas, 21 mil



A canvas for high quality digital output. This canvas provides excellent color gamuts and image stability when printed with pigment- ed inks. Ideal for portraits, fine art reproduc- tions, museum art, heavy-duty indoor sig- nage & photo displays.

Ink Compatibility: Dye based/pigmented inks

ITEM NO.	SIZE
ITORINO21G2440	24" x 40'
ITORINO21G3640	36" x 40'
ITORINO21G4440	44" x 40'
ITORINO21G5040	50" x 40'
ITORINO21G5440	54" x 40'

Matte Canvas



Matte Cotton/Poly Blend Canvas, 19 mil

Offers a subtle texture on a matte finish. It is ideal for high quality, low-glare prints, with a special coating that captures bold colors. Designed for indoor artistic posters and flat wall hangings.

ITEM NO.	SIZE
K08848376	36" x 40'
K01818715	42" x 40'
K08979593	50" x 40'

100% Cotton Canvas

Artists' Semi-Gloss Canvas, 100% Cotton Stretch Canvas, 20 mil



This semi-gloss, heavy-weight, durable tex- tured canvas boasts excellent stretch prop- erties for mounting on a canvas frame. Image longevity and semi-gloss finish provide deep, vibrant color to achieve a beautiful oil paint- ing look.

Ink Compatibility:

ITEM NO.	SIZE
K08559908	36" x 35'
K01074350	42" x 35'
K01031558	50" x 35'

Torino 20M

Matte High Texture 100% Cotton Stretch Canvas, 20 mil



A, highly-textured, pH neutral, artist stretch canvas designed for long-term, fade resis- tant fine art and photographic reproductions when imaged with pigment inks. Has a specifically designed coating which delivers superior color gamut and resolution.

Ink Compatibility: Dye based/pigmented inks

ITEM NO.	SIZE
ITORINO20M2435	24" x 35'
ITORINO20M3635	36" x 35'
ITORINO20M4235	42" x 35'
ITORINO20M5035	50" x 35'
ITORINO20M5435	54" x 35'

Polyester Fabric

FAB-6

Polyester Fabric Banner, 6.8 mil



A 100 % polyester knit woven fabric. This fabric is ideal for producing flags, banners, displays, window decorations, pop-up dis- plays, and window backlits.

Ink Compatibility: Dye based/pigmented inks

ITEM NO.	SIZE
IFAB-624150	24" x 150'
IFAB-636150	36" x 150'
IFAB-642150	42" x 150'
IFAB-650150	50" x 150'



Need help selecting the right product?

The knowledgeable sales team at S&F will be able to assist and advise you in choosing the product that will best fit your application.



Pressure Sensitive/Cold

UC DOL 1060/1080 (DOL 1000/1100)



A 2.1 mil clear, flexible, premium, cast vinyl film designed for use as a protective overlaminate film for screen printed and digital printed decals.

UC DOL 1060 (DOL 1000) Gloss Cast Vinyl Overlaminate, 2.1 mil

Durability: Up to 5 years outdoors

ITEM NO.	SIZE
VADOL10603050	30" x 150'
VADOL10603650	36" x 150'
VADOL10604850	48" x 150'
VADOL106048100	48" x 300'
VADOL10605450	54" x 150'
VADOL106054100	54" x 300'
VADOL10606050	60" x 150'
VADOL106060100	60" x 300'

UC DOL 1080 (DOL 1100) Matte Cast Vinyl Overlaminate, 2.1 mil

Durability: Up to 5 years outdoors

ITEM NO.	SIZE
VADOL10803050	30" x 150'
VADOL10803650	36" x 150'
VADOL10804850	48" x 150'
VADOL10805450	54" x 150'
VADOL108054100	54" x 300'
VADOL10806050	60" x 150'

UC DOL 1360 (DOL 1030)

Gloss Cast Vinyl Overlaminate, 1.3 mil



A premium quality, ultra-thin, ultra-conformable cast, high gloss vinyl film designed for use as a protective overlaminate film for solvent, UV, and screen print inks.

Durability: Up to 4 years outdoors

ITEM NO.	SIZE
VADOL13603050	30" x 150'
VADOL13603650	36" x 150'
VADOL13604850	48" x 150'
VADOL13605450	54" x 150'
VADOL136054100	54" x 300'
VADOL13606050	60" x 150'

UC DOL 1370 *Luster* UC DOL 1380 *Matte*

Cast Overlaminates

SC DOL 1460

Super Conformable Cast Overlaminate, 1.3 mil



DOL 1460 is our most conformable overlaminate available today. No need to worry about complex curves, deep corrugations or grooves. DOL 1460 can handle it all without applying primer, saving you time and money.

- **High gloss finish**
- Provides ultimate conformability for extreme vehicle wrap applications
- Enhances color and depth of image

Durability: Up to 4 years outdoors

ITEM NO.	SIZE
VADOL14602450	24" x 150'
VADOL14604850	48" x 150'
VADOL14605425	54" x 75'
VADOL14605450	54" x 150'
VADOL14606050	60" x 150'

PGM-OLPG



Premium Cast Gloss Overlaminate Film, 2 mil

A high-quality cast vinyl overlaminate film with a permanent adhesive. This product offers excellent UV, chemical and abrasion resistance. The perfect film for all types of indoor or outdoor applications.

Durability: Up to 5 years outdoors

ITEM NO.	SIZE
RMPGMOLPG15036	36" x 150'
RMPGMOLPG15054	54" x 150'

PGM-PMCO



Premium Cast Matte Overlaminate Film, 2 mil

A 2 mil matte cast overlaminate film with a clear adhesive. This cast film is extremely flexible and ideal for vehicle graphics. Matte finishing provides a unique look that reduces reflections and ensures sharp detailed graphics in any lighting condition. Warranted for 60 months by Roland's Wrap Solution Warranty.

Durability: Up to 5 years outdoors

ITEM NO.	SIZE
RMPGMPMCO15054	54" x 150'
RMPGMPMCO15060	60" x 150'



Arctic® UV Cast Film



Provides protection against ultra-violet rays and provides an aggressive adhesive that is ideal for use outdoors. Available with a Gloss or a Sand finish, which are slightly textured and minimizes glare while maintaining vibrant colors.

Arctic® UV Gloss Overlaminate Film, 3 mil

ITEM NO.	SIZE
GBC3247031	38" x 150'
GBC3247030	55" x 150'

Arctic® UV Sand Overlaminate Film, 3 mil

ITEM NO.	SIZE
GBC3247025	38" x 150'
GBC3247026	51" x 150'
GBC3247027	55" x 150'

Arctic® Choice Vinyl



Cast Gloss Overlaminate Film, 2 mil

A high-quality cast vinyl with repositionable aggressive adhesive. Provides a gloss finish and is warranted up to 7 years of outdoor usage. Offers UV resistance. This is an excellent film for long-term outdoor signage and vehicle wraps.

Durability: Up to 7 years outdoors

ITEM NO.	SIZE
GBC3245230	30" x 150'
GBC3245231	54" x 150'

Pressure Sensitive/Cold

Perforated Window Film Overlamine



UC DOL 1560 Optically Clear (DOL 4500)



Perforated Window Film Overlamine, 2.1 mil

An optically clear cast overlaminating film designed to provide a tough, durable solvent and abrasion resistant surface. Designed especially for use with our MPI 4002 Perforated Window Film.

Durability: Up to 1 year outdoors

ITEM NO.	SIZE
VADOL45005450	48" x 150'
VADOL45005450	54" x 150'

DigiLam 631



Conformable Gloss Laminating Film, 2.3 mil

Durability:

ITEM NO.	SIZE
DIGILAM63130150	30" x 150'
DIGILAM63154150	54" x 150'
DIGILAM63160150	60" x 150'

Calendered Overlaminates

DigiLam 600/601/602



A flexible 3.0 mil clear vinyl film with a permanent overlamine adhesive. Designed to protect digital image prints and screen printed images for exhibit and display graphics. Enhances image clarity, contrast and brilliance while offering UV protection.

DigiLam 600 Gloss Laminating Film, 3.0 mil

Durability: Up to 3 years outdoors

ITEM NO.	SIZE
DIGILAM60038150	38" x 150'
DIGILAM60054150	54" x 150'
DIGILAM60054300	54" x 300'

DigiLam 601

Luster Laminating Film, 3.0 mil

Durability: Up to 3 years outdoors

ITEM NO.	SIZE
DIGILAM60138150	38" x 150'
DIGILAM60154150	54" x 150'
DIGILAM60154300	54" x 300'
DIGILAM60161150	61" x 150'

DigiLam 602

Matte Laminating Film, 3.0 mil

Durability: Up to 3 years outdoors

ITEM NO.	SIZE
DIGILAM60238150	38" x 150'
DIGILAM60254150	54" x 150'
DIGILAM60254300	54" x 300'
DIGILAM60261150	61" x 150'

PGM-OLCL



Luster Laminating Film

A high-quality 3 mil luster calendered vinyl overlamine film with a permanent adhesive. This product offers good UV, chemical and abrasion resistance.

Durability: Up to 25 months outdoors

ITEM NO.	SIZE
RMPGMOLCL15030	30" x 150'
RMPGMOLCL15054	54" x 150'

HP DOL 2070/2060/2080



(DOL 2000/DOL 2060/DOL 2080)

A 3.1 mil flexible, clear, luster, gloss & matte calendered vinyl film. DOL 2000 series has been specifically designed as a protective overlamine film for screen or digital printed decals.

Durability: Up to 3 years outdoors

HP DOL 2070 (DOL 2000) Luster Laminating Film, 3.1 mil

ITEM NO.	SIZE
VADOL200030150	30" x 150'
VADOL200038150	38" x 150'
VADOL200044150	44" x 150'
VADOL200048150	48" x 150'
VADOL200051150	51" x 150'
VADOL200054150	54" x 150'
VADOL200060150	60" x 150'

HP DOL 2060 (DOL 2100) Gloss Laminating Film, 3.1 mil

ITEM NO.	SIZE
VADOL210030150	30" x 150'
VADOL210038150	38" x 150'
VADOL210048150	48" x 150'
VADOL210051150	51" x 150'
VADOL21005475	54" x 75'
VADOL210054150	54" x 150'
VADOL210060150	60" x 150'

HP DOL 2080 (DOL 2200) Matte Laminating Film, 3.1 mil

ITEM NO.	SIZE
VADOL220030150	30" x 150'
VADOL220038150	38" x 150'
VADOL220048150	48" x 150'
VADOL220051150	51" x 150'
VADOL220054150	54" x 150'
VADOL220060150	60" x 150'



Pressure Sensitive/Cold

Calendered Overlaminates

Arctic® Series

Available in gloss finish film which adds brilliance to images, in luster finish which limits reflection without loss of sharpness and in matte finish which provides a softer look for your images. Characteristics include both moisture and UV resistance. Excellent film for both indoor and short-term outdoor signage and POP displays.

Durability:

Arctic® Gloss Gloss Laminating Film, 3.0 mil

ITEM NO.	SIZE
GBC9300811	25" x 150'
GBC9300812	31" x 150'
GBC9300813	38" x 150'
GBC9300814	43" x 150'
GBC9300815	51" x 150'
GBC9300816	51" x 300'
GBC9300817	55" x 150'
GBC9300818	61" x 150'
GBC9300819	79" x 150'

Arctic® Lustré Luster Laminating Film, 3.0 mil

ITEM NO.	SIZE
GBC9300821	25" x 150'
GBC9300822	31" x 150'
GBC9300823	38" x 150'
GBC9300846	38" x 300'
GBC9300824	43" x 150'
GBC9300825	51" x 150'
GBC9300826	51" x 300'
GBC9300827	55" x 150'
GBC9300828	55" x 300'
GBC9300829	61" x 150'
GBC9300847	79" x 150'

Arctic® Matte Matte Laminating Film, 3.0 mil

ITEM NO.	SIZE
GBC9300831	31" x 150'
GBC9300832	38" x 150'
GBC9300833	43" x 150'
GBC9300834	51" x 150'
GBC9300835	51" x 300'
GBC9300836	55" x 150'
GBC9300837	55" x 300'
GBC9300838	61" x 150'
GBC9300839	79" x 150'

Polyester Overlaminates

DigiLam 605 High Gloss Laminating Film w/Optical Clear Adhesive, 2.0 mil

A pressure sensitive polyester film with optically clear permanent acrylic adhesive on a 1.5 mil polyester film liner. Designed to protect digital image prints and screen-printed images for exhibit and display graphics. This film can be used to enhance image clarity, contrast, and brilliance.

Durability:

ITEM NO.	SIZE
DIGILAM60538150	38" x 150'
DIGILAM60551150	51" x 150'
DIGILAM60551400	51" x 400'
DIGILAM60554150	54" x 150'
DIGILAM60561150	61" x 150'

Arctic® Photo Gloss High Gloss Laminating Film, 2.0 mil

A gloss finish polyester substrate with an acrylic adhesive and a clear polyester release liner. This high-gloss protective polyester film provides a glossy, color-enriching finish and UV protection for inkjet and photographic prints. Ideal for indoor applications with indirect lighting, as well as short-term outdoor signage.

Durability:

ITEM NO.	SIZE
GBC9300803	38" x 150'

Promotional Calendered

Clear outdoor promotional overlaminate designed for flat surfaces or simple curves. Delivers good abrasion and scratch resistance for short-term graphics, and is offered in a range of finishes.



- Perfect for short-term promotional applications – POP, trade shows, outdoor signage, floor graphics, wall murals and others
- Up to 2-year outdoor durability
- Slip resistant for six months when properly applied

DOL 3060 Gloss Laminating Film, 3.2 mil

ITEM NO.	SIZE
VADOL30603050	30" x 150'
VADOL30605450	54" x 150'
VADOL30606050	60" x 150'

DOL 3070 Luster Laminating Film, 3.2 mil

ITEM NO.	SIZE
VADOL30703050	30" x 150'
VADOL30705450	54" x 150'
VADOL30706050	60" x 150'

DOL 3080 Matte Laminating Film, 3.2 mil

ITEM NO.	SIZE
VADOL30803050	30" x 150'
VADOL30805450	54" x 150'
VADOL30806050	60" x 150'

Scratch Resistant Overlaminates

DigiLam 609 Scratch Resistant Laminating Film, 5.0 mil

A textured vinyl with a 1.5 mil permanent adhesive and a 1.5 mil clear polyester liner. Textured and durable finish while providing UV protection. For use as the overlaminate film to produce mouse pads, counter mats, decal and display overlay.

ITEM NO.	SIZE
DIGILAM60938150	38" x 150'
DIGILAM60954150	54" x 150'



Pressure Sensitive/Cold

Polycarbonate Overlaminates

DigiLam 603

Textured Laminating Film, 5.0 mil

A pressure sensitive 5.0 mil velvet/very fine matte polycarbonate film with permanent acrylic adhesive on a 1.5 mil polyester film liner. Offers protection from abrasion, moisture and other environmental exposures. Designed to protect digital image prints and screenprinted images for exhibit and display graphics.

Durability:

ITEM NO.	SIZE
DIGILAM60338150	38" x 150'
DIGILAM60351150	51" x 150'
DIGILAM60354150	54" x 150'
DIGILAM60361150	61" x 150'



Polycarbonates

Textured Laminating Film

Available in 3mil, 5mil 10mil and 15mil thickness. The velvet finish allows for glare-free viewing. Protects prints from the degrading effects of UV light, thereby extending the life of photographs and digital prints. Compatible with Claritex Printable Polycarbonate Films.

Polycarbonate, 3mil

ITEM NO.	SIZE
DECL3PC38150	38" x 150'
DECL3PC51150	51" x 150'
DECL3PC54150	54" x 150'

Polycarbonate, 5mil

ITEM NO.	SIZE
DECL5PC38150	38" x 150'
DECL5PC51150	51" x 150'
DECL5PC54150	54" x 150'

Polycarbonate, 10mil

ITEM NO.	SIZE
DECL10PC38150	38" x 150'
DECL10PC51150	51" x 150'
DECL10PC54150	54" x 150'

Polycarbonate, 15mil

ITEM NO.	SIZE
DECL15PC38150	38" x 150'
DECL15PC51150	51" x 150'
DECL15PC54150	54" x 150'

Arctic® Polycarbonate



Textured Laminating Film, 5.0 mil

A durable, non-reflective polycarbonate with a velvet textured finish. An excellent choice for trade show graphics, POP displays and other applications where extra durability is needed.

ITEM NO.	SIZE
GBC9300728	38" x 150'
GBC9300730	51" x 150'



Patterned Overlaminates

A brand new way to add dimension and eye appeal to your graphics!

Eclipse Patterned Overlaminates are a family of overlaminate films that feature embossed designs within the surface of the overlaminate. The result is a striking way to add dimension and added appeal to your graphics. Whether you choose the subtle finish of Linen, the rich texture of Carbon Fibre, or any of our other striking finishes, you now have a set of new tools that will not only protect your graphic, but give your design added dimension. For indoor use.

Available in 38", 51 & 54" x 30' or 150'

Following patterns are available:

- Linen
- Glitter
- Frost
- Diamond Plate
- Carbon Fibre



LINEN



CARBON FIBRE

Pressure Sensitive/Cold

Floor Graphics Overlaminates

DigiJet 911

Floor & Carpet Graphics Overlaminates, 6 mil

DigiJet 911 is a clear flexible polished calendared vinyl film designed for use as the protective overlay for floor decals made with DigiJet 910 & DigiJet 912. Adhesive is a permanent acrylic pressure sensitive adhesive formulated for exceptional clarity.

Durability:

ITEM NO.	SIZE
DIGIJET91138150	38" x 150'
DIGIJET91151150	51" x 150'
DIGIJET91154150	54" x 150'



Arctic® Grain



Floor Graphics Overlaminates, 7.4 mil

A highly durable textured vinyl with superior slip, scratch, and dirt resistance. The perfect floor graphic overlaminates. This embossed PVC is very durable and scuff resistant. It is ideal for floor and counter graphics as well as POP applications.

Durability:

ITEM NO.	SIZE
GBC9300862	38" x 150'
GBC9300864	55" x 150"

Arctic® Floor Mat



Floor Graphics Overlaminates, 7 mil

A durable cast vinyl film with a polyester liner that resists scratching. The slip-resistant UL rating makes this film suitable for retail floor graphics. Also works well for counter graphics and other applications requiring long-lasting graphic protection.

Durability:

ITEM NO.	SIZE
GBC3247020	38" x 150'
GBC3247021	51" x 150"

Anti-Graffiti Overlaminates

Arctic® Graffiti



Anti-Graffiti Overlaminates, 1 mil

Made with Tedlar®, an extremely durable polyvinyl fluoride (PVC) film surface for use as an anti-graffiti film. It is washable and resistant to a large number of detergents and solvents. This film provides excellent UV protection. Use for outdoor and indoor applications.

Durability:

ITEM NO.	SIZE
GBC9300883	38" x 150'
GBC9300884	55" x 150"

SF DOL 6060 (DOL 5100)



Anti-Graffiti Overlaminates, 1 mil

A clear polyester over laminating film designed to protect indoor and outdoor markings and decorations against permanent damage from chemical, solvents or graffiti paints. Can be used over digitally printed images to protect the graphic against chemical or mechanical attack.

Durability:

ITEM NO.	SIZE
VADOL51005425	54" x 75'
VADOL51005450	54" x 150'

Dry Erase

DigiLam 611

Dry Erase Film, 2 mil



A clear film coated with a permanent acrylic pressure sensitive adhesive on a smooth paper liner designed for use with dry erase markers. This product is recommended for over laminating graphics, decals and unprinted substrates for use with dry erase pens.

Durability:

ITEM NO.	SIZE
DIGILAM61138150	38" x 150'
DIGILAM61151150	51" x 150'
DIGILAM61154150	54" x 150'

Arctic® Write Erase



Dry Erase Film, 1 mil

A glossy polypropylene film, specifically designed for use with dry erase markers, resists ghosting. Applications include calendars, planners, presentations, litigation graphics, teaching aids, building layouts, and more.

Durability:

ITEM NO.	SIZE
GBC9300898	51" x 150'



See also Dry Erase white printable film on page 16

Finished graphics should be wound face out with a minimum inner diameter of 6 inches.

Keeping the inner diameter at 6" or larger will prevent the graphic from tunneling.



Liquid Laminates

Liquid Laminates

ClearShield®

Waterbase UV-Protective Coating

Clear coatings, also called liquid laminates, are an inexpensive way to protect billboards, prints, fine art, signs, banners,



awnings and other products. Liquid laminates are cost-effective, easy to apply, and do not require extensive equipment.

- Contains State-Of-The-Art UV Inhibitors
- Use On Digital Output: Solvent Based Ink, Electrostatic, Thermal, Pigmented Ink (non water-sensitive)
- Easy Clean-Up With Soap And Water

Standard brush-spray-roll version

ITEM NO.	FINISH	SIZE
CSWBCGQT	Gloss	1 Quart
CSWBCGGL	Gloss	1 Gallon
CSWBCGFG	Gloss	5 Gallon
CSWBCSGQT	Semi-Gloss	1 Quart
CSWBCSGGL	Semi-Gloss	1 Gallon
CSWBCSGFG	Semi-Gloss	5 Gallon
CSWBCSSG20QT	20° Satin	1 Quart
CSWBCSSG20GL	20° Satin	1 Gallon
CSWBQM	Matte	1 Quart
CSWBQGL	Matte	1 Gallon
CSWBQFGL	Matte	5 Gallon

ClearShield Anti-Graffiti Clear

Highly flexible, chemical and uv resistant. Two-component, water-based clear coat easily cleaned with solvent or Clearstar's non-petrochemical citrus based cleaner.

For hand or spray application.

ITEM NO.	FINISH	SIZE
CSWBCGAGQT	Gloss	1 Quart
CSWBCGAGGL	Gloss	1 Gallon

Cross Linking Agent for ClearShield Anti-Graffiti.

ITEM NO.	SIZE
CSWBSCX40Z	4 OZ.

ClearJet®

Solvent Base UV-Protective Coating

Use ClearJet® on most substrates, including canvas, vinyl (enamel



receptive and non-enamel receptive), banners, fiberglass, wood, metal, plastic, and paper. ClearJet® is only for water-based inks: never apply it on solvent-based inks.

- Contains State-of-the-Art UV Inhibitors
- Use on Digital Output: Piezo, Electrostatic, Thermal, Pigmented Ink, Dye-Based and UV Inks
- Excellent for Water-Sensitive Inks, Media, Materials, and Products

Type A2000 - Aerosol Spray

ITEM NO.	FINISH	SIZE
CSSBCJGA2	Gloss	12 OZ.
CSSBCJSGA2	Semi-Gloss	12 OZ.

Type BR - Brush or Roll Version

CSSBCJGBRQT	Gloss	1 Quart
CSSBCJGBRGL	Gloss	1 Gallon
CSSBCJSGBRQT	Semi-Gloss	1 Quart
CSSBCJSGBRGL	Semi-Gloss	1 Gallon

Type AFA - Aerosol Spray FINE ART VERSION

For fine art papers and canvas

CSSBCJGFAA	Gloss	12 OZ.
CSSBCJSGFAA	Semi-Gloss	12 OZ.
CSSBCJLFAA	Low Gloss	12 OZ.



Frog Juice Spray

Frog Juice is very glossy. It is a relative to automotive clear. It is totally synthetic and will not yellow. It does not require a hardener or catalyst.



ITEM NO.	SIZE
LYSFSC	12 oz. spray can.
LYSFCJ	1 Quart

Liquid Laminator

EZ Glide Applicator



Great for protecting wide format prints i.e. outdoor signage (vinyls, scrim banner etc), fine art prints (water resistant canvas), vehicle and boat graphics (vinyls).

- Applies a precise coating that's always smooth and even.
- Saves money by eliminating spray waste and heavy, streaky finishes from hand brushing.
- Costs less than other coaters and faster than motorized coaters.
- Easy to use and easy to clean.
- Available in 38", 55" and 62" widths

ITEM NO.	SIZE
DAI-LL38	38"
DAI-LL55	55"
DAI-LL62	62"

Brown Kraft Paper

Coated with a machine glaze, that is designed to protect the bottom roller from adhesive when doing one-sided lamination.



ITEM NO.	SIZE
DIGIPAPER38450	38" x 450'
DIGIPAPER51450	51" x 450'
DIGIPAPER55450	55" x 450'
DIGIPAPER61450	61" x 450'

Mounting Adhesive

White Mounting Adhesive

DigiMount 501



Opaque White Adhesive

A 1.5 mil white opaque polypropylene film coated both sides with specially formulated permanent acrylic adhesive that is protected with a 76# paper liner. Designed for laminating thin flexible films and papers under 10 mils in total thickness.

ITEM NO.	SIZE
DIGIMA50138150	38" x 150'
DIGIMA50151150	51" x 150'
DIGIMA50151300	51" x 300'
DIGIMA50161150	61" x 150'

Arctic® Cold Mount



This unsupported pressure sensitive mounting adhesive features a moisture-stable, paper release liner. Arctic Cold Mount is ideal for use in pre-coating boards or creating flexible/rollable graphics.

ITEM NO.	SIZE
GBC9300718	51" x 300'

Arctic® White Mount



A pressure-sensitive mounting adhesive that has a white polyester carrier for added opacity. This adhesive brightens and enhances your images and makes an excellent choice for mounting graphics to dark or colored substrates.

ITEM NO.	SIZE
GBC9300903	38" x 150'
GBC9300907	51" x 150'
GBC9300909	55" x 150'
GBC9300911	61" x 150'

Clear Mounting Adhesive

DigiMount 502



Clear Adhesive

Clear Mounting Film is 0.5 mil clear polyester film coated both sides with specially formulated high tack permanent acrylic adhesive that is protected with a 76# paper liner.

ITEM NO.	SIZE
DIGIMA50238150	38" x 150'
DIGIMA50251150	51" x 150'
DIGIMA50251300	51" x 300'
DIGIMA50255150	55" x 150'
DIGIMA50261150	61" x 150'

Arctic® Dura Mount



An economical polyester carrier coated both sides with a permanent pressure sensitive adhesive. This mounting film is a great solution that bonds well to porous, non-plastic surfaces.

ITEM NO.	SIZE
GBC9300853	38" x 150'
GBC9300857	51" x 150'
GBC9300859	55" x 150'
GBC9300869	61" x 150'

Arctic® Premium Mount



A polyester carrier coated both sides with an aggressive, permanent adhesive. It forms a superior bond to a variety of smooth finishes, and is especially designed for applications requiring high initial bond strength.

ITEM NO.	SIZE
GBC3247053	38" x 150'
GBC3247057	51" x 150'
GBC3247061	61" x 150'

Optically Clear Mounting Adhesive

DigiMount 503



Optical Clear Adhesive

Designed to mount backlit transparencies to Plexiglas or other clear substrates in light box applications. Constructed with optically clear polyester that is coated on both sides with an optically clear adhesive and protected by two clear polyester liners. The product also provides images with valuable UV protection.

ITEM NO.	SIZE
DIGIMA50343150	43" x 150'
DIGIMA50355150	55" x 150'
DIGIMA50361150	61" x 150'

Arctic® Vue-Thru



An optically clear, permanent, pressure sensitive adhesive on a polyester carrier used for face-mounting graphics to Plexiglas® and other similar material used in backlit displays and other second surface applications. Works well with SurePrint Translucent Polyester inkjet media.

ITEM NO.	SIZE
GBC3245201	38" x 150'
GBC3245202	51" x 150'

Removable Mounting Adhesive

Arctic® Lo-Tack



A polyester carrier with a removable adhesive for front mounting to glass surfaces. Specially designed channels permit easy application by hand without leaving bubbles. Does not leave a residue when short-term graphics are removed. Ideal for windows graphics and temporary decorations.

ITEM NO.	SIZE
GBC9300888	38" x 150'
GBC9300913	51" x 150'

Arctic® Removable



A white opaque vinyl carrier coated with a removable adhesive on one side and a permanent adhesive on the other. Designed for indoor and short-term outdoor applications where removability is needed, such as floor graphics and wall displays.

ITEM NO.	SIZE
GBC9300866	38" x 150'
GBC9300914	51" x 150'
GBC9300868	55" x 150'



INDEX

DIGITAL MEDIA	5
SIGN VINYL	45
Avery Vinyl.....	46-53
SignGold Vinyl	54-55
Decorative Vinyl	56-57
VINYL AND WRAP SUPPLIES	59
WIDE FORMAT EQUIPMENT	73
VINYL CUTTERS	87
ENGRAVERS	95
SOFTWARE	97
SUBSTRATES	105
BANNER	127
SIGN DISPLAY	139
TAPES & ADHESIVES	145
PAINT	153
NEON SUPPLIES & EQUIPMENT	167
TRANSFORMERS	207
LED SYSTEMS	229
LIGHTING & ELECTRIC	243
SIGN EXTRUSION	267
LETTER & ACCESSORIES	277
MOUNTING HARDWARE	281
EQUIPMENT & SHOP TOOLS	293

Avery Vinyl



S&F is proud to be one of Avery's largest distributors in the United States. Any product, color or size is available for immediate delivery.

All Avery vinyls sold by S&F are guaranteed factory fresh.

Guide to symbols found throughout Avery vinyl color charts on the next few pages

- ▶ 2-year durability
- ▲ 3-year durability
- 4-year durability
- ❖ 5-year durability
- ✖ 6-year durability
- ★ 7-year durability
- ⊕ 8-year durability
- 10-year durability
- Pigmented adhesive - not reversible
- ◆ Removable adhesive
- HT Also available with HiTack adhesive
- LTR Also available with long-term removable permanent adhesive
- BL Blue Liner
- EZ Also available with Easy Apply™ technology
- SF Also available with StaFlat liner
- ☼ Not warranted for use in direct sunlight
- ▼ Can withstand heat up to 200°F
- * Non-adhesive material
- ◆ Also available in THM (non-striped) format
- ❖ Color not used by government institutions and does not have corresponding ASTM or LS300 reflectivity value

PC 500 (A4) Promo Calendered Opaque



Cost-effective, intermediate high-gloss film for signage applications in 30 colors.

Film Type	Calendered vinyl
Adhesive	Permanent
Liner	Kraft
Conformability	Flat
Converting	CAS, screen (SF only), thermal transfer
Durability	Up to 4 years
Gloss	90

Clear PC 500-103-O SF	(A4003-O, SX-3503)	Geranium Red PC 500-435-O	(A4335-O)
White Translit/ ReadyCal PC 500-101-O ◆◆◆ BL SF	(A4001-O)	Merlot PC 500-475-O	(A4375-O)
True White PC 500-105-O ◆ BL	(A4005-O)	Tropical Pink PC 500-512-O	(A4412-O)
Black PC 500-190-O ◆	(A4090-O)	Medium Blue PC 500-655-O	(A4555-O)
Bright Yellow PC 500-208-O	(A4108-O)	Azure Blue PC 500-662-O	(A4562-O)
Stone Yellow PC 500-209-O	(A4109-O)	Flex Blue PC 500-664-O	(A4564-O)
Promise Yellow PC 500-210-O	(A4110-O)	Interstate Blue PC 500-675-O ◆	(A4575-O)
Gold PC 500-215-O ▶	(A4247-O)	Royal Blue PC 500-683-O	(A4583-O)
Canary Yellow PC 500-220-O	(A4120-O)	Mariner Blue PC 500-689-O	(A4589-O)
Apricot PC 500-355-O	(A4155-O)	Dark Navy Blue PC 500-697-O ◆	(A4597-O)
Pizzazz Orange PC 500-359-O	(A4159-O)	Lime PC 500-759-O	(A4659-O)
Autumn Orange PC 500-379-O	(A4179-O)	Cactus Green PC 500-773-O	(A4673-O)
Medium Red PC 500-415-O	(A4317-O)	Mountain Green PC 500-774-O	(A4674-O)
Cherry Red PC 500-420-O	(A4320-O)	Forest Green PC 500-785-O	(A4685-O)
Cardinal Red PC 500-430-O	(A4330-O)	Silver PC 500-801-O ▶	(A4077-O)

Colors shown are ink reproductions and may vary from actual vinyl color. Please refer to Avery's color chart for accurate colors.



HP 700 (A6) High Performance Calendered Opaque

Outstanding cutting and weeding performance in 64 colors. Select colors available with specialized adhesives and liners.

Film Type	Calendered vinyl
Adhesive	Permanent
Liner	Kraft
Conformability	Flat, simple curves
Converting	CAS, screen (SF & EZ only), thermal transfer
Durability	Up to 6 years
Gloss	70



Clear HP 700-103-O ●●	(A6003-O)	Bright Orange HP 700-380-O ◆	(A6180-O)	Olympic Blue HP 700-630-O	(A6530-O)	Sherwood Green HP 700-766-O	(A6666-O)
White HP 700-101-O SF HT EZ BL	(A6001-O)	Tomato Red HP 700-425-O ◆	(A6325-O)	Wedgwood Blue HP 700-632-O	(A6532-O)	Kelly Green HP 700-770-O	(A6670-O)
Matte White HP 700-102-O BL	(A6002-O)	Cardinal Red HP 700-430-O EZ	(A6330-O)	Cool Blue HP 700-633-O	(A6533-O)	Green HP 700-778-O	(A6678-O)
True White HP 700-105-O BL	(A6005-O)	True Red HP 700-432-O	(A6332-O)	Light Blue HP 700-640-O	(A6540-O)	Yellow Green HP 700-780-O	(A6680-O)
Semi-Gloss White HP 700-106-O SF LTR	(MX 3200)	Red HP 700-440-O EZ	(A6340-O)	Cascade Blue HP 700-642-O	(A6542-O)	Forest Green HP 700-785-O	(A6685-O)
Matte Black HP 700-180-O	(A6080-O)	Fire Red HP 700-445-O	(A6345-O)	Medium Blue HP 700-655-O	(A6573-O)	Dark Green HP 700-793-O	(A6693-O)
Black HP 700-190-O HT EZ	(A6090-O)	Dark Red HP 700-450-O	(A6350-O)	Vivid Blue HP 700-670-O	(A6570-O)	Silver HP 700-801-O ▲	(A6077-O)
Semi-Gloss Black HP 700-185-O SF LTR	(MX 3201)	Spectra Red HP 700-460-O	(A6360-O)	Royal Blue HP 700-683-O EZ	(A6583-O)	Slate Gray HP 700-830-O	(A6030-O)
Primrose Yellow HP 700-210-O	(A6110-O)	Burgundy HP 700-470-O	(A6370-O)	Impulse Blue HP 700-687-O	(A6587-O)	Medium Gray HP 700-835-O	(A6035-O)
Gold HP 700-215-O ▲	(A6247-O)	Soft Pink HP 700-508-O	(A6408-O)	Dark Blue HP 700-695-O	(A6595-O)	Dark Gray HP 700-855-O	(A6055-O)
Rubber Duckie HP 700-225-O	(A6125-O)	Blossom HP 700-515-O	(A6415-O)	Dark Navy Blue HP 700-697-O	(A6597-O)	Battleship Gray HP 700-870-O	(A6070-O)
Yellow HP 700-235-O EZ	(A6135-O)	Blush HP 700-519-O	(A6419-O)	Real Teal HP 700-715-O	(A6615-O)	Beige HP 700-920-O	(A6220-O)
Dark Yellow HP 700-250-O	(A6150-O)	Purple HP 700-565-O	(A6465-O)	Teal HP 700-720-O	(A6620-O)	Terra Cotta HP 700-960-O	(A6260-O)
Mustard HP 700-252-O	(A6152-O)	Berry HP 700-570-O	(A6470-O)	Turquoise HP 700-725-O	(A6625-O)	Carmel HP 700-973-O	(A6273-O)
Imitation Gold HP 700-253-O	(A6250-O)	Vibrant Blue HP 700-608-O ●	(A6508-O)	Iguana Green HP 700-758-O	(A6658-O)	Dark Brown HP 700-983-O	(A6283-O)
Tangerine HP 700-315-O ◆	(A6315-O)	Majestic Blue HP 700-625-O	(A6525-O)	Olive Green HP 700-765-O	(A6665-O)	Chocolate Brown HP 700-990-O	(A6290-O)

Colors shown are ink reproductions and may vary from actual vinyl color. Please refer to Avery's color chart for accurate colors.

Avery Vinyl

SC 900 Supercast Opaque (replaces A9)

The new Avery 900 Supercast films boast a variety of enhanced features:

- **Extreme conformability** over deep channels, rivets and compound curves without the need for primer
- Outdoor durability up to 12 years (black and white), 10 years (colors) on vertical applications
- High surface smoothness which brings out a higher gloss
- New 83# kraft liner that assists in more efficient cutting and weeding while maintaining film gloss



Clear UC 900-103-O	(A9003-O)	Apricot UC 900-355-O	(A9155-O)	Pantone Process Magenta C UC 900-511-O	(A9411-O)	Olympic Blue UC 900-630-O	(A9530-O)
Matte Clear UC 900-104-O	(A9004-O)	Orange UC 900-360-O	(A9160-O)	Pantone Violet C UC 900-513-O	(A9413-O)	Nautical Blue UC 900-635-O	(A9635-O)
White UC 900-101-O	(A9001-O)	Pantone Orange 021 C UC 900-362-O	(A9169-O)	Blossom UC 900-515-O	(A9414-O)	Light Blue UC 900-640-O	(A9540-O)
Matte White UC 900-102-O	(A9002-O)	Bright Orange UC 900-380-O	(A9180-O)	Magenta UC 900-530-O	(A9430-O)	Peacock Blue UC 900-645-O	(A9545-O)
True White UC 900-105-O	(A9005-O)	Warm Red UC 900-404-O	(A9304-O)	Raspberry UC 900-535-O	(A9435-O)	Powder Blue UC 900-650-O	(A9550-O)
Cover White UC 900-108-O	(XL 1002, FT 1002)	Pantone 1797 C UC 900-405-O	(A9305-O)	Plum UC 900-540-O	(A9440-O)	Butterfly Blue UC 900-652-O	(A9552-O)
Matte Black UC 900-180-O	(A9080-O)	Pantone Red 032 C UC 900-406-O	(A9306-O)	Deep Purple UC 900-550-O	(A9550-O)	Medium Blue UC 900-655-O	(A9555-O)
Black UC 900-190-O	(A9090-O)	Real Red UC 900-417-O	(A9317-O)	Purple UC 900-565-O	(A9565-O)	Pantone 292 C UC 900-657-O	(A9557-O)
Luminous Yellow UC 900-202-O	(A9102-O)	Luminous Red UC 900-418-O	(A9318-O)	Lavender UC 900-575-O	(A9575-O)	Pantone 293 C UC 900-659-O	(A9559-O)
Butter UC 900-205-O	(A9105-O)	Pantone 485 C UC 900-421-O	(A9321-O)	*Pantone Blue 072 C UC 900-601-O	(A9501-O)	Intense Blue UC 900-665-O	(A9565-O)
Pantone Process Yellow C UC 900-206-O	(A9106-O)	Tomato Red UC 900-425-O	(A9325-O)	*Pantone 277 C UC 900-602-O	(A9502-O)	Vivid Blue UC 900-670-O	(A9570-O)
Pantone 109 C UC 900-216-O	(A9113-O)	Cardinal Red UC 900-430-O	(A9330-O)	*Pantone 279 C UC 900-603-O	(A9503-O)	Interstate Blue UC 900-675-O	(A9575-O)
Canary Yellow UC 900-220-O	(A9120-O)	Fire Red UC 900-445-O	(A9345-O)	Copenhagen UC 900-605-O	(A9505-O)	Pantone 300 C UC 900-678-O	(A9578-O)
Medium Yellow UC 900-230-O	(A9130-O)	Dark Red UC 900-450-O	(A9350-O)	Cadet Blue UC 900-615-O	(A9515-O)	Pantone Reflex Blue C UC 900-679-O	(A9579-O)
Sunflower Yellow UC 900-240-O	(A9140-O)	Spectra Red UC 900-460-O	(A9360-O)	Shadow Blue UC 900-620-O	(A9520-O)	Sapphire Blue UC 900-680-O	(A9580-O)
Dark Yellow UC 900-250-O	(A9150-O)	Apple Red UC 900-465-O	(A9365-O)	Majestic Blue UC 900-625-O	(A9525-O)	Pantone Process Blue C UC 900-682-O	(A9582-O)
Imitation Gold UC 900-253-O	(A9250-O)	Burgundy UC 900-470-O	(A9370-O)	Pantone 285 C UC 900-626-O	(A9526-O)	Light Navy UC 900-690-O	(A9590-O)
Tangerine UC 900-315-O	(A9315-O)	Burgundy Maroon UC 900-480-O	(A9380-O)	Pantone 286 C UC 900-628-O	(A9528-O)	Dark Blue UC 900-695-O	(A9595-O)

*Available by custom order only

Colors shown are ink reproductions and may vary from actual vinyl color.





UC 900 (A9) Ultimate Cast Window Films

Specialty window films that add design impact as cut graphics or overlays.

Film Type	Cast vinyl
Adhesive	Permanent
Liner	Kraft
Conformability	Flat, simple curves
Converting	CAS
Durability	Up to 5 years

Etchmark™ UC 900-861-W	(A5861-S)
Frosted Sparkle UC 900-862-W	(A5862-S)

Film Type	Cast vinyl
Adhesive	Permanent
Liner	Kraft
Conformability	Rivets/corrugations, compound curves
Converting	CAS, screen (SF & EZ Only), thermal transfer
Durability	Up to 10 years (black & white: 12 years)
Gloss	90

Dark Navy Blue UC 900-697-O	(A9597-O)	Grow Green UC 900-772-O	(A9672-O)	Dark Beige UC 900-921-O	(A9230-O)
*Seafoam Green UC 900-703-O	(A9603-O)	Bright Green UC 900-775-O	(A9675-O)	Putty UC 900-935-O	(A9235-O)
Dark Aqua UC 900-705-O	(A9605-O)	Forest Green UC 900-785-O	(A9685-O)	Camel UC 900-940-O	(A9240-O)
Light Sage UC 900-709-O	(A9609-O)	Deep Green UC 900-790-O	(A9690-O)	Pantone 466 C UC 900-952-O	(A9252-O)
Spectra Everglade UC 900-710-O	(A9610-O)	Dark Green UC 900-793-O	(A9693-O)	Terra Cotta UC 900-960-O	(A9260-O)
Real Teal UC 900-715-O	(A9615-O)	Polo Green UC 900-795-O	(A9695-O)	Sandstone UC 900-965-O	(A9265-O)
Teal UC 900-720-O	(A9620-O)	Pewter UC 900-804-O	(A9050-O)	Buckskin UC 900-970-O	(A9270-O)
Pantone 354 C UC 900-726-O	(A9626-O)	Light Gray UC 900-810-O	(A9010-O)	Cocoa UC 900-978-O	(A9278-O)
Dark Teal UC 900-730-O	(A9630-O)	Palm Oyster UC 900-820-O	(A9020-O)	Brown UC 900-995-O	(A9295-O)
Lime Aid UC 900-732-O	(A9632-O)	Light Ash Gray UC 900-825-O	(A9025-O)		
Aquamarine UC 900-733-O	(A9633-O)	Slate Gray UC 900-830-O	(A9030-O)		
Pantone 375 C UC 900-734-O	(A9634-O)	Medium Gray UC 900-860-O	(A9035-O)		
*Spruce Green UC 900-740-O	(A9640-O)	Dark Gray UC 900-855-O	(A9055-O)		
*Dark Ivy UC 900-750-O	(A9650-O)	Med. Marine Gray UC 900-860-O	(A9060-O)		
Vibrant Green UC 900-755-O	(A9655-O)	Pantone 877 C UC 900-869-O	(A9069-O)		
Apple Green UC 900-760-O	(A9660-O)	Parchment UC 900-905-O	(A9205-O)		
Olive Green UC 900-765-O	(A9665-O)	Almond UC 900-910-O	(A9210-O)		
Kelly Green UC 900-770-O	(A9670-O)	Beige UC 900-920-O	(A9220-O)		

Please refer to Avery's color chart for accurate colors.



Avery Vinyl

HV 1100 (A3) High Visibility Reflective



A cost-effective intermediate reflective film in 7 colors for short-term signage.

Film Type	Glass bead retroreflective
Adhesive	Permanent
Liner	Sta-Flat™
Conformability	Flat
Converting	CAS
Durability	Up to 3 years

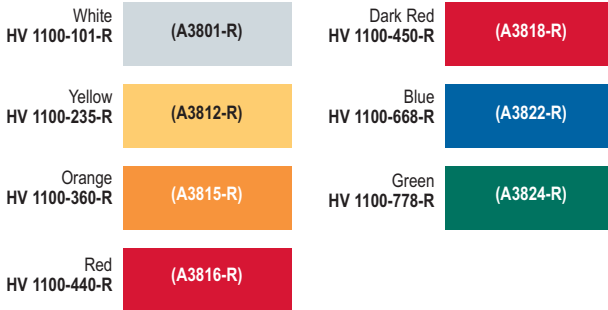

Colors shown are ink reproductions and may vary from actual vinyl color. Please refer to Avery's color chart for accurate colors.

HV 1100 High Visibility Prismatic

High-intensity reflective film, designed for emergency vehicles.

Film Type	Metallized prismatic	White A3911-R	
Adhesive	Removable		
Liner	Clear synthetic		
Conformability	Flat, simple curves		
Converting	CAS, thermal transfer, screen		
Durability	Up to 3 years		

Colors shown are ink reproductions and may vary from actual vinyl color. Please refer to Avery's color chart for accurate colors.

HV 1200 (A7) High Visibility Reflective



The industry's broadest line of high-performance reflective films in 17 colors.

Film Type	Glass bead retroreflective
Adhesive	Permanent
Liner	Sta-Flat™
Conformability	Rivets/corrugations, compound curves
Converting	CAS, screen print, thermal transfer
Durability	Up to 7 years

HV 1200 reflective films now feature the five most popular colors (white, black, red, blue and yellow) with Easy Apply RS™ technology



Colors shown are ink reproductions and may vary from actual vinyl color. Please refer to Avery's color chart for accurate colors.

HV 1200 High Visibility Conspicuity Tape

Highly visible safety markings for school buses and truck trailers.



11" Red/7" White (2" x 150') A7841-S



6" Red/6" White (2" x 150') A7843-S



Yellow (2" x 150') A7844-S

Type	Metallized prismatic
Adhesive	Permanent
Liner	Clear synthetic
Conformability	Flat
Durability	Up to 7 years



Avery Vinyl

PR 800 (A6) Premium Cast Translucent



Cost-effective intermediate translucent vinyl film in 18 colors.

Film Type	Cast vinyl
Adhesive	Permanent
Liner	Kraft
Conformability	Flat, simple curves
Converting	CAS, thermal transfer
Durability	Up to 6 years
Gloss	30

White PR 800-101-T	(A6001-T)
Black PR 800-190-T	(A6090-T)
Primrose Yellow PR 800-210-T	(A6110-T)
Sunflower Yellow PR 800-240-T	(A6140-T)
Pumpkin Orange PR 800-363-T	(A6163-T)
Cardinal Red PR 800-430-T	(A6330-T)
Red PR 800-440-T	(A6340-T)
Wine Red PR 800-471-T	(A6371-T)
Bright Blue PR 800-646-T	(A6567-T)
Sultan Blue PR 800-672-T	(A6572-T)
Ultra Marine Blue PR 800-674-T	(A6574-T)
Royal Blue PR 800-683-T	(A6583-T)
Twilight Blue PR 800-691-T	(A6591-T)
Tidewater PR 800-707-T	(A6607-T)
Green Yellow PR 800-761-T	(A6662-T)
Medium Green PR 800-781-T	(A6781-T)
Bottle Green PR 800-782-T	(A6682-T)
Rust Brown PR 800-980-T	(A6280-T)

UC 900 (A9) Ultimate Cast Translucent



51 translucent colors, including matches of Pantone's most-specified colors for backlit signage. Custom colors available.

White UC 900-101-T	(A9001-T)	Pantone 200 C UC 900-427-T	(A9327-T)	Cobalt Blue UC 900-686-T	(A9586-T)
Pantone Process Black C UC 900-181-T	(A9081-T)	Cardinal Red UC 900-430-T	(A9330-T)	Pantone 281 C UC 900-685-T	(A9588-T)
Pantone 412 C UC 900-198-T	(A9298-T)	Red UC 900-440-T	(A9340-T)	Twilight Blue UC 900-691-T	(A9591-T)
Pantone 012 C A9111-T	(A9111-T)	Poinsettia UC 900-443-T	(A9343-T)	Real Blue UC 900-692-T	(A9592-T)
Pantone 109 C UC 900-216-T	(A9113-T)	Pantone 188 C UC 900-468-T	(A9368-T)	Pantone 2747 C UC 900-693-T	(A9593-T)
Pantone 116 C UC 900-214-T	(A9114-T)	Burgundy UC 900-470-T	(A9370-T)	Pantone 321 C UC 900-619-T	(A9619-T)
Pantone 1235 C UC 900-243-T	(A9143-T)	Pantone 214 C UC 900-516-T	(A9416-T)	Pantone 322 C UC 900-722-T	(A9622-T)
Pantone 1655 C UC 900-361-T	(A9161-T)	Pantone 2622 C UC 900-546-T	(A9446-T)	Pantone 354 C UC 900-726-T	(A9626-T)
Orange UC 900-360-T	(A9180-T)	Pantone 266 C UC 900-560-T	(A9460-T)	Pantone 375 C UC 900-734-T	(A9634-T)
Pantone 7500 C UC 900-218-T	(A9217-T)	Pantone 274 C UC 900-667-T	(A9467-T)	Real Green UC 900-741-T	(A9641-T)
Pantone 872 C UC 900-249-T	(A9249-T)	Pantone 277 C UC 900-602-T	(A9502-T)	Pantone 355 C UC 900-762-T	(A9662-T)
Pantone 155 C UC 900-951-T	(A9251-T)	Pantone 279 C UC 900-603-T	(A9503-T)	Pantone 7483 UC 900-776-T	(A9676-T)
Pantone 466 C UC 900-952-T	(A9252-T)	Pantone 285 C UC 900-626-T	(A9526-T)	Pantone 349 C UC 900-783-T	(A9683-T)
Pantone 4495 C UC 900-275-T	(A9275-T)	Pantone 290 C UC 900-556-T	(A9556-T)	Holly Green UC 900-792-T	(A9692-T)
Pantone 186 C UC 900-408-T	(A9308-T)	Pantone 3005 C UC 900-661-T	(A9561-T)	Pantone 427 C UC 900-811-T	(A9011-T)
Pantone 485 C UC 900-421-T	(A9316-T)	Pantone 2945 C UC 900-661-T	(A9566-T)	Pantone 430 C UC 900-837-T	(A9047-T)
Light Tomato Red UC 900-424-T	(A9324-T)	Pantone 288C UC 900-684-T	(A9584-T)	Pantone 877 C UC 900-869-T	(A9069-T)

Colors shown are ink reproductions and may vary from actual vinyl color. Please refer to Avery's color chart for accurate colors.

UC 900 Light Control Films



White 30% Diffuser UC 900-147-S	(A5847-S)	White Blockout UC 900-151-S	(A5851-S)
White 60% Diffuser UC 900-148-S	(A5848-S)	Black Blockout UC 900-152-S	(A5852-S)

Avery Vinyl

UC 900 Metallic Ultimate Cast Metallics

High-gloss, premium metallic cast film in 29 colors – with vinyl to the edge. Custom colors available.



Film Type	Cast vinyl
Adhesive	Permanent
Liner	Kraft
Conformability	Rivets, compound curves
Converting	CAS, thermal transfer, screen
Durability	Up to 7 years
Gloss	90



White Pearlescent UC 900-101-S	(A5827-S)	Royal Blue UC 900-683-M	(A7749-M)
Black UC 900-190-M	(A7711-M)	Dark Teal UC 900-730-M	(A7767-M)
Champagne Mist UC 900-207-M	(A5720-M)	Hunter Green UC 900-779-M	(A7779-M)
Bright Gold UC 900-213-M	(A3713-M)	Pine Green UC 900-784-M	(A7772-M)
Gold UC 900-215-M	(A3715-M)	Silver UC 900-801-M	(A5701-M)
Light Gold UC 900-217-M	(A3717-M)	Pewter UC 900-804-M	(A7704-M)
Red UC 900-440-M	(A7738-M)	Charcoal UC 900-805-M	(A7705-M)
Autumn Maple UC 900-455-M	(A7740-M)	Gunmetal UC 900-806-M	(A7706-M)
Purple UC 900-565-M	(A7760-M)	Medium Charcoal UC 900-808-M	(A7708-M)
Mist Blue UC 900-641-M	(A7742-M)	Dark Charcoal UC 900-809-M	(A7709-M)
Sea Blue UC 900-644-M	(A7744-M)	Light Briar Brown UC 900-923-M	(A7723-M)
Bright Blue UC 900-646-M	(A7746-M)	Antique Bronze UC 900-928-M	(A5728-M)
Electric Blue UC 900-647-M	(A7747-M)	Bronze UC 900-930-M	(A3730-M)
Grand Blue UC 900-651-M	(A7751-M)	Copper UC 900-932-M	(A5732-M)
Dark Royal Blue UC 900-653-M	(A7753-M)		

Colors shown are ink reproductions and may vary from actual vinyl color. Please refer to Avery's color chart for accurate colors.

UC 900 Ultra Metallic Ultimate Cast Ultra Metallics

Brilliant metallic cast vinyl film in 10 colors – with vinyl to the edge. Custom colors available.



Film Type	Cast vinyl
Adhesive	Permanent
Liner	Kraft
Conformability	Flat, simple curves
Converting	CAS, thermal transfer
Durability	Up to 5 years
Gloss	90

White Sparkle UC 900-160-S	(A3860-S)	Ultra Amethyst UC 900-586-M	(A5786-M)
Ultra Black UC 900-195-M	(A5778-M)	Ultra Blue UC 900-688-M	(A5788-M)
Ultra Gold UC 900-219-M	(A5779-M)	Ultra Cobalt UC 900-694-M	(A5790-M)
Ultra Red UC 900-481-M	(A5781-M)	Ultra Beryl UC 900-791-M	(A5791-M)
Ultra Rosa Quartz UC 900-585-M	(A5785-M)	Ultra Silver UC 900-877-M	(A5777-M)

Colors shown are ink reproductions and may vary from actual vinyl color. Please refer to Avery's color chart for accurate colors.



SF 100 Specialty Films

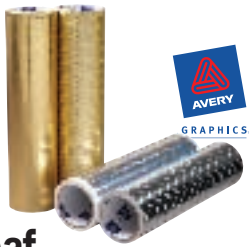

Leaf

- Gold Leaf SF 100-264-S (A5864-S)
- Florentine Gold Leaf SF 100-265-S (A2864-S)
- Hammered Gold Leaf SF 100-271-S (A2871-S)
- Silver Leaf SF 100-863-S (A5863-S)
- Florentine Silver Leaf SF 100-864-S (A2863-S)
- Hammered Silver Leaf SF 100-865-S (A2870-S)

Holographic

- Confetti SF 100-839-S (A0839-S)
- Kaleidoscope SF 100-847-S (A0846-S)

Dry Erase

- Dry Erase Vinyl SF 100-150-S (A0850-S)

Metallized Vinyl

- Black Carbon Weave SF 100-174-S (A2859-S)
- Diamond Plate SF 100-891-S (A2891-S)
- Engine Turn Gold SF 100-259-S (A2859-S)
- Small Engine Turn SF 100-285-S (A2858-S)
- Shimmer SF 100-872-S (A2872-S)
- Silver Illusion SF 100-874-S (A2874-S)
- Silver Carbon Weave SF 100-875-S (A3875-S)

Metallized Polyester

- Brushed Chrome SF 100-840-S (A0829-S)
- Brushed Gold SF 100-242-S (A0830-S)
- Chrome Mirror SF 100-846-S (A0831-S)
- Gold Mirror SF 100-248-S (A0832-S)
- Double Gold SF 100-247-S (A0832-S)

Fluorescent

- Yellow Fluorescent SF 100-229-S (A0829-S)
- Orange Fluorescent SF 100-330-S (A0830-S)
- Red Fluorescent SF 100-431-S (A0831-S)
- Pink Fluorescent SF 100-532-S (A0832-S)
- Blue Fluorescent SF 100-631-S (A0833-S)
- Green Fluorescent SF 100-735-S (A0834-S)
- Magenta Fluorescent SF 100-534-S (A0835-S)

Paint Mask

- White Paint Mask SF 100-128-S (A1828-S, SX 3400)
- Yellow Paint Mask SF 100-230-S (SX 3402)
- High Bake Yellow Paint Mask SF 100-235-S (A1830-S)

True Shadow™

- True Shadow SF 100-803-S (A7840-S)

Printed Film

- Clear Carbon Farber SF 100-132-S (A3832-S)
- Black Carbon Farber SF 100-134-S (A3834-S)
- Bravo Burl SF 100-945-S (A2845-S)
- Cheyenne Teak SF 100-946-S (A2846-S)

Perforated Window Film

- Perforated Window Film SF 100-101-S (A1835-S)

Static Cling

- Static Cling White SF 100-155-S (Sample Provided Upon Request) (A0855-S)
- Static Cling Clear SF 100-158-S (Sample Provided Upon Request) (A0858-S)

Graphic Arts

- Ruby SF 100-462-S (Sample Provided Upon Request) (A0862-S)



We... have more inventory, ship vinyl orders faster, provide better product info, and have more capabilities to support your vinyl projects... than anyone in the industry. Period.



SignGold Vinyl



No other sign making material adds value to signage like gold!

SignGold is used around the world to create beautiful graphics, signage and vehicle lettering, and has given thousands of sign professionals, just like you, the ability to offer "gold leaf" services, without the time and cost of traditional gilding.

SignGold cuts, weeds and applies much like any other high performance vinyl. At only 1 mil thick it not only requires no extra blade pressure when cutting, but will actually conform to rivets and other surface irregularities better than most premium vinyls...and 22 karat gold will not fade!

Fully compatible with other high performance vinyls, your projects become designed of lasting beauty, with SignGold's 10-14 year outdoor life, graffiti, stain and salt water resistance and UV protection.

The 15" comes punched and the 24" Unpunched.

Also available SOLGold inkjet printable 22K gold vinyl.

22K Gold Striping

ITEM NO.	SIZE
Florentine Swirl Striping 50' Rolls	
SG1025XFS	1/4" x 50'
SG1050XFS	1/2" x 50'
SG1100XFS	1" x 50'
Florentine Striping With Black Border	
SGFS5BB	1/2" x 50'
22K Gold Satin Surface Striping 50' Rolls	
SG1025XSS	1/4" x 50'
SG1050XSS	1/2" x 50'
SG1100XSS	1" x 50'
Satin Surface Double Striping 150' Roll	
SG1316YSS	1/16" 150'
SG1516YSS	1/8" 150'
Small Engine Turn Striping 50' Rolls	
SG1SET050	1/2" x 50'
SG1SET100	1" x 50'
Large Engine Turn Striping 50' Rolls	
SG1LET050	1/2" x 50'
SG1LET100	1" x 50'
Large Engine Turn Striping with Black Border	
SG1LET5BB	1/2" x 50'

22K Gold Florentine Swirl

ITEM NO.	SIZE
Florentine Swirl 15"	
SG1FS02	15" x 2 yds.
SG1FS05	15" x 5 yds.
SG1FS10	15" x 10 yds.
Florentine Swirl 24"	
SG1FS42	24" x 2 yds.
SG1FS45	24" x 5 yds.
SG1FS50	24" x 10 yds.
Florentine Swirl 12"	
Thermal Printable for Roland PC12 & PC600	
SGFSP1202	12" x 2 yds.
SGFSP1205	12" x 5 yds.
SGFSP1210	12" x 10 yds.
Florentine Swirl 15"	
Thermal Printable for Gerber Edge	
SG1FSP02	15" x 2 yds.
SG1FSP05	15" x 5 yds.
SG1FSP10	15" x 10 yds.
*Silver Florentine 15"	
SG1SFL02	15" x 2 yds.
SG1SFL05	15" x 5 yds.
SG1SFL10	15" x 10 yds.



22K Gold Satin Surface

ITEM NO.	SIZE
Satin Surface 15"	
SG1SS02	15" x 2 yds.
SG1SS05	15" x 5 yds.
SG1SS10	15" x 10 yds.
Satin Surface 24"	
SG1SS42	24" x 2 yds.
SG1SS45	24" x 5 yds.
SG1SS50	24" x 10 yds.
Satin Surface 15"	
Thermal Printable for Gerber Edge	
SG1SSP02	15" x 2 yds.
SG1SSP05	15" x 5 yds.
SG1SSP10	15" x 10 yds.
*Silver Satin Surface 15"	
SG1SSS02	15" x 2 yds.
SG1SSS05	15" x 5 yds.
SG1SSS10	15" x 10 yds.

22K Gold Surface Matt 15"

ITEM NO.	SIZE
Surface Matt 15"	
Reverse Cut Application	
SGSURFCE22	15" x 2 yds.
SGSURFCE25	15" x 5 yds.
SGSURFCE30	15" x 10 yds.

22K Gold Burnished Glass

ITEM NO.	SIZE
Burnish Glass Gild 15"	
Reverse Cut Application	
SGBRNISH22	15" x 2 yds.
SGBRNISH25	15" x 5 yds.
SGBRNISH30	15" x 10 yds.

*Please note that all genuine silver films must be applied dry and edge sealed. Signgold's Silver Leaf products are not recommended for outdoor use.

SignGold Vinyl

22K Gold Small Engine Turned



ITEM NO.	SIZE
SG1SET02	15" x 2 yds.
SG1SET05	15" x 5 yds.
SG1SET10	15" x 10 yds.

Small Engine Turn 15"

Thermal Printable for Gerber Edge

SG1SETP02	15" x 2 yds.
SG1SETP05	15" x 5 yds.
SG1SETP10	15" x 10 yds.

*Silver Small Engine Turn 15"

SG1SSET02	15" x 2 yds.
SG1SSET05	15" x 5 yds.
SG1SSET10	15" x 10 yds.

22K Gold Large Engine Turned



ITEM NO.	SIZE
SG1LET02	15" x 2 yds.
SG1LET05	15" x 5 yds.
SG1LET10	15" x 10 yds.

Large Engine Turn 24"

SG1LET42	24" x 2 yds.
SG1LET45	24" x 5 yds.
SG1LET50	24" x 10 yds.

Large Engine Turn 12"

Thermal Printable for Roland PC12 & PC600

SGLTP1202	12" x 2 yds.
SGLTP1205	12" x 5 yds.
SGLTP1210	12" x 10 yds.

Large Engine Turn 15"

Thermal Printable for Gerber Edge

SG1LETP02	15" x 2 yds.
SG1LETP05	15" x 5 yds.
SG1LETP10	15" x 10 yds.

*Silver Large Engine Turn 15"

SG1SLET02	15" x 2 yds.
SG1SLET05	15" x 5 yds.
SG1SLET10	15" x 10 yds.

22K Gold XLarge Engine Turned



ITEM NO.	SIZE
SG1XLET02	15" x 2 yds.
SG1XLET05	15" x 5 yds.
SG1XLET10	15" x 10 yds.

Extra Large Engine Turn 24"

SG1XLET42	24" x 2 yds.
SG1XLET45	24" x 5 yds.
SG1XLET50	24" x 10 yds.

Extra Large Engine Turn 15"

Thermal Printable for Gerber Edge

SGXLETP02	15" x 2 yds.
SGXLETP05	15" x 5 yds.
SGXLETP10	15" x 10 yds.

*Silver X Large Engine Turn 15"

SG1SXLT02	15" x 2 yds.
SG1SXLT05	15" x 5 yds.
SG1SXLT10	15" x 10 yds.

SignGold Starter Kits

Includes:

- 2 yards of genuine 22 karat gold vinyl
- "Working With Signgold" instructional CD
- Pricing & Profit guide
- POP retail counter display

Vehicle Graphic Starter Kit

Art schilling's

"Vehicle Graphic" CD-ROM

ITEM NO. SG99VGSP1

For Thermal Printing

ITEM NO. SG19VGT1



Featuring 200 original truck door layouts for nearly 70 common businesses

Sign Design Starter Kit

Brian Briskie's



CD-ROM

ITEM NO. SG99SDSK2

For Thermal Printing

ITEM NO. SG19SDTP2



Featuring instant layouts letting you combine over 200 elements to create over 6,500 designs

"Best Of UK" Starter Kit

Nigel Eyden's

"Best of UK Signwriters" CD-ROM

ITEM NO. SG99UKSK3

For Thermal Printing

ITEM NO. SG19UKTP3



100 designs by one of England's premier sign makers

"Fire Truck" Starter Kit

Art schilling's

"So You Want To Letter A Fire Truck" CD-ROM

ITEM NO. SG99FKK4

For Thermal Printing

ITEM NO. SG19FTTP4



Ready to print and cut fire truck & emergency vehicles graphics

Decorative Vinyl

VinylEfx Decorative Series

All decorative series vinyl are printable with thermal transfer, solvent, eco-solvent, UV screen and digital printers.



Decorative Series VinylEfx offer indefinite indoor life with proper care and handling. The exterior life is 6 to 12 months. The use of a UV protective clear coat of PSA overlaminating film typically extends outdoor durability. Decorative Series is not warranted for exterior applications. Film thickness is 2.8 mil.

AVAILABLE SIZES:

All patterns
24" x 10 yds., 24" x 50 yds.
 Patterns marked with * are also available in the following sizes
48" x 10 yds., 48" x 50 yds



Multi-Lens® Films

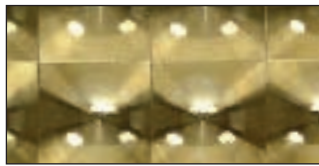

1-3/8" Lens Stock Colors:

- 7301 Silver
- 7302 Gold
- 7303 Cherry Red
- 7304 Royal Blue
- 7314 Black (Galaxy)
- 7312 Raspberry

1/4" Mosaic

- 0201 Silver
- 0204 Royal Blue
- 0202 Gold
- 0211 Orange
- 0203 Cherry Red
- 0217 Fluorescent Green

Metal Flake

- C201 Silver*
- C2004 Royal Blue
- C202 Gold
- C214 Black (Galaxy)
- C203 Cherry Red

Diamond Plate

- K301 Silver*

Brite Overall

- 7901 Silver

Glow-in-The-Dark Film

- 0036 Safe-Glo®

Chrome Colors

- 3101 Silver*
- 3102 Gold*
- 3103 Cherry Red

Carbon Fibre

- WF01 Silver*
- WF14 Galaxy*

Florentine Leaf

- 4402 Gold
- 4401 Silver

Fine Brush

- 6501 Brush Silver*

Decorative Vinyl

VinylEfx Outdoor Durable Series

All Durable series vinyl are printable with thermal transfer, solvent, eco-solvent, UV screen and digital printers.



Outdoor Durable VinylEfx offer up to 5 years exterior life depending on environmental conditions, installation procedures and product suitability to the intended application. Durability may vary. Edge sealing is necessary for applications subject to demanding conditions, such as exposure to drastic weather or climate, marine or winter craft installations, etc. Edge sealing and applying a UV clear coat, or using a PSA UV overlaminating film provides added protection and enhances durability.



AVAILABLE SIZES:

All patterns

15" x 10 yds. (punched), 15" x 50 yds. (punched)

24" x 10 yds., 24" x 50 yds.

Patterns marked with * are also available in the following sizes

48" x 10 yds., 48" x 50 yds



1967 Lg. Engine Turn Gold*



WF01 Carbon Fibre Silver*



6501 Fine Brush Silver*



4402 Florentine Leaf Gold



3101 Smooth Silver*



4101 Sm. Engine Turn Silver*



4167 Sm. Engine Turn Gold*



WF37 Carbon Fibre Black

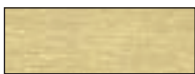

6502 Fine Brush Gold*



J264 Hammered Leaf Gold



3102 Smooth Gold*



K301 Diamond Plate Silver*



Chalkboard Film

with Removable Adhesive, 6 mil

A 6 mil, non-PVC eco friendly chalkboard film, coated with a repositionable, removable adhesive. The grainy textured, slate gray film provides an exceptional finish for

writing or drawing with chalk. Wipes clean with an eraser, damp towel or sponge. Easy application to flat, smooth painted drywall, cabinet doors or refrigerators. Removes easily with no adhesive residue.

Available Sizes:

24" x 10 yds., 24" x 50 yds.

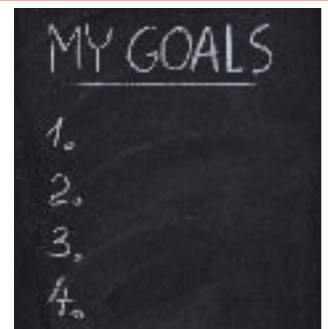



www.sfsupplies.com



INDEX

DIGITAL MEDIA	5
SIGN VINYL	45
VINYL AND WRAP SUPPLIES	59
Application Tape	60-61
Vinyl & Media Racks	62
Application Vehicle Wrap Tools	63-69
Accessories	67
Measuring Devices	71
WIDE FORMAT EQUIPMENT	73
VINYL CUTTERS	87
ENGRAVERS	95
SOFTWARE	97
SUBSTRATES	105
BANNER	127
SIGN DISPLAY	139
TAPES & ADHESIVES	145
PAINT	153
NEON SUPPLIES & EQUIPMENT	167
TRANSFORMERS	207
LED SYSTEMS	229
LIGHTING & ELECTRIC	243
SIGN EXTRUSION	267
LETTER & ACCESSORIES	277
MOUNTING HARDWARE	281
EQUIPMENT & SHOP TOOLS	293

Application Tape

SPECTRUM®

General Purpose High Tack

Spectrum paper application tape takes the hassle and mess out of using transfer tapes. Tears cleanly with no stringy legging adhesive. If adhesive touches adhesive, Spectrum pulls apart easily, with no adhesive transfer. Spectrum also offers superior performance in wet applications, with no gluey mess and no time-consuming clean up.

- Easy to handle
- Forgiving when applying graphics
- Smooth release
- Tears easily with no legging
- No adhesive residue

Roll length is 300'



ITEM NO.	SIZE	ITEM NO.	SIZE
VATSP1	1.25"	VATSP12	12"
VATSP2	2"	VATSP14	14"
VATSP3	3"	VATSP15	15"
VATSP4	4"	VATSP16	16"
VATSP5	5"	VATSP18	18"
VATSP6	6"	VATSP20	20"
VATSP7	7"	VATSP24	24"
VATSP8	8"	VATSP30	30"
VATSP9	9"	VATSP36	36"
VATSP10	10"	VATSP48	48"
VATSP11	11"	VATSP60	60"

The right application tape is like having an extra pair of hands working for you. R-Tape offers many application tapes to fit your specific needs.



Clean-tearing application tapes with lifting power come in a wide range of tack levels to address all types of applications.



No-stretch clear tapes for signmakers come in both embossed and high clarity versions and meet a variety of clear application needs.



Application tapes with **RLA Release Liner Adhesion** are world class performers, available in both paper and film. They make every applicaion easier by laying flat, sticking to slick release liners and resisting tunneling, wrinkling and edge curl.

4075

All Purpose High Tack

High tack application tape for small and medium sized vinyl graphics. This is most popular with signmakers worldwide.

Roll length is 300'

ITEM NO.	SIZE	ITEM NO.	SIZE
VATR1	1"	VATR12	12"
VATR2	2"	VATR14	14"
VATR3	3"	VATR15	15"
VATR4	4"	VATR16	16"
VATR5	5"	VATR18	18"
VATR6	6"	VATR20	20"
VATR7	7"	VATR24	24"
VATR8	8"	VATR30	30"
VATR9	9"	VATR36	36"
VATR10	10"	VATR48	48"
VATR11	11"	VATR60	60"

Also available 4075 RLA with Release Liner Adhesion

AT42-RLA® Clear Conform



Embossed film for bubble free lamination. Film lays flat to liner. For small and medium sized lettering.

Roll length is 300'

ITEM NO.	SIZE	ITEM NO.	SIZE
VATRAT424	4.25"	VATRAT4212	12"
VATRAT426	6.50"	VATRAT4214	14"
VATRAT428	8.50"	VATRAT4215	15"
VATRAT4210	10.50"	VATRAT4218	18"

4000

Low Tack Standard Grade

Designed for the protective masking of wide format digital graphics and large vinyl graphics.

- Protective tape for large wide format digital graphics and large vinyl graphics.

4050

Medium Tack Standard Grade

Medium tack for transfer and premasking of mid-sized die cut or prespaced vinyl and printed graphics.

Also available 4050 RLA with Release Liner Adhesion

AT60 Clear



Matte Finish Clear Film

3.7mil matte rigid finish, medium tack adhesive designed for clean pick up and transfer performance on all brands of cast or calendared vinyl, small and medium sized lettering.

- Exceptional clarity to aid precise registration of multi-color overlays
- Rigid polypropylene film minimizes misalignment problems

Vinyl Application

High Grade High Tack



High Tack. High grade saturated paper backing with superior adhesive technology. Designed for use over ready-to-apply graphics or where large areas of exposed liner are present. This product offers superior adhesion to liner.

Roll length is 300'

ITEM NO.	SIZE	ITEM NO.	SIZE
VATTR592U2	2.25"	VATTR592U15	15"
VATTR592U3	3.25"	VATTR592U16	16"
VATTR592U4	4.25"	VATTR592U18	18"
VATTR592U6	6.5"	VATTR592U24	24"
VATTR592U8	8.5"	VATTR592U30	30"
VATTR592U10	10.5"	VATTR592U36	36"
VATTR592U12	12"	VATTR592U48	48"
VATTR592U14	14"	VATTR592U60	60"

Clear 1310



TransferRite Ultra clear boasts a unique rubber-based adhesive system that provides superior adhesion to liner. The 4 mil polypropylene film offers improved clarity, dimensional stability and an adhesive system that will not haze vinyl.



Roll length is 300'

ITEM NO.	SIZE	ITEM NO.	SIZE
VATTR1310U2	2"	VATTR1310U15	15"
VATTR1310U4	4"	VATTR1310U18	18"
VATTR1310U6	6"	VATTR1310U20	20"
VATTR1310U8	8"	VATTR1310U24	24"
VATTR1310U10	10"	VATTR1310U30	30"
VATTR1310U12	12"	VATTR1310U48	48"
VATTR1310U14	14"	VATTR1310U60	60"

GXP-695



Ultra High Tack Premium Paper Transfer Tape

An ultra high tack paper application tape for vinyl graphics used in sign making and surface protection. The product consists of a self-wound, standard grade Saturated backing coated with a specially formulated latex pressure sensitive adhesive.

ITEM NO.	SIZE
VATGXP69548	48"



PerfectTear Plus™ (GXP 775)

with LFA Lay Flat Adhesive

Perfect for all-purpose sign shop applications. PerfectTear Plus™ paper application tape, lay and stay flat.

- No curling edges.
- Stays flat for easy graphics application.
- Smooth release, even after storing RTAs.
- Tears easily with no legging.
- Sticks to slick silicone release liners.

PreView Plus™



Medium-tack with LFA Lay Flat Adhesive

A static free application film featuring exceptional clarity for easy registration of multiple colors or layers. Utilizing a rigid film stock, PreView Plus™ films lay flat for trouble-free shipping. When it comes to storage of taped vinyl, PreView Plus™ exhibits little or no adhesion growth and the unique surface accepts pen or pencil – allowing for marking lines, registration marks and written notes.

- See-through film allows precise registration
- Static-free for transfer ease
- Minimal errors in applying graphics
- No adhesive residue

PerfectTear (GXP 525)



Low-tack Paper Transfer Tape

A good premask for large vinyl graphics and large-format digital prints.

ITEM NO.	SIZE
VATGXP52548	48"

DigiMask®



Very Low lifting Power

An innovative film designed to protect digital graphics... and is the perfect choice for installing vehicle wraps! Even in hot weather applications, this specially-formulated film stays rigid to prevent stretching, which could result in misaligned graphic panels, yet can be forced to conform around tight fender wells and rivets. When DigiMask® is forced into indentations and around compound curves, it can stretch to more than 1000% elongation!

ITEM NO.	SIZE
DIGIMASK48300	48" x 300'
DIGIMASK54300	54" x 300'
DIGIMASK60300	60" x 300'

DigiMask® Clear



Very Low lifting Power

DigiMask® Clear Surface Protection Film also allows for easy inspection of prints and precise registration of graphic panels during installation. The perfect choice for protecting digitally printed direct to substrate boards.



DigiWrap™



Make installations of digitally printed graphics and screen-printed substrates more manageable with this premier application tape. The premium weight paper prevents scratching and provides excellent stabilization for large-format graphics. Once applied, DigiWrap™ releases easily and cleanly from ink surfaces.

- Extra thick premium paper tape for handling large format graphics
- Superior adhesion to paper for better lay flat (LFA)

Vinyl Application

Vinyl & Media Racks

Free Standing Vinyl Floor Rack

- Strong, bolt together construction
- Holds a total of 44 – 15" and 30" rolls
- Store and organize vinyl, masking tape, transfer tape and packing supplies
- 74"H X 32"W X 18.5"D
- Durable black powder coat finish



ITEM NO. VRAFS

Chrome Plated Floor Stand

- Made of heavy gauge wire
- Holds 72 rolls of 3" core diameter material
- Holds up to 2000 pounds total
- Unit has 9 ball caster rollers



ITEM NO. VRAFS7230

Floor Rack "Chrome Plated"



- Made of heavy gauge and constructed to hold up to 1000 pounds
- Holds 16 rolls of 2" or 3" core diameter material
- Durable enough to hold up to 72 inch wide material with ease
- Rack comes with 16 high impact plastic rings that prevent material damage while storing on the rack.
- Unit has 9 ball caster rollers to allow easy movement with the rack fully loaded

ITEM NO. VRAFR1623

Wall Mount Vinyl Storage Rack

- Double welded loops and bolt together construction
- Holds a total of 16 – 15" & 30" rolls
- Pre drilled mounting holes
- 25.5" x 24.25" W x 15" D
- Durable black powder coat finish

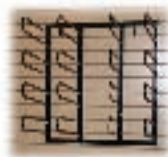

ITEM NO. VRAHD

Short Roll Wall Mount Vinyl Rack

- Light duty wall mount
- Holds a total of 16 – 15" rolls
- 1/4" round rod, welded construction
- Includes four adjustable hangers for mounting to wall
- 27.75" H x 21.75" W x 8" D



ITEM NO. VRA

CA'Roll'Sel Rolling Roll Holder

- 300 lb. capacity
- Holds 7 rolls up to 7" diameter
- Rolls on 7 heavy duty casters
- Models for 2" and 3" cores



ITEM NO.	SIZE
VCRS2BK	for 2" core
VCRS3BK	for 3" core

Roller Tray

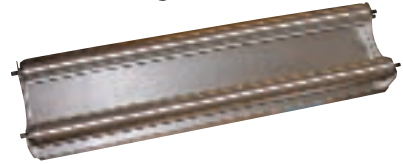

Designed to allow the rolling out of any width material up to fifty (50) lbs. It can also be used as roll feed roller for sprocketed and nonsprocketed drum cutter/plotters.

ITEM NO. VRT

Media Roll Wraps



A safe and affordable way to organize and protect your expensive digital media.

- Keeps your media rolled tight by adjusting to the size of your media rolls.
- Does not leave any adhesive residue.
- Easy to label and keep track of your valuable digital media inventory.



ITEM NO. DIGI-WRAP

Need help selecting the right product?

The knowledgeable sales team at S&F will be able to assist and advise you in choosing the product that will best fit your application.



Vinyl Application

Squeegees

Plastic Squeegee

Regular white squeegee, helps eliminate bubbles.

Size: 4" x 2-3/4"

ITEM NO. VBASQUEEGE



Blue Felt Squeegee

This squeegee with a soft, smooth felt edge protects the vinyl from scratches during application.

ITEM NO. VAZ1058S

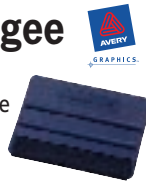

100% Felt Squeegee

ITEM NO. VAZ1059S



3M Nylon Squeegee

These gold colored squeegees made by 3M lasts much longer.

Size: 4" x 2-3/4"

ITEM NO. VSQ4G



Low Friction Felt Sleeve

Provides multiple clean new edge surfaces by simply rotating the sleeve around the Squeegee. Great for digital prints and specialty vinyl.

5 per pack

ITEM NO. VZ0060



Wide Format Squeegee

The industries original, application tool & squeegee. Featuring high-stability twin ribs for easy handling and pressure control.

- Ribbed profile, radial corners
- Poly, Nylon, & Teflon blends
- Designed for wide format graphics

ITEM NO.	SIZE
VSQ60	6"
VSQ120	12"



Felt Edge Wrapped Squeegee

Helps protect vinyl from marring and scratching. Saves time and money by frequently eliminating the need to "wrap" a Squeegee, or using a pre-mask.

- Felt helps protect vinyl
- Terrific for dry applications w/o pre-mask

ITEM NO.	SIZE
VSQ6BL	6"
VSQ12BL	12"

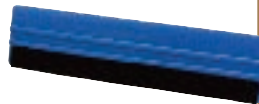

EZ Grip Squeegee Handle

Lightweight yet adds needed rigidity to squeegee edges. Ergonomical design allows for full blade pressure and contact with less wrist strain. Great for wide format squeegees.

Fits 4", 6", and 12" squeegees

ITEM NO.	SIZE
VSQEZG4	4"
VSQEZG6	6"
VSQEZG12	12"



EZ Gripper

Film & Vinyl Installation Tool

E.Z. Gripper Tool™ for film and vinyl installation helps make applications and installations a one-person job. It holds and supports media with its unique design and works like an extra hand for working with wide graphic materials. The E.Z. Gripper Tool™ maintains even tension of the media to reduce potential creases and avoid accidental folding and flopping of media edges.

ITEM NO.	SIZE
VSQEZGT30	30"
VSQEZGT54	54"



WEBER
made

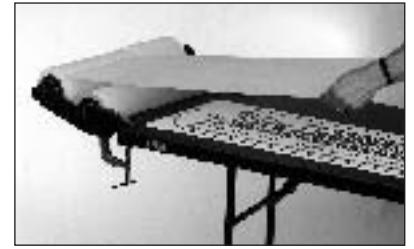

Application Tape Tool

The Quick & Easy Way To Apply Application-Tape To Vinyl - Flawlessly!

- Holds transfer tape straight and steady.
- Single shaft and double shaft models available.
- Guaranteed to save you time and material.
- Each shaft holds one or several tape sizes simultaneously.
- Made to fit standard 3" tape cores.
- 4 sizes to choose from: 16", 24", 36" and 48" width.
- No tools needed to change rolls of tape.
- Lifetime Warranty. All steel construction.

ITEM NO.	DESCRIPTION
VATTS16S	16" Single Shaft
VATTS16D	16" Double Shaft
VATTS24S	24" Single Shaft
VATTS24D	24" Double Shaft
VATTS36S	36" Single Shaft
VATTS36D	36" Double Shaft
VATTS48S	48" Single Shaft
VATTS48D	48" Double Shaft

WEBER
made

12" Stainless Steel Squeegee

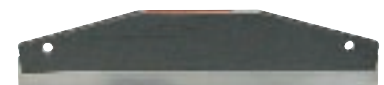

Intended to be used in the shop to apply your application tape to vinyl and is not recommended for use while applying vinyl to a substrate.

ITEM NO. VSQ12SS

Vinyl Application

1-1/2" Rivet Brush

1-1/2" diameter hardwood handle, with short stiff bristles, aids in applying pressure-sensitive materials to rivets and compound curves.



ITEM NO. VZ0015

3" Rivet Brush

3" diameter hardwood handle, with short bristles aids in applying pressure-sensitive materials to large textured areas such as, brick, cement, stucco, banners, etc. Also used when applying graphics to vehicles.



ITEM NO. VZ0016

Power Grip Multi-Pin Air Release Tool MPP-1

This tool helps you save time during installation because the multiple pins require only a single puncture per rivet. The tool has an ergonomically designed grip for added comfort.



ITEM NO. LY3MMPP1

Power Grip Magic Pad Rivet Applicator CMP-1

This applicator can be used to help apply graphic films over rivets.



ITEM NO. LY3MCP1

Aluminum Handle Needle Point Awl 6" x 5/16", 1/32"

Used for making holes in vinyl to allow air trapped in bubbles to escape.

ITEM NO. LYE30604

Installation kit for Textured Surfaces #TS-KIT



This kit contains all the tools you need to effectively and properly apply 3M™ Scotchcal™ Graphic Film for Textured Surfaces IJ8624, including 3M's unique licensed application tools (TSA1, TSA2, TSA3), a high quality heat gun, a heat-resistant glove, several media samples, a comprehensive training DVD and 3M technical literature.



ITEM NO. VACTSKIT

Vehicle Channel Applicator



These hand held tools help conform heated film into channels found on many vehicle bodies and are essential for applying vinyl into the difficult grooves and channels found on Sprinter vans and other vehicles. They also save installers significant time adhering graphics in channels when compared with the traditional squeegee.



ITEM NO.	DESCRIPTION
VACROLLERL	Large
VACROLLERS	Small

3" Vinyl Roller Applicator

This roller is used to easily roll out any bubbles which may exist after vinyl is applied to substrate.

ITEM NO. VZ1006-S



Textured Surface Applicator TSA-1



For large surfaces

This is a tool with a heat-resistant foam roller designed specifically for conforming large areas of selected films to textured surfaces using heat and pressure with the tool.



ITEM NO.	DESCRIPTION
VACTSA1	TSA-1 Applicator
VACTSA1RR	Replacement Roller

Textured Surface Applicator TSA-2



For mortar joints and inside corner

This is a tool with a heat-resistant foam roller designed specifically for conforming selected films to mortar joints and inside corners using heat and pressure with the tool.



ITEM NO.	DESCRIPTION
VACTSA2	TSA-2 Applicator
	Replacement Roller

Textured Surface Applicator TSA-3



For tight spaces

This is a tool with a heat-resistant foam roller designed specifically for conforming selected films around cut edges and into corners using heat and pressure with the tool. It is especially useful with mosaic-type applications.



ITEM NO.	DESCRIPTION
VACTSA3	TSA-3 Applicator
	Replacement Roller

2 Hand Textured Surface Applicator TSA-4



ITEM NO.	DESCRIPTION
VACTSA4	TSA-4 Applicator
VACTSA4RR	Replacement Roller

Vinyl Application

Application Fluid

Action Tac® Application Fluid

Ready to use vinyl application fluid for applying pressure sensitive vinyl and decals to most surfaces.



ITEM NO.	SIZE
VASATQT	Quart
VASATGAL	Gallon

Splash Concentrated Application Fluid

Concentrated Splash is the most cost effective application fluid on the market. Supplied in 8 oz. plastic bottles which dilute to make one gallon of vinyl application solution.



ITEM NO. VASSPL

Decal-Graphic Solution



This 3-in-1 easy-to-use formula: cleans and prepares the surface without leaving any residue ... it then "floats" the vinyl providing ample time to reposition (straighten) graphics ... and it activates the adhesive to create a strong bond between surface and graphic without need for heat gun or lamp.



ITEM NO.	SIZE
VASDGSQT	Quart
VASDGS GAL	Gallon

Spray Bottle

All-purpose plastic bottle with spray cap. Holds one quart.



ITEM NO. LYSB

Window Juice

For applying vinyl lettering, decals and graphics on glass.



ITEM NO.	SIZE
VASWJ4	4 Oz.
VASWJQT	1 Quart

Vinyl Edge Sealer

3M 94 Primer

Tape and adhesives adhesion promoter. Also used to seal vinyl edges.



ITEM NO.	SIZE
LY3MTP943	3 Oz.
LY3MTP948	8 Oz.
LY3MTP94QT	1 Quart

Edge Sealing Compound 902



Liquid, solvent-based sealer protects exposed edges of slip-resistant tapes and treads from excessive moisture or liquids. One 5-ounce tube with convenient tube applicator seals approximately 75 to 100 linear feet. 5 ounce tube.

ITEM NO. LY3MEDGE902

Edge Seal Pen



Seal the edges of your vinyl lettering. Graphics will not curl off even if the lettering is excessively washed and polished.

ITEM NO. SGESP

Rapid Prep

Wax, Silicone and Grease Remover

Safe and super effective "deep cleaning" water base solvent, works in one minute to lift silicone, wax, polymer, grease, nicotine, etc. from the surface.



ITEM NO.	SIZE
VARPRQT	Quart
VARPRGAL	Gallon

Vinyl Remover

Rapid Remover

For removing adhesives quickly without damage or mess. Removes adhesive glue left over by decals and vinyl graphics.



Spray cap included with the 1 quart bottle

ITEM NO.	SIZE
VARRRQT	Quart
VARRRGAL	Gallon

3M Adhesive Remover

Adhesive remover for clean-up of over spray and adhesive build up. Fresh citrus scent.



ITEM NO. VAR604024

Quick 'n Easy Adhesive Remover



Leaves clean surface (no gooey mess) like: mounting tapes, spray tac, ghost lines, art wax, tree sap, tar, oil & adhesives left behind after decals/graphics or vinyl letters are lifted. Safe on glass, vinyl, painted surfaces, plastics.



ITEM NO. VARQEQT

Vinyl-Off Vinyl Remover

A **BREAK THROUGH** product in the Vinyl and Adhesive Removal Field.

Designed to penetrate the vinyl and weaken the adhesive. Removes vinyl graphics from fleet trucks, glass, signage, etc. Just wipe it on, wait a few minutes, and peel off the vinyl-and the adhesive- in one step!



ITEM NO.	SIZE
VARVO8	8 oz. Spray
VARVOQT	Quart
VARVOGAL	Gallon

Vinyl Application

Heat Gun Tool

1220 HS

Dual heat selection – 750 degrees F and 1000 degrees F.

Use for fast, easy, one-step paint removal and dozens of other uses. Includes a hanging hook.

Power: 1200 Watts / 4100 BTUs.

ITEM NO. HDHG1220HS



Industrial 750

Variable heat selection, 500-750 degrees F.

Professional quality heat gun features maximum BTU heat output, high air flow, fast heat transfer, and heavy duty all-metal construction.

Power: 1680 Watts / 5700 BTUs.

ITEM NO. HDHG750



HT1100

Heat Gun Kit

Two temperature settings 750° F. and 1000° F. Contains accessories that are necessary to heat and strip paint from a surface.

Included: Concentrator nozzle, spreader nozzle, glass protector nozzle, a handle with five multi-shaped scraper blades and a rugged storage case.

Power: 1200 Watts / 4100 BTUs.

ITEM NO. HDHGHT1100



HT3500

Digital Heat Gun

Touch-pads activate 12 distinct temperature settings from 250° to 1350° F. enabling the user to match the correct temperature to the application. Two fan speeds for optimum air flow control. Cool-down and automatic shut-off setting.

Power: 1500 Watts / 5100 BTUs.

ITEM NO. HDHGHT3500



Eraser Tool

MBX Vinyl Zapper

A must have for any sign shop. Use this tool with the eraser wheel to quickly remove pin-stripes and decals. You name it, the MBX removes it in seconds. Does not include the eraser wheel.

Available in electric or pneumatic version.

ITEM NO.	DESCRIPTION
MT-ME3200	Electric
MT-MP3500	Pneumatic

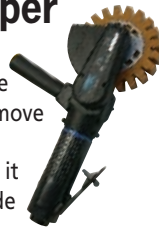

Rubber Eraser Wheel

1.2" wide.

ITEM NO. MT-RE0023



Rotary Cutter



Comfortable ergonomic handle and a dual-action safety lock. Cuts fabrics or paper into shapes, strips and pieces for sewing, quilting and craft projects. 28mm size is great for small scale projects, miniatures, and tight corners. For right- and left-handers.

ITEM NO.	SIZE
LYORTY1DX	28mm
LYORTY2DX	45mm

Replacement Blades

LYORB28-2	28mm
LYORB45-1	45mm

Questions?

Need help selecting the best product? What's the best way to remove a particular vinyl? Our "signology" experts will be happy to provide you with clear, concise answers – just ask!



Chizler Vinyl Removal Tool

One sized polycarbonate tool has proven invaluable for removing materials and applying others in tight corners. Custom rolled edges scrapes without marring.

ITEM NO. VSQCH



Plastic Razor Blades

Double-Edged plastic blade that is strong in design and fits any standard razor holder. Designed to aid in the removal of pressure-sensitive materials on surfaces that are easily scratched. Comes with a blade holder. 25 per pack.

ITEM NO. LYPRB



Metal Safety Glass Scraper

Comes with 5 single edge blades for removing paint, stickers on windows and doors.

ITEM NO. HDGS



Single Edge Blade #9

Replacement blade for HDGS, HDCK
Size: 1-1/2" x 3/4" x 1-1/2" edge. 100 pack

ITEM NO. LYRBB



Lift-Stick

Used to aid in the lifting of pressure sensitive material and the removal of adhesive from surfaces. If used correctly, it will not scratch the substrate. 3/4" x 6".

ITEM NO. VSQLS



Knife & Pick Holder



ITEM NO. VAZ1012S

Vinyl Application

Handle Knife

Olfa AK-4 Precision Art Knife

Anti-slip cushion grip handles. Good For arts, graphics, crafts and hobby.

ITEM NO. LYOAK4

Round Aluminum Handle (K2)

5/16" x 4-3/4" L. Used for precision cutting, trimming and striping of paper, plastic, wood, cloth and film.

ITEM NO. LYE16001

Grip-On Non-Roll Soft Handle Knife

5" x 3/8" features include comfortable soft grip handle.

ITEM NO. LYE77K18

Medium Duty Handle

7/16" x 4-3/4" L. Used for precision cutting, trimming and striping of paper, plastic, wood, cloth and film.

ITEM NO. LYE16002

Replacement Blades

#11 Blade

For Olfa AK-4.

ITEM NO.	DESCRIPTION	PACK
LYOKB4S		5

#11 Blade

For LYAH and LYEK18.

ITEM NO.	DESCRIPTION	PACK
LYE20011	1 1/16" x 1/4" x 1" edge	5
LYE22611	19/16" x 1/4" x 1" edge	100

#16 Blade

For LYAH16.

ITEM NO.	SIZE	PACK
LYE22616	1 1/16" x 1/4" x 5/16" edge	100

#24 Blade

For LYAH16.

ITEM NO.	SIZE	PACK
LYER20024	1 1/16" x 1/4" x 5/16" edge	5
LYER22602	1 1/16" x 1/4" x 5/16" edge	100

Art/Graphics Snap Blade Knife



The ultra-slim design of this stainless steel graphics cutter makes it a popular choice for professional graphic artists and sign-making professionals. Features a slide lock and pocket clip/blade snapper.

ITEM NO. LYOSAC1

Retractable Knife



ITEM NO. VZ1062S

Replacement Blades

Standard-duty, acute angle snap-off replacement blades. 7 cutting edges per blade strip.

ITEM NO. LYOA1160B

Vinyl Cutter



ITEM NO. VAZ1060S

Heavy Duty Snap Blade Knife



Comes with 7 point snap blade used for cutting and trimming.

ITEM NO. LYBAHL

Replacement Blades

Heavy duty replacement blade. 8 cutting edges per blade

Steel Blades

ITEM NO.	PACK
LYOLB10B	10 pack
LYOLB50B	50 pack

Light Duty Snap Blade Knife



Comes with 13 point snap blade for home, office, industrial use, cutting of paper, plastic, wood and other items.

ITEM NO. LYBAH

Olfa 180 Light Duty Snap Blade Knife



Perfect for general home/office use for light-duty cutting jobs. Features a slide lock, pocket clip and built-in blade snapper.

ITEM NO. LYO180

Olfa SVR-1 Stainless Steel Cutter



Perfect for use in moist environments (wall papering, window tinting, etc.) where rust is a concern. Slim design, features a slide lock and pocket clip/blade snapper.

ITEM NO. LYOSVR1

Olfa SVR-2 Auto Lock Stainless Steel Cutter

Features and automatic blade lock for extra control and safety.

ITEM NO. LYOSVR2

Replacement Blades

Standard-duty replacement blade for LYBAH. 13 cutting edges per blade.

Steel Blades

ITEM NO.	PACK
LYAB10B	10 pack
LYAB50B	50 pack

Stainless Steel Blades

LYAB10S	10 pack
LYAB50S	50 pack

Vinyl Application

Tweezers

4-1/2" Curved Point Tweezer



Features include a sharp curved point, fingertip ribs along the holding area and alignment pin for precision and accurate control for hobbyists and professional craftsmen.

ITEM NO. LYE30410

6" Curved Point



Versatile and useful tweezers with curved point, alignment pin and ribbed holding area for reaching and working in normally unreachable areas.

ITEM NO. LYE30415

4-3/4" Sharp Pointed



Tapered shanks for accurate control, for holding and inspecting small objects.

ITEM NO. LYETW

Graffiti Remover Citrus Base



ITEM NO.	SIZE
VARGR4L	4 Liter

Goof Off Graffiti Remover



The quick, easy and proven way to remove graffiti. Specially formulated to cut through spray paint, ink, — powerfully dissolving graffiti without damaging the surface below. Use it on stone, brick, wood, metal, glass, block — and even some factory baked auto finishes.

ITEM NO.	SIZE
TSGRGO	16 oz. spray

Crystal Green Degreaser



ITEM NO.	SIZE
VARGCQT	1 Quart
VARGGAL	1 Gallon

Ghost Off

Ghost-Off restores weather exposed surfaces and easily gets rid of ghost sign images from vehicle surfaces. A ready to use, non-toxic, biodegradable commercial strength solvent. Simply spray onto a dry oxidized surface, wait approximately one minute and then agitate with a soft truck brush. Follow with a rinse from top to bottom with cool water and watch the white oxidation rinse away!



ITEM NO.	SIZE
VARGOQT	1 Quart

WOW! The Ultimate Detailer

AUTO
TECH

- Spray-on & wipe-off dust, fingerprints, smudges, droppings, etc.
- Creates an anti-static, dust & water repellent, final shine on: painted signs, vinyl, plastic, rubber, glass, metal, wood, window tint, etc.
- Won't scratch – safe on all hard surfaces – leaves a smooth, optically clear surface!
- Perfect to touch-up painted & vinyl graphics, signs, office equipment, etc.



ITEM NO.	SIZE
VAPWOWGAL	1 Gallon
VAPWOWPT	1 Pint

Wrap Wash & Polish Kit

The WRAP CARE KIT includes products necessary to safely care for vinyl signage and the other surfaces of the vehicle as well. The kit is a combination of revolutionary CRYSTALTEK products, WRAP WASH and WRAP POLISH as well as micro fiber products to use for washing and polishing the wrapped vehicle. Once a wrap is complete, the installation team signs the external "Thank-you" card and leaves the kit in the front seat of the vehicle.



ITEM NO. VASWK

Wrap Wash

Safe to use on Vinyl-Wrapped Vehicles!! Use for Prep and Maintenance. A super concentrated high foaming and lubricating cleanser. Contains specialized components that produce a positive charge, repelling dirt and leaving a clean mirror-like finish. Will not harm weather seals, wiper blades, or graphics. 1 quart.



ITEM NO. VASWWQT

Wrap Polish

Protects new wraps. Restores original luster to time-dulled finishes, removes light scratches, repairs minor clear coat damage, blocks close to 100% of UV Rays. Wrap Polish does not contain wax. It is a high-tech blend of polymers, which gently removes oxidation and pollution. 8 oz.



ITEM NO. VASWP8

Ultra Glass Cleaner

Far superior to off-the-shelf products, this is a ready to use industrial strength ammonia free glass and mirror cleaner. Formulated to quickly and efficiently remove dirt, grime, road film and bug residue from glass surfaces.



ITEM NO.	SIZE
VARUGCQT	16 oz. spray

Vinyl Application

Tools for Vehicle Wrapping

Super Strong Magnets

Used by vehicle wrappers when preparing and aligning graphics to vehicle. These strong magnets eliminate the use of masking tape. Comes in a set of two.

ITEM NO. VZ1063



Tool Belt

This professionally designed tool-belt by Avery will hold all your tools. Also has a metal plate for magnets.

ITEM NO. VZ1061



PERFe.c.t. Edge Cutting Technology

Used and recommended by leading WRAP & window perf manufactures. This piece can be utilized to edge trim all laminated perforation window films in order to create an optimal seal between the material and glass surface. Distances of the trimmed edge can range from 1/4 - 3/8 of an inch as suggested by manufacturer.

ITEM NO. LYOSVR1-H



TS4000T Welding Torch

Durable, replaceable solid brass tip produces a swirl flame for maximum heat output. Lock button allows finger-free use. Pressure-regulated to burn in all directions. Cast-aluminum body with stainless steel burn tube. This model has adjusting knob for optimal gas consumption and heat output.

ITEM NO. BEN-TS4000T



Disposable Propane Cylinders

For basic use with torches.

ITEM NO.	SIZE
BEN-TX9	14.1 oz.
BEN-TX916	16.4 oz

All Purpose Rags

Strong for tough jobs. Absorbs like a sponge. 200 count.

ITEM NO. VCR



DigiMask® Very Low lifting Power

An innovative clear film designed to protect digital graphics... and is the perfect choice for installing vehicle wraps! Even in hot weather applications, this specially-formulated film stays rigid to prevent stretching, which could result in misaligned graphic panels, yet can be forced to conform around tight fender wells and rivets. When DigiMask® is forced into indentations and around compound curves, it can stretch to more than 1000% elongation!

ITEM NO.	SIZE
DIGIMASK48300	48" x 300'
DIGIMASK54300	54" x 300'
DIGIMASK60300	60" x 300'

DigiMask® Clear Very Low lifting Power

DigiMask® Clear Surface Protection Film also allows for easy inspection of prints and precise registration of graphic panels during installation.



Accessories

Paper

White Sign Writer Poster Paper, 20 Lbs.



This high quality extra white paper provides an improved image when plotting with felt pens. Because of the high density of this paper, punching holes are much more uniform and provides improved durability in pin registration.

ITEM NO.	SIZE	ITEM NO.	SIZE
PA2012	12 x 150'	PA2036	36 x 150'
PA2018	18 x 150'	PA2042	42 x 150'
PA2024	24 x 150'	PA2048	48 x 150'
PA2030	30 x 150'	PA2060	60 x 150'

Punched White Paper



ITEM NO.	DESCRIPTION
LYCP2015500	20# 15" x 500'
LYCP2030300	20# 30" x 300'
LYCP2030300H	20# 30" x 300' 1/2" PUNCH
LYCP8015500	80# 15" x 500'

Brown Kraft Paper #70 lb.



ITEM NO.	SIZE
LYPBC24	24"
LYPBC36	36"
LYPBC48	48"
LYPBC52	52"
LYPBC60	60"

SF Brown Kraft Paper #50 lb.

ITEM NO.	SIZE
LYBKP5550	55" x 500'

Tracing Paper, 30 lb.

Medium weight #51. Exceptionally clear, tops in transparency. Resists curling and wrinkling.

ITEM NO.	SIZE	ITEM NO.	SIZE
LYTP12	12 x 150'	LYTP36	36 x 150'
LYTP18	18 x 150'	LYTP42	42 x 150'
LYTP24	24 x 150'	LYTP48	48 x 150'

Tape

Scotch-Blue™ Painters Masking Tape #2090



This tape removes cleanly without adhesive transfer or surface damage for up to 14 days, even in direct sunlight. It is a medium adhesion tape that is ideal for painted walls and trim, woodwork, glass and metal.

ITEM NO.	SIZE
LY3M209034	3/4" x 60 yds.
LY3M20901	1" x 60 yds.
LY3M20902	2" x 60 yds.

Masking Tape



ITEM NO.	SIZE
LYMT3/4	3/4"
LYMT1	1"
LYMT1-1/2	1 1/2"
LYMT2	2"
LYMT3	3"

Lettering Tape

3/8"x180 yards Available in Clear and Red



ITEM NO.	DESCRIPTION
LYT38CL	Clear, 3/8"x180yds
LYT38R	Red, 3/8"x180yds

Pounce Wheel



ITEM NO.	SIZE
LYE30606	1/4"
LYE30607	7/16"

Marking

Black Charcoal



ITEM NO.	SIZE
LYCC	#8
LYCC9	Jumbo #9

Stabilo Pencils



The STABILO All can do just about everything. And not just on paper. Also writes on glass, plastic & metal.

ITEM NO.	COLOR
LYSB8008	#8008 Graphite
LYSB8040	#8040 Red
LYSB8041	#8041 Blue
LYSB8044	#8044 Yellow
LYSB8045	#8045 Brown
LYSB8046	#8046 Black
LYSB8052	#8052 White
LYSB8054	#8054 Orange

China Marker



ITEM NO.	COLOR
LYCMBK	Black
LYCMBL	Dark Blue
LYCMR	Red
LYCMW	White

Pilot Markers SC-6600

ITEM NO.	COLOR
LYPSC6600	Black
LYPSC6600BL	Blue
LYPSC6600G	Green

Refill Ink

LYPSCRFBK	Black
LYPSCRFBL	Blue
LYPSCRFR	Red

Measuring Devices

Straight Edge Ruler



Extruded aluminum with clear (silver) anodized finish. Screened, thermal-bonded black graduations in 1/8ths and 1/16ths.

ITEM NO.	SIZE	ITEM NO.	SIZE
HDMDRS18	18"	HDMDRS60	60"
HDMDRS24	24"	HDMDRS72	72"
HDMDRS36	36"	HDMDRS96	96"
HDMDRS48	48"		

Light Weight Safety Ruller

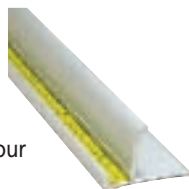

Safety ruler has a curved guard that will protect your fingers when cutting.

Measurements in inches and centimeters.

ITEM NO.	SIZE
HDMDREC39	39.5"
HDMDREC59	59"
HDMDREC98	98.5"

Pro Steel Safety Rulers



The aluminum safety ruler has a curved guard that will protect your fingers when cutting. Also has a non-slip rubber gipper material on back that locks the ruler down.

ITEM NO.	SIZE
HDMDRPS28	28"
HDMDRPS40	40"
HDMDRPS52	52"
HDMDRPS64	64"
HDMDRPS76	76"
HDMDRPS100	100"

Steel Edge Rhino Ruler



ITEM NO.	SIZE
HDMDRRS28	28"
HDMDRRS40	40"
HDMDRRS52	52"
HDMDRRS64	64"
HDMDRRS76	76"
HDMDRRS100	100"

L Square



ITEM NO.	SIZE
HDMDLS812	8" x 12" (#430)
HDMDLS1624	16" x 24" (#CS1)

T Square



Aluminum T-Squares are made of high quality "tempered" extruded aluminum which will not rust. The tongue is securely attached to the blade using four (4) stainless steel rivets to assure accurate 90 degree angles. Easy to read numbers and graduations.,

ITEM NO.	SIZE
HDMDTS24	24"
HDMDTS36	36"

Heavy Duty T Square

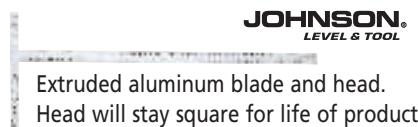

Extruded aluminum blade and head. Head will stay square for life of product.

ITEM NO.	SIZE	BLADE THICKNESS
HDMDTS48	48"	1/8"
HDMDTSH48	48"	3/16"
HDMDTSH54	54"	3/16"

Adjust-A-Square



Extruded aluminum 1/4" thick blade and head. Adjusts to any angle. Precision machined head and blade lock together for a perfect 90° angle.

ITEM NO.	SIZE
HDMDAS48	48"
HDMDAS54	54"

Nylon Coated Tape Measures

- Bright yellow with black rubber casing
- 1/8" Markings for accurate readings
- Easy to Read Fractions
- Belt hook



ITEM NO.	SIZE
HDMDTM34	3/4" x 16'
HDMDTM12	1" x 25'

Magnetic Tip Power Tape Measure 30'

JOHNSON.
LEVEL & TOOL



- Easy Reading Large Numbers on 1-1/16" Wide Blade
- Blade-Gard™ Nylon Coated Blade Resists Abrasion
- Double Duty 2-Sided Printed Blade
- Strong Holding Rare Earth Magnetic Tip Holds to Ferrous Metal Surfaces
- Impact Resistant Ergonomic Co-Molded Rubberized Case



ITEM NO. HDMDTM130

JOHNSON.
LEVEL & TOOL

24" Structo-Cast® Level



Structo-Cast® frame will not scratch fine wood or painted surfaces. Durable acrylic vials are impact resistant. Quik-Change® replaceable vial covers

ITEM NO. HDMDL24

JOHNSON.
LEVEL & TOOL

Mini Laser Level



ITEM NO. HDMDLML



www.sfsupplies.com



INDEX

DIGITAL MEDIA	5
SIGN VINYL	45
VINYL AND WRAP SUPPLIES	59
WIDE FORMAT EQUIPMENT	73
Eco-Solvent Printers.....	74-77
Solvent Printers	78
UV Printers	79
Inks.....	80-82
Laminators.....	83-85
Cutters & Trimmers	85-86
VINYL CUTTERS	87
ENGRAVERS	95
SOFTWARE	97
SUBSTRATES	105
BANNER	127
SIGN DISPLAY	139
TAPES & ADHESIVES	145
PAINT	153
NEON SUPPLIES & EQUIPMENT	167
TRANSFORMERS	207
LED SYSTEMS	229
LIGHTING & ELECTRIC	243
SIGN EXTRUSION	267
LETTER & ACCESSORIES	277
MOUNTING HARDWARE	281
EQUIPMENT & SHOP TOOLS	293

Eco-Solvent Printer/Cutters



- Print and Cut in one unit
- Prints on uncoated and coated media
- Up to 3 years outdoor durability without lamination
- Uses ECO-SOL MAX Ink - odorless and user-friendly with costs as low as 16¢ per sq. ft.
- Photorealistic printing up to 1440 dpi.
- All Roland printers come with Versaworks RIP software.

VersaCAMM® SP-300i & SP-540i



30" & 54" Print & Cut

VersaCAMM® SP-i is the perfect high-performance production tool for creating colorful decals, labels, banners, posters, vehicle and floor graphics, apparel decoration and just about any sign imaginable.

The VersaCAMM SP-i series is the industry's most versatile entry-level device, combining 4-color printing and contour cutting all in one device through one seamless workflow.

- 30" and 54" wide-format inkjet printer/cutters
- Roland Intelligent Pass Control for outstanding print quality and increased productivity
- ECO SOL MAX eco-solvent ink
- 1440 x 720 dpi resolution
- Heavy duty media handling system supports heavier rolls
SP-300i – up to 44 lbs.
SP-540i – up to 66 lbs.
- Integrated heater system
- Ethernet connectivity
- Automated maintenance system with redesigned maintenance cover
- Optional take up system



Call for Price!

SP-300i LIST ~~\$12,495~~
SP-540i LIST ~~\$17,895~~

VersaCAMM® VS-420, VS-540 & VS-640



42", 54" & 64" Print & Cut

With the industry's most advanced print head technology, integrated print/cut capabilities, superior media handling and print speeds up to 248.6 sqft./hr. in dual CMYK mode (64" model), the VS series is our fastest, most versatile VersaCAMM wide-format inkjet printer/cutters ever. Metallic and white inks add impact to any graphic for attention-grabbing results that elevate your brand message.

Available in 64", 54" or 42" models, VersaCAMM VS printer/cutters achieve stunning results across a world of applications including signs, banners, vehicle graphics and wraps, fine art posters, packaging prototypes, labels, decals, POP displays and apparel heat transfers.

- Offered in three ink configurations:
 - 4-colors KYMCCMYK for the highest print speeds
 - 6-colors CCMYK + Lc+Lm for enhanced blues and reds, flawless flesh tones and improved image quality across lighter colors
 - 8-colors CMYK+ Lc+Lm+Mt+W for white and metallic applications
- Metallic Silver ECO-SOL MAX Ink
 - Prints as a spot color
 - Combines with CMYK for stunning metallic colors



Call for Price!

VS-420 LIST ~~\$18,995~~
VS-540 LIST ~~\$22,995~~
VS-640 LIST ~~\$26,495~~



All blades, blade holders and Cutter blades on page 89



Eco-Solvent Printer/Cutters

SOLJET PRO III XC-540



54" Print & Cut

Industry's Most Advanced Printer/Cutter

The ultimate high-volume production tool for stunning indoor and outdoor banners, signs, vehicles, decals, POP displays and more. Featuring Roland's proprietary Intelligent Pass Control™ technology for unmatched productivity and flawless print quality in every print mode. The XC-540 delivers rich, dense 6-color CMYK+Lm images at an impressive maximum print speed of 441 sqft./hr. For maximum productivity, the XC-540 features a tri-heating system and advanced media feed and automatic take-up system.



The XC-540 can also be configured as a 5-color model equipped with White ECO-SOL MAX ink, creating bold white graphics for packaging comps, window graphics, POP, labels, decals and more.

- Uses ECO-SOL MAX Ink - odorless and user-friendly
- Blazing print speed – up to 441 sqft./hr.
- Photorealistic printing up to 1440x1440 dpi
- Two-Year Trouble-Free Warranty
- Optional DU-540 dryer/blower unit



Call for Price!

XC-540
LIST ~~\$31,495~~

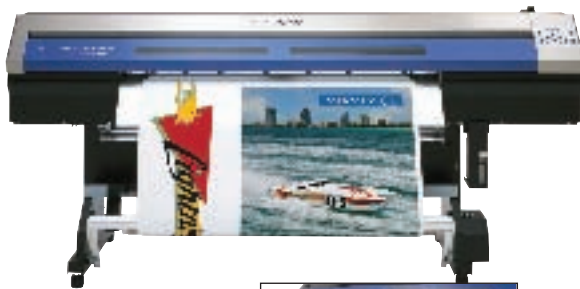

Optional Accessories



Dryer & Blower System

ITEM NO.	DESCRIPTION
DU-540	for XC 540

SOLJET PRO III XC-540MT



54" Print & Cut, w/Metallic Silver Ink

The XC-540MT features six colors, CMYK+Metallic Silver+White (CMYK+Mt+W). Compatible with vinyl, PET film, canvas, paper, transparent film and banner substrates, the new metallic silver ink can be printed as a spot color or combined with the XC-540MT's CMYK inks to produce a range of colored metallic effects including gold, silver, bronze and other pearlescent colors.

With the XC-540MT, professionals can produce signs, banners, labels, POP displays, vehicle graphics and all types of wraps, taking advantage of a whole new metallic color palette. A double white ink model (CMYK+WW) is also available for the brightest white text, graphics and floods.

• Choose from two ink configurations:

- CMYK+ Mt+W
- CMYK+WW

• Metallic Silver ECO-SOL MAX Ink

- Prints as a spot color
- Combines with CMYK for stunning metallic colors

• Print speed of 441 sqft./hr. in CMYK mode

• Photorealistic printing up to 1440x1440 dpi

• Automated take-up system included

• DU-540 dryer system included



Call for Price!

XC-540MT
LIST ~~\$39,995~~



Expert Technical Support

Need help selecting the best product to meet your sign, display or banner design? Not sure which printer model to buy? Wondering about warranties and specs? What's the best media, vinyl, etc. for your application? Our "signology" experts will be happy to provide you with clear, concise answers – just ask!



Eco-Solvent Printers



VersaArt RS Series RS-540 & RS-640



The VersaArt RS series of eco-solvent wide-format printers integrates the latest technologies from Roland's award-winning VersaCAMM and SOLJET PRO III models. Offered in 54" and 64" 4-color (CMYK) models, the VersaArt is the perfect production tool for both indoor and outdoor graphics including signs, POP/POS materials, banners, posters, vehicle graphics and wraps. It also supports soft signage and fabric applications.

VersaArt prints reflect the highest image quality thanks to Roland Intelligent Pass Control™ technology, a unique three-dimensional ink firing system that precisely controls droplet size and placement for exceptionally smooth results every time.

Call for Price!

- Eco-solvent inkjet printers offered in 54" & 64" models
- Roland Intelligent Pass Control technology eliminates banding in virtually every print mode
- Maximum print speeds: 230 sqft/hr for the RS-640, 221.7 sqft/hr for the RS-540
- Outstanding image quality up to 1440 x 720 dpi
- Optional automated take-up system

RS-540 54"
LIST ~~\$16,295~~

RS-640 64"
LIST ~~\$17,895~~



Pure Print Performance!

SOLJET PRO III XJ Series XJ-540, XJ-640 & XJ-740



The SOLJET PRO III XJ series of wide-format inkjet printers combines high-speed performance and superior image quality for the ultimate in six-color digital printing. The industry's most advanced wide-format printers and the ideal production tools for stunning outdoor banners, signs, vehicle graphics and more. Advanced media feed and automatic take-up system support the demands of high-volume shops.

- High-performance eco-solvent printers in 54", 64" and 74" models
- 1440x1440 dpi for photorealistic CMYK+LcLm graphics
- Print speeds of up to 459 sqft./hr. for the 74" XJ-740, 449.5 sqft./hr. for the 64" XJ-640 and 441 sqft./hr. for the 54" XJ-540
- Optional DU-540, DU-640 and DU-740 dryer system

Optional Accessories

Dryer & Blower System

ITEM NO.	DESCRIPTION
DU-540	for XJ 540
DU-640	for XJ 640
DU-740	for XJ 740

Call for Price!

XJ-540 54"
LIST ~~\$26,295~~

XJ-640 64"
LIST ~~\$29,395~~

XJ-740 74"
LIST ~~\$31,495~~



Grand Format Printer

SOLJET™ Pro II V SJ-1045



The SOLJET™ SJ-1045 grand format printer is Roland's widest inkjet ever. At 104 inches wide, it prints billboards, banners and vehicle graphics up to 484 sqft./hr. Like the rest of the SOLJET™ Series, the SJ-1045 prints brilliant graphics directly onto uncoated materials without harmful fumes or expensive ventilation systems.

- Accepts media up to 104 inches wide
- Prints up to 484 sqft.
- IS-1000 high capacity ink delivery system holds 24 ink cartridges
- Two ink configuration options: CCMYK & CMYK LcLm

SJ-1045 104"
LIST ~~\$59,995~~

Call for Price!



Eco-Solvent Printer Supplies

Roland Printer Accessories

Cleaning Fluid

For Eco-Solvent Printers



ITEM NO.	SIZE
CDRSPUSCLNFLDSJ	4 oz.
CDRSP21755107	500ml

Cleaning Cartridge

For Eco-Solvent Printers



ITEM NO.	PACK
RMISL-CL	1 Cartridge
CDRSPSLCLSET	3 Cartridges
CDRSPSLCLSET4	4 Cartridges

Cleaning Sticks

50 pack

ITEM NO. CDRSPIJSWABKIT5



Wiper Head

For all Printers

ITEM NO. CDRSP1000003390



Wiper Scraper

For all Printers

ITEM NO. CDRSP1000001658



Cap Top

For all Printers

ITEM NO. CDRSP1000002794



Syringe Kit

Includes:

- 6 Syringe Tubes
- 2 Tubing (12 inches)
- 4 Fitting 3/32 Barb
- 1 Tubing (4 inches)



ITEM NO. CDRSPUS-SYR-KIT

Media Clamps

For SC Printers

ITEM NO. CDRSP-21765122



Slider

ITEM NO. CDRSP-22185128

Filter Serge Mist

For SP-300/SP-540

ITEM NO. CDRSP1000000416



For VP, XC & XJ Printers

ITEM NO. CDRSP1000000415

Serge Mist (T Sponge)

For SP Series

ITEM NO. CDRSP22275120

For XJ & SJ Series

ITEM NO. CDRSP22275122



Damper

For SP & SJ Series

ITEM NO. CDRSP6081181200

For VP, XC & XJ Series

ITEM NO. CDRSP6085393800



Blade Holder & Blade

See Page 89



Media Flanges

New & Improved!

ITEM NO. CDRSP1000003083



Stoppers

For XC and VersaCamm Series

Stopper

ITEM NO. CDRSP1000001579

Stopper Screw

ITEM NO. CDRSP7498805000

Stopper Nut

ITEM NO. CDRSP3000000036



Cutter Protection Strip

ITEM NO.	DESCRIPTION
CDRXDCPS300	for SP-300
CDRXDCPS50	for SP-540
CDRXDCPS500	for CJ-500, SC-500
CDRXDCPS540	for CJ,SC-540, SC-545

Bolt/Nut Pen Holder

Bolt

ITEM NO. CDRSP-21815101

Nut

ITEM NO. CDRSP-22285503

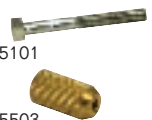

Material Saver Floor Rack

Economical alternative to take-up!

Protect your inkjet, cut vinyl or film materials from attracting dirt or dust particles from the floor. A single rack will catch material up to 48" wide. For wider material use multiple racks.

ITEM NO. VRAMS

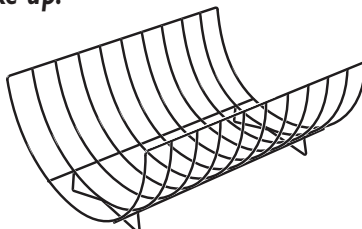

Need help selecting the right product?

The knowledgeable sales team at S&F will be able to assist and advise you in choosing the product that will best fit your application.



Solvent Printers

Grand Format Printer

AdvancedJET AJ-740i & AJ-1000i



With a maximum print speed of 968 for the 104" AJ-1000 and 872 sqft./hr. for the 74" AJ-740, the AdvancedJET AJ series has redefined the standards for high-volume production printing. The AJ series is ideal for high-volume applications including banners, billboards, outdoor signage and other durable graphics, producing brilliant six-color CMYK+LcLm graphics on both coated and uncoated media. AJ graphics reflect superior ink bonding, and scratch and alcohol resistance for outstanding outdoor durability. An automated maintenance system ensures reliable performance and eliminates the need for daily manual cleanings. The AJ also features an optional Mesh Printing Unit supporting lightweight, unlined mesh media.

- Industrial high-speed inkjet printers in 74" and 104" models
- Print speeds of up to 968 sqft./hr. (104" AJ-1000) and 871 sqft./hr. (74" AJ-740)
- Superior image quality at 484 sqft./hr. (AJ-1000) and 473 sqft./hr. (AJ-740)
- Precision graphics of up to 720x720 dpi resolution
- Durable Eco-Xtreme ink creates brilliant outdoor banners and vehicle graphics
- Great print quality on a variety of media including unlined mesh
- Optional Mesh Printing Unit available
- Heavy-duty media feed and take-up system supports 220 lb. rolls
- High-capacity ink delivery system features 1 liter cartridges
- Automated maintenance system ensures reliable performance and easy operation
- Roland VersaWorks RIP software included
- Integrated tri-heater and blower print-drying system comes standard



AJ-740 74"

LIST ~~\$54,995~~

AJ-1000 104"

LIST ~~\$69,995~~

Eco Xtreme Ink 1000ml

for AJ Series

- Developed for industrial-strength performance
- Comes in 6 vivid colors (CMYK+LcLm)
- Performs across a wide range of coated and uncoated media



ITEM NO.	COLOR
RMIAI-BK	Black
RMIAI-CY	Cyan
RMIAI-MG	Magenta
RMIAI-YE	Yellow
RMIAI-LC	Light Cyan
RMIAI-LM	Light Magenta

Call for
Price!

Optional Accessories

ITEM NO.	DESCRIPTION
MU-740	Mesh Unit Option for AJ-740
MU-1000	Mesh Unit Option for AJ-1000
AI-ML	Maintenance Cartridge for AJ-1000
AI-CL	Cleaning Cartridge for AJ-1000

VersaUV LEC Series LEC-300A, LEC-330 & LEC-540



30" & 54" UV Print & Cut

Roland's DPI award-winning VersaUV LEC series quickly revolutionized the packaging prototype and short-run label industries.

For the first time, professionals could print CMYK plus White and Clear inks for varnishing and embossing effects on virtually any substrate and then crease, contour cut or perf-cut their designs, all on one device through one seamless workflow.

VersaUV uses safe, low-heat LED lamps to print on materials ranging from metallic and synthetic papers and foils to BOPP, PE and PET film, even leather and fabrics.

Roland ECO-UV inks produce graphics that are easy to handle and can be stretched across curved surfaces and sharp edges without cracking. With VersaUV, your prototypes and comps are so realistic, they are virtually indistinguishable from finished products.

Three models available:

- 54" LEC-540 – for faster print speeds and seamless production of larger, semi-rigid graphics
- 30" LEC-330 – high-speed performance and superior image quality, great for production printing of packaging prototypes, labels and specialty graphics
- 30" LEC-300A – our most affordable model, perfect for packaging prototyping, proofing, short run production and labels
- **Environmentally friendly ECO-UV inks:**
 - LEC-540/330 ink options
 - CMYK+White+Clear
 - CMYK+White+White
 - CMYK+Clear+Clear
 - LEC-300A - CMYK+White+Clear
- Prints, contour cuts, perf-cuts and creases designs
- Layered Clear produces unique textures and finishes including matte and gloss varnish and embossing effects

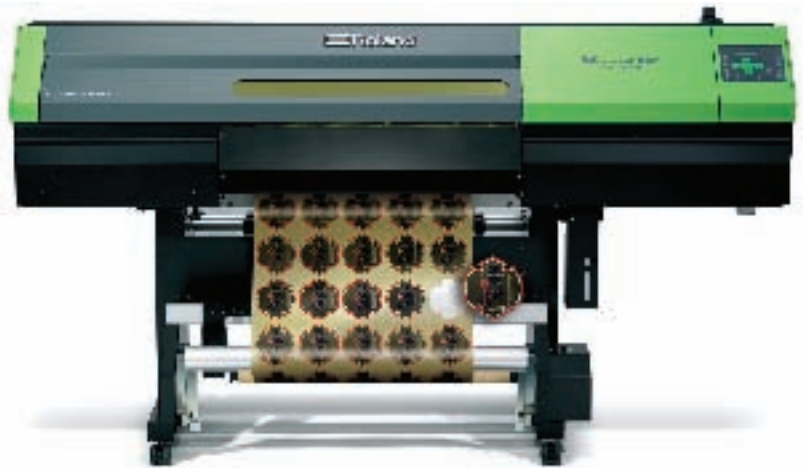

LEC-300A 30"
LIST ~~\$44,995~~

LEC-330 30"
LIST ~~\$62,995~~

LEC-540 54"
LIST ~~\$67,995~~

Call for Price!

Consult with us!

To avoid making a wrong – and costly – buying decision, make sure to talk to us. We know printers and the sign printing business inside out, and we'll do our best to help you select the printer that makes the most sense for your business. Because we represent top-quality manufacturers – and because we are committed to supporting our customers 100% before, during, and after the sale – we at S&F have the knowledge and experience to help you make the right decision.

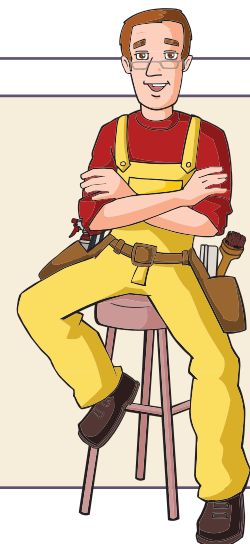

Inks



Roland Inks

Pigment/Dye Ink

For FJ Series

- Exceptional print quality for photographic and fine art giclees, backlits and other indoor applications
- Two color configurations available - CMYK+LcLm and CMYK+OG
- Simulates 97 percent of Pantone colors
- Boasts indoor durability of 100 years or more

Aqueous Pigment Ink, 220ml

ITEM NO.	COLOR
RMIFPG-CY	Cyan
RMIFPG-MG	Magenta
RMIFPG-YE	Yellow
RMIFPG-BK	Black
RMIFPG-LC	Light Cyan
RMIFPG-LM	Light Magenta
RMIFPG-OR	Orange
RMIFPG-GR	Green

Aqueous Dye Ink, 220ml

ITEM NO.	COLOR
FDY-CY	Cyan
FDY-MG	Magenta
FDY-YE	Yellow
FDY-BK	Black
FDY-LC	Light Cyan
FDY-LM	Light Magenta

Trimmers & Board Cutters

See Pages 85-86.

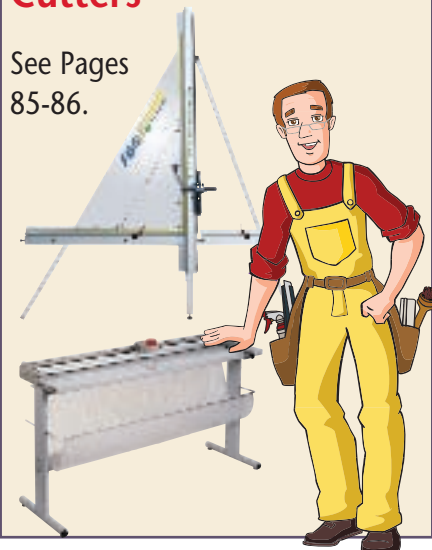

ECO-SOL MAX Ink

For SJ, XJ, RS, XC & VersaCMM Series

- Quick drying time for improved production speed
- Wider color gamut for reds, blues and greens
- Virtually odorless and user-friendly
- Durability up to three years outdoors without lamination



220ml Cartridges

ITEM NO.	COLOR
RMIESL3-BK	Black
RMIESL3-CY	Cyan
RMIESL3-MG	Magenta
RMIESL3-YE	Yellow
RMIESL3-LC	Light Cyan
RMIESL3-LM	Light Magenta
	White
	Silver Metallic



440ml Cartridges

ITEM NO.	COLOR
RMIESL3-4BK	Black
RMIESL3-4CY	Cyan
RMIESL3-4MG	Magenta
RMIESL3-4YE	Yellow
RMIESL3-4LC	Light Cyan
RMIESL3-4LM	Light Magenta

Eco Xtreme Ink 1000ml

for AJ Series



- Developed for industrial-strength performance
- Comes in 6 vivid colors (CMYK+LcLm)
- Performs across a wide range of coated and uncoated media

Choose from two formulations:

EcoXtreme Ink, 1000ml

- Rugged scratch, alcohol, water and UV resistance
- 3 years of outdoor durability

ITEM NO.	COLOR
RMIAI-BK	Black
RMIAI-CY	Cyan
RMIAI-MG	Magenta
RMIAI-YE	Yellow
RMIAI-LC	Light Cyan
RMIAI-LM	Light Magenta

EcoXtreme LT Ink, 1000ml

- Cost effective alternative for short-term applications
- 1 year of outdoor durability

ITEM NO.	COLOR
RMIAI2-BK	Black
RMIAI2-CY	Cyan
RMIAI2-MG	Magenta
RMIAI2-YE	Yellow
RMIAI2-LC	Light Cyan
RMIAI2-LM	Light Magenta

HeatWave Sublimation Ink 1000ml

- Consistent, clog-free printing
- Brilliant color with expanded color gamut

ITEM NO.	COLOR
SBL2-CY	Cyan
SBL2-MG	Magenta
SBL2-YE	Yellow
SBL2-BK	Black

HP 81 Dye / 83 UV Inks For Designjet 5000 Series

Ink Cartridges 680ml cartridge



HP 81 dye (indoor)

ITEM NO.	COLOR
CDHPC4930A	Black
CDHPC4931A	Cyan
CDHPC4934A	Light cyan
CDHPC4935A	Light magenta
CDHPC4932A	Magenta
CDHPC4933A	Yellow

HP 83 UV (outdoor)

ITEM NO.	COLOR	PRICE
CDHPC4940A	Black	
CDHPC4941A	Cyan	
CDHPC4944A	Light cyan	
CDHPC4945A	Light magenta	
CDHPC4942A	Magenta	
CDHPC4943A	Yellow	

Ink Cartridges Multipack



Contains three 680ml cartridges



HP 81 dye (indoor)

ITEM NO.	COLOR
CDHPC5066A	Black
CDHPC5067A	Cyan
CDHPC5070A	Light cyan
CDHPC5071A	Light magenta
CDHPC5068A	Magenta
CDHPC5069A	Yellow

HP 83 UV (outdoor)

ITEM NO.	COLOR
CDHPC5072A	Black
CDHPC5073A	Cyan
CDHPC5076A	Light cyan
CDHPC5077A	Light magenta
CDHPC5074A	Magenta
CDHPC5075A	Yellow

Printheads & Printhead Cleaners



HP 81 dye (indoor)

ITEM NO.	COLOR
CDHPC4950A	Black
CDHPC4951A	Cyan
CDHPC4954A	Light cyan
CDHPC4955A	Light magenta
CDHPC4952A	Magenta
CDHPC4953A	Yellow

HP 83 UV (outdoor)

ITEM NO.	COLOR
CDHPC4960A	Black
CDHPC4961A	Cyan
CDHPC4964A	Light cyan
CDHPC4965A	Light magenta
CDHPC4962A	Magenta
CDHPC4963A	Yellow

Value Pack

Contains ink cartridge,
printhead & printhead cleaner



HP 81 dye (indoor)

ITEM NO.	COLOR
CDHPC4990A	Black
CDHPC4991A	Cyan
CDHPC4994A	Light cyan
CDHPC4995A	Light magenta
CDHPC4992A	Magenta
CDHPC4993A	Yellow

HP 83 UV (outdoor)

ITEM NO.	COLOR
CDHPC5000A	Black
CDHPC5001A	Cyan
CDHPC5004A	Light cyan
CDHPC5005A	Light magenta
CDHPC5002A	Magenta
CDHPC5003A	Yellow

HP 91 Vivera Pigment Inks For Designjet Z6100 Series

Ink Cartridges 775ml cartridge



ITEM NO.	COLOR
CDHPC9464A	Matte Black
CDHPC9465A	Photo Black
CDHPC9466A	Light Gray
CDHPC9467A	Cyan
CDHPC9468A	Magenta
CDHPC9469A	Yellow
CDHPC9470A	Light Cyan
CDHPC9471A	Light Magenta

Ink Cartridges Multipack

Contains three 775ml cartridges

ITEM NO.	COLOR
CDHPC9480A	Matte Black
CDHPC9481A	Photo Black
CDHPC9482A	Light Gray
CDHPC9483A	Cyan
CDHPC9484A	Magenta
CDHPC9485A	Yellow
CDHPC9486A	Light Cyan
CDHPC9487A	Light Magenta

Printheads



ITEM NO.	COLOR
CDHPC9460A	Matte Black & Cyan
CDHPC9463A	Photo Black & Lt. Gray
CDHPC9461A	Magenta & Yellow
CDHPC9462A	Lt. Mag. & Lt. Cyan

Maintenance Cartridge



ITEM NO. C9518A

Inks • Solvent Printer Supplies

Quantum Ink for ENCAD NovaJet 1000i



Qi Pigment

Ink & Cartridge Kit

One foam-filled cartridge & one 700 ml ink bottle

ITEM NO.	COLOR
220880-00	Cyan
220881-00	Magenta
220882-00	Yellow
220883-00	Black
220884-00	Cyan Light
220885-00	Magenta Light

Refill Kit

One 700 ml ink bottle

ITEM NO.	COLOR
220035-00	Cyan
220036-00	Magenta
220037-00	Yellow
220038-00	Black
220039-00	Cyan Light
220040-00	Magenta Light

Qi Dye Ink

Ink & Cartridge Kit

One foam-filled cartridge & one 700 ml ink bottle

ITEM NO.	COLOR
220886-00	Cyan
220887-00	Magenta
220888-00	Yellow
220889-00	Black
220890-00	Cyan Light
220891-00	Magenta Light

Refill Kit

One 700 ml ink bottle

ITEM NO.	COLOR
220041-00	Cyan
220042-00	Magenta
220043-00	Yellow
220044-00	Black
220045-00	Cyan Light
220046-00	Magenta Light

HP 780 Ink Cartridges 500ml cartridges for 8000sr



ITEM NO.	COLOR
CDHPCB285A	Black
CDHPCB286A	Cyan
CDHPCB287A	Magenta
CDHPCB288A	Yellow
CDHPCB289A	Light Cyan
CDHPCB290A	Light Magenta

HP 790 Ink Cartridges 1000ml cartridges for 9000s/10000s



ITEM NO.	COLOR
CDHPCB271A	Black
CDHPCB272A	Cyan
CDHPCB273A	Magenta
CDHPCB274A	Yellow
CDHPCB275A	Light Cyan
CDHPCB276A	Light Magenta

Accessories for HP 8000sr Printer



Wiper Cleaning Kit

780 for HP 8000

ITEM NO. CDHPCB301A



Cap Cleaning Kit

780 for HP 8000

ITEM NO. CDHPCB302A



Waste Ink Bottle

780 for HP 8000

ITEM NO. CDHPCB291A



Accessories for HP 9000s Printer



Wiper Cleaning Kit

790 for HP 9000/1000

ITEM NO. CDHPCB293A



Cap Cleaning Kit

790 for HP 9000/1000

ITEM NO. CDHPCB294A



Waste Ink Bottle

790 for HP 9000/1000

ITEM NO. CDHPCB299A



Laminators

Liquid Laminator

EZ Glide Applicator

Great for protecting wide format prints i.e. outdoor signage (vinyls, scrim banner etc), fine art prints (water resistant canvas), vehicle and boat graphics.



- Applies a precise coating that's always smooth and even.
- Saves money by eliminating spray waste and heavy, streaky finishes from hand brushing.
- Much faster than spraying, brushing.
- Costs less than other coaters and faster than motorized coaters.
- Easy to use and easy to clean.

ITEM NO.	DESCRIPTION
DAI-LL38	38"
DAI-LL55	55"
DAI-LL62	62"

Entry Level Cold Laminator

Solo Daige Cold Laminator

Entry level laminator that provides essential features found on more expensive models including:

- Top and bottom nip rollers covered with hard silicone
- Rigid steel cores in top roller for better pressure
- Heavy duty motor
- Spring loaded top roller
- Rugged steel and aluminum construction
- Accommodates boards up to 1/2" thick (can be made for 1" thick boards upon request).
- Available in 25", 38", 55" and 65" widths.



ITEM NO.	DESCRIPTION
DAI-SOLO25	25" Laminator
DAI-SOLO38	38" Laminator
DAI-SOLO55	55" Laminator
DAI-SOLO65	65" Laminator

Optional Accessories

Stand

Steel stand with four castors provides mobility and saves table space.

Footswitch

Provides hand free control.

Cold Laminators

RSC-1400C

55" Cold Laminator

RSC-1650C

65" Cold Laminator



- Fast - Laminates pressure sensitive up to a rate of 16.4' per minute.
- Quality - Digital controls, combined with silicone rubber rollers help deliver a perfect finish.
- Versatility - Designed for mounting (up to .6"), laminating individual or multiple copies of posters prints, POP signs, training aids, rigid or flexible signage, inkjet, photo, floor graphics and much more.
- Easy To Use - Simple one button operation plus remote control and foot pedal allow hands-free operation.

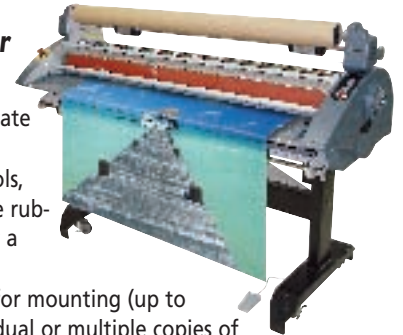

ITEM NO.	DESCRIPTION
CDRSC1400-C	55" Cold Laminator
CDRSC1650-C	65" Cold Laminator

Arctic

1040Wfc 38" Cold Laminator

1064Wfc 61" Cold Laminator



The Arctic 1064Wfc laminates and mounts with pressure-sensitive films and adhesives up to 61" wide, while the Arctic 1040Wfc handles films and adhesives up to 38" wide. Production level speeds allow you to finish prints quickly and easily.



- Convenient motor-driven rewind for release liner, with brake adjustment
- Adjustable speed for operator comfort
- Foot pedal allows hands-free operation
- Print baskets catch output and store film
- Roller gap adjusts up to 1/2" for mounting
- Large diameter, easy-to-clean silicone rollers provide clear output fast

ITEM NO.	DESCRIPTION
GBC3600230	38" Cold Laminator
GBC3600234	61" Cold Laminator

Laminators

Heat Assist Laminators

Gfp 400 Series

Heat Assist Laminators



The Gfp 400 Series laminators are money makers. Easy to operate, they're a favorite with operators that prefer a simple time-saving set-up and variable roller gap adjustment. Ruggedly built for applications that require overlamination, mounting or the pre-coating of boards, the 400 Series laminators are available in 55" and 63" widths. Thanks to oversized rollers and 1 inch roller gap, you'll be making money in no time.

- Roller diameter 4.5"
- Variable roller gap to 1"
- Speed and temperature controls
- Reverse switch
- Foot pedal
- Swing up feed table
- One-year warranty - parts & labor



In Stock, Ready to Ship!



Simple, easy to use speed and temperature controls



Optional motorized rear rewind for roll-to-roll applications

ITEM NO.	DESCRIPTION
CDGFP455TH	55" Cold/Hot Laminator
CDGFP463TH	63" Cold/Hot Laminator

RSC-1400H 55" RSC-1650H 65"

Cold/Heat Assist Laminator

Same features as the RSC-1400C/1650C with added top roller heat assist.



ITEM NO.	DESCRIPTION
CDRSC1400-H	55" Cold/Hot Laminator
CDRSC1650-H	61" Cold/Hot Laminator

What to look for when buying a laminator?

The following types of laminators are available:

Cold laminators

Ideal for laminating heat-sensitive media with pressure-sensitive laminates.

Heat Assist Laminators

Top roller is heated to assist in laminating with pressure-sensitive laminates for better results

Hot Laminator

Are generally heated with one or more heated rollers. Heated laminators can process heat-activated, heat-assist or pressure sensitive materials.

Consider the widest prints you currently produce or use to produce graphics that require lamination to determine the laminator width you will need.

Approximate the volume of prints you would likely produce in a day or week to determine which model will meet your production demands.

An average laminator can mount on boards up to 1/2" thickness. Some models will mount up to 1" thick.

Remember!

Unlike some printers or other equipment, a good laminator will not become obsolete a short time after its installation.

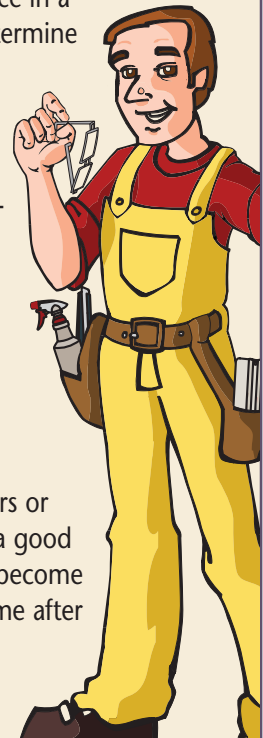

Laminators • Trimmers

Cold/Hot Laminator

RSH-1651

65" Cold/Hot Laminator

Designed for mounting, laminating & encapsulating. This advanced hot roller system allows large format inkjet output to be laminated with superior quality. P.I.D. control Microprocessor provides stable temperature condition on the roller while laminating the material and also allows user to manipulate the temperature as required.

- Laminates pressure sensitive and thermal film up to 65" wide at a rate of 6.6' per minute.
- Digital controls for temperature and speed help deliver a perfect finish.
- Simple one button operation plus remote control and foot pedal allow hands-free operation.
- Nine job memory setting feature for frequently used settings.



Titan 1244WF 43"/1264WF 63"

Thermal or Cold Laminating

The Titan Series laminators make high quality lamination easy, cost-effective and safe, even for beginners. The built-in sophistication ensures a professional finishing job — thermal or cold — every time. Designed to work with wide-format pressure-sensitive and thermal films. The Titan 1244WF laminates up to 43" wide, while the Titan 1264WF can laminate up to 63" pressure-sensitive film and up to 61" wide for the thermal film.

- Rewind and unwind shafts accommodate PSA and AccuShield release liners
- High-quality clutch ensures consistently flat output
- Nine job memory settings recall frequently used jobs
- Film shaft swings out for easy loading and unloading.
- Temperature and speed settings controlled electronically



Call for Price!

1244WF
LIST ~~\$11,995~~

1264WF
LIST ~~\$15,995~~

GBC 2064WF 64"

Thermal or Cold Laminating

The 2064WF can laminate and mount a variety of thermal and PSA films and materials up to 64" wide and 1" thick with speeds up to 15 fpm.

Ideal for mid-range production quantities nearing high-end production.

- Swing-out film shafts simplify film loading
- Bi-directional productivity allows hot and cold jobs to be run consecutively.
- Control settings are located on front and back sides of the unit.
- Roll-to-roll applications benefit from an edge roller on the front feed table and a curved trailing edge on the rear feed table.
- Heat rollers and pull rollers are independently adjustable.
- Digital display indicates film footage to maximize roll usage.



Call for Price!

LIST ~~\$20,995~~

Rotary Trimmer



DigiJet Rotary Trimmer

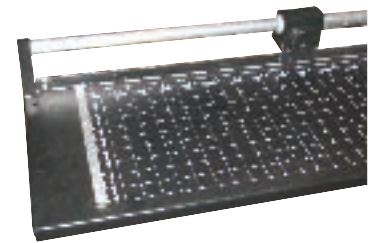

ITEM NO.	SIZE
DIGIHRC63	63" Rotary Trimmer
DIGIHRC82	82" Rotary Trimmer w/stand
DIGIHRC-ST	63" Stand & Basket
DIGIHRCRH	Replacement Head
DIGIHRCRK	Replacement Rotary Knife



ProTrim 45/63

Precision Rotary Cutting System 45" or 63"

The specially designed and engineered ProTrim cutters meet the demands of the digital imaging and finishing markets.



Trim prints and laminated materials up to 20 mil thick.

- Bi-directional cutting action accommodates both right and left-handed operators
- Self-actuating clamping system holds your materials in place while the blade is in motion
- An open-ended design enables the trimming of extra-large banners in one continuous cut

ProTrim 45
LIST ~~\$1,375~~

ProTrim 63
LIST ~~\$1,795~~

Cutters & Trimmers

Substrate Cutter/Trimmer

DigiJet Board Cutter

Cut and trim on the same machine!



- Provides straight, square and accurate cutting of lite board materials up to 1/2" thick and flexible materials
- Cutter stand and basket included
- Uses standard utility knife blades
- Open-ended design allows for cutting oversized materials

ITEM NO.	SIZE
DIGIHBC60	60" Cutter/Trimmer
DIGIHBC100	100" Cutter/Trimmer
DIGIHBCRH	Replacement Head
DIGIHBCRK	Replacement Blade (100)

Titan Board Cutter

Cut and trim on the same machine!



- Provides straight, square and accurate cutting of lite board materials up to 1/2" thick and flexible materials
- One-piece aluminum base with integrated blade cutting track and trimming surface
- Open-ended design allows for cutting oversized materials
- Available in widths up to 120"

ITEM NO.	SIZE
CDFL-TITAN-40	40"
CDFL-TITAN-60	60"
CDFL-TITAN-80	80"
CDFL-TITAN-100	100"
CDFL-TITAN-12	120"

GeminiPro Rail Cutter



- Provides straight, square and accurate cutting of foamboard, corrugated plastics and flexible materials up to 1/2" thick
- Precision aluminum extrusion, engineered for straightness
- Ability to either cut with a blade or trim with a trimmer wheel on the same unit
- Adaptable with Atlas workbench to provide a total flat, square and stable cutting system

ITEM NO.	SIZE
CDFLGP40	40"
CDFLGP60	60"
CDFLGP80	80"
CDFLGP100	100"
CDFLGP12	120"

Atlas Worktable

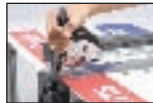
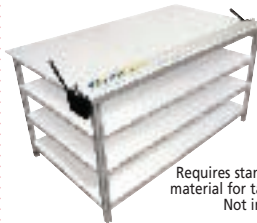

Requires standard 3/4" thick material for table top surface. Not included.

- Works with Fletcher's GeminiPro rail cutters, for creating a cutting system
- Equipped with "lift & shift" elevators that lifts the cutting rail for material positioning
- Provides a flat, straight and sturdy cutting surface
- Base is made from anodized aluminum that will not warp, twist or bow resulting in a solid and sturdy work station

ITEM NO.	SIZE
CDFLGP40	40"
CDFLGP60	60"
CDFLGP80	80"
CDFLGP100	100"
CDFLGP12	120"

FSC Substrate Cutter

Cut clean, straight, accurate and debris-free!



The FSC is an affordable finishing solution designed for virtually any sign making or graphic development business. Cut materials such as Acrylic, Alupalite, Aluminum (.063), Dibond, Polycarbonate, Corrugated plastic, Foamboards, PVC, etc.

Optional cutting wheel (not included) needed to cut aluminum.

- Wall mounted or free-standing unit
- 65" cutting capacity
- Cutting head design features quick interchange blade and wheel cutting tools
- Includes Laser Sight Line Cutting Guide that projects a cut line on the substrate, eliminating guess work

ITEM NO. CDSL-FSC65

Need help selecting the right product?

The knowledgeable sales team at S&F will be able to assist and advise you in choosing the product that will best fit your application.





www.sfsupplies.com



INDEX

DIGITAL MEDIA	5
SIGN VINYL	45
VINYL AND WRAP SUPPLIES	59
WIDE FORMAT EQUIPMENT	73
VINYL CUTTERS	87
Roland Vinyl Cutters88-89 Graphtec Vinyl Cutters90-91 Cutter Blades & Pens92-94	
ENGRAVERS	95
SOFTWARE	97
SUBSTRATES	105
BANNER	127
SIGN DISPLAY	139
TAPES & ADHESIVES	145
PAINT	153
NEON SUPPLIES & EQUIPMENT	167
TRANSFORMERS	207
LED SYSTEMS	229
LIGHTING & ELECTRIC	243
SIGN EXTRUSION	267
LETTER & ACCESSORIES	277
MOUNTING HARDWARE	281
EQUIPMENT & SHOP TOOLS	293

Roland Vinyl Cutters

CAMM-1 Servo GX-24 24" Desktop Vinyl Cutter



The GX-24 desktop vinyl cutter offers enhanced productivity and quality. Powered by a digital servomotor, it achieves cutting speeds up to 20 inches per second and maximum accuracy. Vehicle graphics, signs, decals, labels, stencils and even pinstriping always come out looking crisp and clean.



- Recognizes crop marks produced by a variety of print-only devices
- Accepts material from two to 27.5 inches wide
- Ideal for Vinyl, paint mask, reflective vinyls, twill, heat transfer, and sandblast
- USB and serial connectivity
- Roland CutStudio™ Software included
- Includes Windows printer driver, a plug-in for Adobe Illustrator (OS 9/X for Mac) & CorelDRAW.
- Optional stand available

GX PRO Series Vinyl Cutter



Professional Graphics Production

In addition to Roland's legendary reliability, the GX Pro offers enhanced versatility and ease of use. Its ability to contour cut pre-printed graphics lets you create professional vehicle wraps and even heat transfers for garments.



- Cutting material up to 33" per sec.
- Max down force of 350 grams
- USB and serial connectivity
- Optical registration system facilitates accurate contour cutting
- Roland CutStudio™ Software included
- Plug-ins for Adobe® Illustrator and CorelDRAW®

Call for Price!

Available in the following sizes:

MODEL	MEDIA SIZE	CUTTING SIZE	LIST PRICE
GX-300	36"	30"	\$3,295.00
GX-400	46"	40"	\$4,295.00
GX-500	54"	48"	\$5,295.00

CAMM-1 Pro GX-640 64" Vinyl Cutter

The Industry's Most Technologically Advanced Cutter!

The largest, most technologically advanced cutter Roland has ever produced. Perfect for grand-format jobs ranging from signs and banners to vehicle restyling, floor graphics and more, the GX-640 also features revolutionary Roland Quadralign™ technology to precisely read crop marks on pre-printed data. This makes it an excellent complement to Roland VersaArt and SOLJET XJ printers for full contour-cutting color graphics of virtually any size and shape.

- Quadralign™ optical registration system (with Roland VersaWorks) for cutting pre-printed graphics
- 3 cut modes for exceptional quality
- Front and rear loading
- Optional catch basket and cover
- Automatic sheet cut function
- Overcut and Autocut functions
- Overlap function for cutting thicker media such as prismatic reflective vinyl and monument grade sandblast



Call for Price!

MODEL	MEDIA SIZE	CUTTING SIZE	LIST PRICE
GX-640	72"	65"	\$3,295.00

Roland Vinyl Cutters

Blades

for Roland Plotters/Printers

Generic Blades

Replaces Roland Standard Blades



ITEM NO.	ANGLE
LYCB1330	30°
LYCB1345	45°
LYCB1360	60°



High-Strength Carbide Blades

For Cast & Calendered Vinyl

ITEM NO.	ANGLE	PACK
CDRBZECU1005	45°	1

For Detail & Small Lettering

ITEM NO.	ANGLE	PACK
CDRBZECU5025	45°	5

For Sandblast & Laminated Vinyl

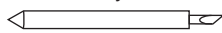

ITEM NO.	ANGLE	PACK
CDRBZECU1715	45°	5

For Reflective Vinyl, Flock, Twill, Paint Protection Film

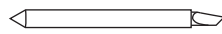

ITEM NO.	ANGLE	PACK
CDRBZECU3050	60°	5

For Safety & Security Film

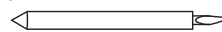

ITEM NO.	ANGLE	PACK
CDRBZECU3100	60°	5

Cross Cutter Blade



ITEM NO.	DESCRIPTION
CDRBUSBLADEKB	Pack of 25

Plotter Pens for Roland Plotters

9300 Series

Designed with a special high pressure reservoir to maintain smooth ink flow while plotting at high speeds. The large reservoir provides 4 miles of plotting usage.



ITEM NO.	COLOR
LYCB9301	Black
LYCB9302	Blue
LYCB9303	Red

Fiber Tip Plotter Pen

A one-piece pen with a bonded fiber, or nylon plotting tip. Comes in a 5 pack of black or a pack of assortment containing one of each; black, green, blue, yellow and red.



ITEM NO.	COLOR
LYPMBLK	Black
LYPMMIX	Assorted Colors

Blade Holders for Roland Plotters/Printers



ITEM NO.	DESCRIPTION
CDRSPXDCH3	Plastic
CDRSPXDCH2	Metal

Cutter Protection Strip

ITEM NO.	DESCRIPTION
CDRXDCPS24	for GX-24
CDRXDCPS5	for CX-24
CDRXDCPS30	for CM-300,CX-300
CDRXDCPSGX3	for GX-300
CDRXDCPSGX4	for GX-400
CDRXDCPSGX5	for GX-500

All cutting strips for previous models are available.

Replacement Parts

Bolt Pen Holder

ITEM NO. CDRSP21815101



Nut Pen Holder

ITEM NO. CDRSP22285503



Pinch Roller

For side: ITEM NO. CDRSP21565102

For center: ITEM NO. CDRSP21565103



Pinch Roller Lever

ITEM NO. CDRSP22145616



Digital Graphics Showrooms

Our showrooms are always set up with the latest models of plotters, large format printers, laminators etc. Our trained technicians are ready to give you a free demonstration on any of the equipment.

Please call to schedule an appointment.



Graphtec Vinyl Cutters

Craft ROBO Pro



15" Professional, Portable Media Cutting Plotter

Perfect for all kinds of media cutting applications including vinyl, heat and image transfers, contour cut (die cut) stickers, labels, etc.



- Maximum cutting width of 14.8 inches
- Maximum speed up to 16 inches per second
- Cutting force up to 300gf
- Automatic Registration Mark Sensor

CE5000 Series



Engineering Class Cutting Plotters

CE5000 is Graphtec's leading price/performance cutter. Providing an ideal solution for cutting a wide variety of materials. Available in two sizes—48" & 24".



- Fast & Accurate Digital Servo Motors
- 4-Point, Dual-Axis Skew Correction
- Tangential Control enhances precision
- ROBO Master Pro with Auto Tracing
- Cutting Master 2 plug-in software—PC & Mac

MODEL	SIZE
CE5000-60	24"
CE5000-120	48"

FC8000 Series



High-Performance Cutting Plotters

Cutting Plotter Controller Software Utility

- Control functions of the FC8000 from your computer

Next Generation ARMS System (Auto Registration Mark Sensor)

- Sensitivity adjustment for registration mark detection on various media and colors
- Optical sensor for auto alignment



Three Step Push-Roller Pressure Settings

- Strong (ie: sandblast mask, high-intensity reflective)
- Medium (ie: vinyl)
- Light (ie: window tint film) *standard with FC8000-100, -130 & -160

USB 2.0, RS-232 Serial & Optional Ethernet Interface

- Ethernet Interface allows for one PC to run multiple FC8000s

Dual Configuration Function

- Two different users can set & save independent settings for customized jobs on a single FC8000 machine

Call for Price!

Available in the following sizes:

MODEL	MEDIA SIZE	CUTTING SIZE	LIST PRICE
FC8000-60	30"	24"	\$2,995
FC8000-75	36"	30"	\$3,995
FC8000-100	48"	42"	\$4,995
FC8000-130	60"	54"	\$5,995
FC8000-160	72"	64"	\$6,995

FC2250 Series - Large Flatbed With ARMS



The FC2250 Large Format flatbed cutting plotter is available in 3 table sizes — 24"x36", 47"x36" and 68.5"x36" table sizes, with optional tool head configurations and material hold-down systems. Dual Head Design features 500 grams and 1000 grams maximum down force for more efficient marking and cutting workflows.

The FC2250 large format flatbed cutting plotters are ideal for designers and prototyping in the offset printing, digital printing, packaging industry, fashion industry, as well as road sign making, stone & glass sandblasting/etching, electronic film industry, etc.

- Dual Head Design: 500/1000 grams Cutting Force
- 3 Media Hold down methods available: Electrostatic, Vacuum or Magnetic
- Operate in Horizontal or Inclined Model (Vacuum table-horizontal only)
- D-Cut Software imports DXF Data
- Cutting Master Plug-in for Adobe Illustrator®
- 0.118" (3mm) Blade for cutting thicker material up to E FLute
- New Optional Creasing Tool for Corrugated Media

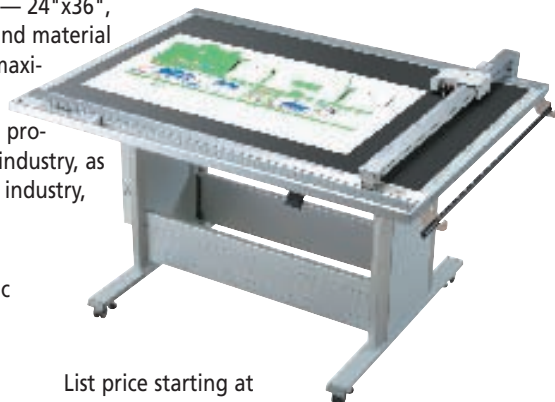

List price starting at
\$12,995⁰⁰

Graphtec Vinyl Cutters

Blades & Blade Holders for Graphtec Plotters



GRAPHTEC
WESTERN GRAPHTEC, INC.

0.9mm Supersteel Blade

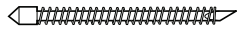

Standard blade for cutting media up to 0.25 mm thick.

ITEM NO.	ANGLE	PACK
CDGCB09UA	45°	1 pack

0.9mm, Blue Top Blade Holder



ITEM NO.	TIP
CDGBH9	Black ABS Tip
PHP31-CB09-HS	Brass Tip

0.9mm Carbide Tipped Blade

Replaces Graphtec Standard Blade. No spring included.



ITEM NO.	ANGLE	PACK
LYCB1945	45°	1 pack
LYCB1960	60°	1 pack

GRAPHTEC
WESTERN GRAPHTEC, INC.

1.5mm Supersteel Blade



Recommended for cutting sandblast rubber up to 2.5 mm thick. (FC8000)

ITEM NO.	ANGLE	PACK
CB15U-K20-2SP	20°	2 pack

1.5mm, Green Top Blade Holder

for CB15 SP blades



ITEM NO.	TIP
CDGBHCB15B-HS	Brass Tip

GRAPHTEC
WESTERN GRAPHTEC, INC.

1.5mm Supersteel Blade

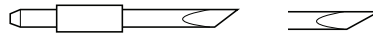

For cutting media from 0.25 mm to 0.5 mm thick. The 30° is suitable for cutting media up to 1.5 mm thick.

ITEM NO.	ANGLE	PACK
CDGCB15U	45°	1 pack
CDGCB15U-5SP	45°	5 pack
CB15U-2	45°	2 pack
CDGCB15U-K30-5S	30°	5 pack
CDGCB15UK30	30°	2 pack

1.5mm Supersteel Blade

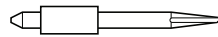

For cutting small characters that are less than 10mm.

ITEM NO.	ANGLE	PACK
CDGBCB15UB-2		2 pack

1.5mm, High-intens, Reflective



For cutting high intensity reflective media.

ITEM NO.	ANGLE	PACK
CDGBCB15UA-5	45°	5 pack
CDGBCB15UA-2	45°	2 pack
CB15UA-K30-5	30°	5 pack
CB15UA-K30-2	30°	2 pack

1.5mm, Red Top Blade Holder



ITEM NO.	TIP
CDGBH15	Black ABS Tip
CDGCBH15N-1	Brass Tip

Teflon Cutting Mat for Graphtec Plotters

ITEM NO.	MODEL
CDGTSCE1000	CE Series 24"
CDGTSCE5000-60	CE-5000-60
CDGTSCE5000-120	CE-5000-120
CDGTS4100	FC4100-75
CDGTS4100-100	FC4100-100
CDGTS4100-130	FC4100-130
CDGTS5100-75	FC5100-75
CDGTS5100-130	FC5100-130
CDGTS5100-150	FC5100-150

For FC8000, FC7000Mk2, FC7000

ITEM NO.	MODEL
CDGTSFC7000-60	60
CDGTSFC7000-75	75
CDGTSFC7000-100	100
CDGTSFC7000-130	130
CDGTSFC7000-160	160

All cutting strips for previous models are also available.

Plotter Pens for Graphtec Plotters

9500 Series

Designed with a special high pressure reservoir to maintain smooth ink flow while plotting at high speeds. The large reservoir provides 4 miles of plotting usage.



ITEM NO.	COLOR
LYCB9501	Black
LYCB9502	Blue
LYCB9503	Red

Ball Point Pen

GRAPHTEC
WESTERN GRAPHTEC, INC.

ITEM NO.	COLOR
CDGB53001-069	Black

GRAPHTEC
WESTERN GRAPHTEC, INC.

Fiber Tip Pen

5 pack.



ITEM NO.	COLOR	PACK
CDGCPFT	Black	5
KF550-S1	2 Black, 1 Red, 1 Blue, 1 Green	5
KF550-F8	1 ea. Black, Red, Violet, Brown, Blue, Green, Orange, Pink	8

Cross Cutter Blade



ITEM NO.	DESCRIPTION
CDGSPCT01H	Standard
CDGSPCT02U	Supersteel

Pinch Roller

For all Graphtec Plotters



ITEM NO.
CDGSP621352000

Cutter Blades & Pens

For vinyl with standard thickness, a 45° blade will usually be used, a 30° blade for less than 4 mil thickness, and a 60° blade for 12+ mil thickness i.e. reflective material. This is only a guide and may vary by plotter.



Blade Index

MODEL	ITEM NO.
Accutrac 439	SC-1600 Series
Allen Datagraph 936/800	SC-1300 Series
Anagraph Excel-5/Excel-2, Excel-EM	SC-1200 Series
Anagraph AE-Series	SC-3600 Series
Anagraph Excel 1/1m	SC-1000 Series
Anagraph-EMS	SC-1300 Series
Aristo AR-20/AR-50 Lettering Systems	
AG-50, AG-75, AG-130, Signline Series	SC-2100 Series
Compugraphy	SC-1000 Series
CSR Ecom-2	SC-1300 Series
Gerber DCS 1500	SC-4700 Series
Gerber Emboss Track	SC-3800 Series
Gerber GSX	SC-2700 Series
Graphic CE/FC-Series	SC-1900 Series
GRI	SC-3300 Series
Houston-Inst. DMP Series	SC-1600 Series
HTD Density 4000	SC-1600 Series
Ioline 5000	SC-1500 Series
Ioline Studio 7/8 Artpro Series/ Super 88	SC-1400 Series
Jorlink	SC-1600 Series
K-Cad Cal-Comp	SC-3700 Series
Mimaki CG-Series	SC-2000 Series
Mutoh SC-Series	SC-4100 Series
Mutoh XP-Series	SC-3800 Series
Newing-Hall	SC-1600 Series
Roland (all)	SC-1300 Series
Summagraphics D-Series	SC-3300 Series
TC-1100 Turbo Cut Tool	SC-1145
TC-1101 / TC-1102 Turbo Cut Tools	SC-1130
Techno-Arts Bladerunner	SC-1500 Series
Techno-Arts Switchblades	SC-1400 Series
Vytek 500 / 1000	SC-1600 Series
Zeta CP30/CP3015	SC-2200 Series

SC-1000 Series

TARGET PLOTTERS:

- Gerber III/IV, S/750 Sprint Series Lettersmith
- Anagraph Excel 1/1m
- Compugraphicart



ITEM NO.	ANGLE
LYCB1030	30°
LYCB1045	45°
LYCB1060	60°

Carbide Plotter Blades

SC-1100 Series

TARGET PLOTTERS:

- TC-1101 / TC-1102 Turbo Cut Tools



ITEM NO.	ANGLE
LYCB1130	30°

TARGET PLOTTERS:

- TC-1100 Turbo Cut Tool

ITEM NO.	ANGLE
LYCB1145	30°
LYCB1160	60°

SC-1200 Carbide Series

TARGET PLOTTERS:

- TC-1101 / TC-1102 Turbo Cut Tools



ITEM NO.	ANGLE
LYCB1230	30°
LYCB1260	60°

SC-1300 Carbide Series

TARGET PLOTTERS:

- Allen Datagraph 936/800
- CSR Ecom-2 • Anagraph - EMS
- Vinyl Express • Roland (all)



ITEM NO.	ANGLE
LYCB1330	30°
LYCB1345	45°
LYCB1360	60°

SC-1400 Series

TARGET PLOTTERS:

- Techno-Arts Switchblades
- Classic
- Ioline Studio 7/8 Artpro Series / Super 88



ITEM NO.	ANGLE
LYCB1430	30°
LYCB1445	45°
LYCB1460	60°

SC-1500 Series

TARGET PLOTTERS:

- Ioline 5000
- Techno-Arts Bladerunner
- Signature 45



ITEM NO.	ANGLE
LYCB1530	30°
LYCB1545	45°
LYCB1560	60°

SC-1600 Series

TARGET PLOTTERS:

- Houston-Inst. DMP Series
- HTD Destiny 4000 • Vytek 500 / 1000
- Newing-Hall • Accutrac 439 • Jorlink



ITEM NO.	ANGLE
LYCB1630	30°
LYCB1645	45°
LYCB1660	60°

SC-1900 Series

TARGET PLOTTERS:

- American Graphtec Cutting Pro / FC-Series



ITEM NO.	ANGLE
LYCB1945	45°
LYCB1960	60°

SC-2000 Series

TARGET PLOTTERS:

- Mimaki CG-Series
- New Star



ITEM NO.	ANGLE
LYCB2037	37°
LYCB2040	40°
LYCB2056	56°

SC-2100 Series

TARGET PLOTTERS:

- Aristo AR-20/AR-50 Lettering systems, AG-50 AG-75 AG-130 Signline Series



ITEM NO.	ANGLE
LYCB2135	35°
LYCB2160	60°

SC-2200 Series

TARGET PLOTTERS:

- Zeta CP30 / CP 3015



ITEM NO.	ANGLE
LYCB2245	45°
LYCB2260	60°

SC-2700 Series

TARGET PLOTTERS:

- Gerber GSX, GXX-Plus, HS Swivel



ITEM NO.	ANGLE
LYCB2742	42°
LYCB2760	60°

Cutter Blades & Pens

Carbide Plotter Blades

SC-3300 Series

TARGET PLOTTERS:

- Summagraphics D-Series
- GRI



ITEM NO.	ANGLE
LYCB3335	35°
LYCB3360	60°

SC-3600 Series

TARGET PLOTTERS:

- Anagraph AE-Series (Anagraph Express)
- Elite



ITEM NO.	ANGLE
LYCB3645	45
LYCB3645	60°

SC-3700 Series

TARGET PLOTTERS:

- K-Cad Cal-Comp



ITEM NO.	ANGLE
LYCB3745	45°
LYCB3760	60°

SC-3800 Series

TARGET PLOTTERS:

- Mutoh XP-Series
- Gerber Emboss Track, Invision



ITEM NO.	ANGLE
LYCB3830	30°
LYCB3845	45°
LYCB3860	60°

SC-4100 Series

TARGET PLOTTERS:

- Mutoh SC-Series
- Gerber Fast Track



ITEM NO.	ANGLE
LYCB4130	30°
LYCB4145	45°
LYCB4160	60°

SC-4700 Series

TARGET PLOTTERS:

- Gerber DCS 1500

ITEM NO.	ANGLE
LYCB4745	45°
LYCB4746	60°

Tool Blade Adapter

Allows cutting at 2x to 4x the normal speed! This unique tool holder is engineered with a high-tech precision ball bearing swivel unit, permits cutting of materials in the "pen-plot" mode. Best results are achieved when cutting 1" letters and up.

TC-1100

TARGET PLOTTERS:

- Gerber IVB, S/750 Sprint Series
- Lettersmith, GS-15

One SC-1145 blade included.



ITEM NO. LYCBTC1100

TC-1101

TARGET PLOTTERS:

- Gerber III, IV, IVA Series

One SC-1130 blade is included



ITEM NO. LYCBTC1101

TC-1102

TARGET PLOTTERS:

- Anagraph Excel-5, Excel-EM

One SC-1130 blade is included



ITEM NO. LYCBTC1101

Plotter Pens

Designed with a special high pressure reservoir to maintain smooth ink flow while plotting at high speeds.

SP-9000 Pen Series

TARGET PLOTTERS:

- Gerber Signmaker Graphix 4 / 4B / 4E
- Gerber Sprint
- Gerber S / 750
- Gerber Graphix 2
- Anagraph Excel 1 / 1m



ITEM NO.	COLOR
LYCP9001	Black
LYCP9002	Blue
LYCP9003	Red

SP-9200 Pen Series

TARGET PLOTTERS:

- AnagraphXL-5/XL-2

Replacement for 10146-01 pens.



ITEM NO.	COLOR
LYCP9201	Black
LYCP9202	Blue
LYCP9203	Red

SP-9500 Pen Series

TARGET PLOTTERS:

- Graphtec
- Anagraph AE-70/100
- Anaexpress



ITEM NO.	COLOR
LYCP9501	Black
LYCP9502	Blue
LYCP9503	Red

SP-9100 Pen Series

TARGET PLOTTERS:

- Gerber Supersprint
- Gerber HS-15, GS-15, HS / 750 GS / 750
- Gerber Lettersmith



ITEM NO.	COLOR
LYCP9101	Black
LYCP9102	Blue
LYCP9103	Red

SP-9300 Pen Series

TARGET PLOTTERS:

- Roland • Ioline
- Gerber Emboss Track
- Allen DataGraphic
- Gerber 510 • Mutoh XP-500
- HP Draftmaster • Mamaki























ITEM NO.	COLOR
LYCP9301	Black
LYCP9302	Blue
LYCP9303	Red

Graphtec Blades

Blade Application and Features

Individual Cutter Blades have a variety of features. Select the optimal Cutter Blade to suit the medium (vinyl, card, rubber, etc.) to be cut.

Blade part no. and Type	Diameter	Plunger (holder) part no.		Applications and features
		Current Models	Older Models (e.g. FC5100)	
CB09UA 	0.9 mm		PHP32-CB09N-HS 	Standard Blade for cutting Color Adhesive media (standard vinyl). Suitable for cutting media up to 0.25mm thick. Max cutting distance of approximately 4000 meters. (CE5000, FC8000, FC2250, FC4200, FC4210)
CB15U 	1.5 mm		PHP31-CB15-HS 	For cutting media which is too thick for the CB09UA Blade. Suitable for cutting media from 0.25mm to 0.5mm thick. (CE5000, FC8000, FC2250, FC4200, FC4210)
CB15UA 	1.5 mm		PHP31-CB15-HS 	For cutting High Intensity Reflective media. (CE5000, FC8000, FC2250, FC4200, FC4210)
CB15UB 	1.5 mm		PHP32-CB15N-HS 	For cutting small characters on Mono-Vinyl Chloride media. Suitable for cutting Small Size Characters that are less than 10mm. (CE5000, FC8000, FC2250, FC4200, FC4210)
CB15U-K30 	1.5 mm		PHP32-CB15N-HS 	For thick media. The sharply angled point provides a longer cutting edge. Suitable for cutting material from 0.5mm to 1.5mm thick. (CE5000, FC8000, FC2250, FC4200, FC4210)
CB15U-K20-SP 	1.5 mm		PHP31-CB15B-HS 	For cutting Sandblast Rubber up to 2.5mm thick. (FC8000, FC2250)
CB30UC 	3.0 mm		PHP34-CB30-HS 	For cutting Corrugated Paper up to E flute or Chip Board up to 2.0mm thick. (FC2250)



www.sfsupplies.com



INDEX

DIGITAL MEDIA	5
SIGN VINYL	43
VINYL AND WRAP SUPPLIES	57
WIDE FORMAT EQUIPMENT	69
VINYL CUTTERS	83
ENGRAVERS	95
Roland Engravers96	
SOFTWARE	97
SUBSTRATES	105
BANNER	127
SIGN DISPLAY	139
TAPES & ADHESIVES	145
PAINT	153
NEON SUPPLIES & EQUIPMENT	167
TRANSFORMERS	207
LED SYSTEMS	229
LIGHTING & ELECTRIC	243
SIGN EXTRUSION	267
LETTER & ACCESSORIES	277
MOUNTING HARDWARE	281
EQUIPMENT & SHOP TOOLS	293

Engravers

EGX-30

Desktop Engraver

The EGX-30 provides the most cost-effective, computerized engraving solution available. Engineered for busy professionals looking for a second machine and beginners working on a limited budget, the EGX-30 engraves badges, nameplates, key rings, and luggage tags. It also scribes brass for awards and trophies.

- Convenient, 12-by-8-inch work area
- Surface detection at the push of a button
- Quiet operation
- Engraving software included
- Rail tracking for smooth engraving



Call for Price!

LIST ~~\$2,995~~

EGX-350

Desktop Engraver

The EGX-350 has what it takes to give your customers what they really want! Powered by a 20000 rpm DC brushless motor, the desktop engraver produces a wide range of popular jobs with crisp text and clear graphics. Indoor signs, gifts and awards, and custom rhinestone apparel all turn out perfectly.

- Safe & easy to operate
- Engraving software & tools included
- Optional Jigs & vices available
- Convenient, 12-by-9-inch work area
- Advanced surface detector
- Hand-held control panel with a large backlit LCD screen



Call for Price!

LIST ~~\$5,495~~

EGX-400 & EGX-600

Roland EGX Pro engravers have the power, size and speed professional engravers need. In addition to personalized awards, corporate crests and promotional items, these benchtop devices are part of a complete solution for producing quality indoor and ADA compliant signage. Your signs will have an upscale look while meeting all ADA regulations.

Maximum work area for the EGX-600 is 24" x 16" and 16" x 12" for the EGX-400. Both have a Z axis height of 1.57".

- Digital AC Servo brushless motors on all axes for unmatched precision
- 30,000 rpm spindle for higher torque and less vibration
- 2D and 3D Engraving
- 2 MB data re-plot buffer
- Sequence I/O control for networking
- Engraving software included



Call for Price!

EGX-400
LIST ~~\$9,995~~

EGX-600
LIST ~~\$11,995~~

EGX-360 Rotary Gift Engraver

The Roland EGX-360 boosts profits for gift engravers, trophy shops and jewelry retailers. The state-of-the-art desktop device produces everything from gifts, jewelry and awards to ADA signs and rhinestone decorated apparel. It virtually eliminates the need to outsource hundreds of jobs, delivering professional results with ultra-fast turnaround times.

- Personalize jewelry, gifts, awards and signs
- Engrave cylindrical objects made of glass and metal
- Engraves rings (inside & out) using the optional ring attachment
- Engrave flat and curved surfaces
- Maximum table size: 12 x 9.1 in. (305 x 230 mm)
- Maximum vise opening: 18 in. (457.2 mm)
- Maximum diameter supported: 8 in. (203.2 mm)
- USB port, cable and software included

Call for Price!

EGX-360
LIST ~~\$17,995~~





www.sfsupplies.com

Flexi 10



INDEX

DIGITAL MEDIA	5
SIGN VINYL	45
VINYL AND WRAP SUPPLIES	59
WIDE FORMAT EQUIPMENT	73
VINYL CUTTERS	87
ENGRAVERS	95
SOFTWARE	97
Sign Cutting & Printing.....	98-99
Clip Art	100-103
SUBSTRATES	105
BANNER	127
SIGN DISPLAY	139
TAPES & ADHESIVES	145
PAINT	153
NEON SUPPLIES & EQUIPMENT	167
TRANSFORMERS	207
LED SYSTEMS	229
LIGHTING & ELECTRIC	243
SIGN EXTRUSION	267
LETTER & ACCESSORIES	277
MOUNTING HARDWARE	281
EQUIPMENT & SHOP TOOLS	293

Sign Cutting & Printing



Flexi10



Available for Windows or Mac platform

FlexiFAMILY 10 sets a new industry standard with robust features that maximize production. Flexi excels as a one-stop software solution with a wealth of industry-specific design tools, easy-to-use interface and thousands of drivers to run your cutters, printers and hybrids. FlexiFAMILY 10... the leading software for sign making!

Some of the new features:

- New USB dongle to work with newer computers
- Improved Cut/Plot Dialogue Window
- Improved Optimize Cutting Order
- Nesting per vinyl color
- Make Transparent for non-RGB bitmaps
- Improved support of Adobe bitmap filters for CS4 and CS5.
- Ink estimation tool

The FlexiFAMILY offers a full line of five different products for professional sign making. Whether you're looking for a simple package for text layout and vinyl cutting, high production features with cutting and printing tools or something in between, SAI has a software solution for you!

FlexiSIGN-PRO™

LIST ~~\$4,295~~

The SAI flagship product, offers the total solution for any Sign Making business. With genuine Adobe® PostScript® 3 RIP engine, ICC profile support and built-in direct drivers, FlexiSIGN-PRO offers a complete set of design, cutting, RIPing and printing tools for maximum productivity.

FlexiEXPERT™

LIST ~~\$2,495~~

The package for the professional sign maker who requires advanced vinyl cutting and bitmap editing tools, without color-printing output. FlexiEXPERT includes full design, text serialization and color tracing features, as well as job estimating for accurate project management and design templates for faster production.

FlexiSIGN™

LIST ~~\$1,695~~

The mid-level Sign Making package provides exceptional tools to produce high-quality signage without a large initial investment. In addition to design, vinyl cutting, scanning and tracing capabilities, FlexiSIGN also includes Job Statistics and Text Styles for enhanced performance.

FlexiLETTER™

LIST ~~\$995~~

The entry-level layout and cutting package, features file import/export, full text manipulation and direct drivers for the industry's most popular vinyl cutters.

FlexiDESIGNER™

LIST ~~\$1,295~~

A program you can use as a second, design-only station. Get all the design, layout and image editing features of FlexiSIGN-PRO, as well as file preparation for output on another Flexi Family station, without the full price investment.



photoPRINT10

PhotoPRINT™ FAMILY

MORE THAN JUST A RIP. As technology moves forward, SA International brings you a new era in color management. Progressing along with the large format industry, PhotoPRINT™ 10 is designed to help your productivity ascend to new heights—while maintaining SAI's signature ease-of-use interface.

LIST ~~\$4,295~~

PhotoPRINT SERVER-PRO™

The complete client-server RIP solution package includes extended capabilities and cost-saving features. Additional features include an EDITOR station for layout and design and Color Profiler for output profile creation and editing.

PhotoPRINT SERVER™

LIST ~~\$3,495~~

The client-server RIP solution for networks and large production environments, featuring productivity tools such as Job Priority, Page Nesting and Job Nesting. These tools will make workflow to multiple printers generate accurate and consistent results in any volume.

PhotoPRINT DX™

LIST ~~\$1,595~~

An unparalleled layout package with design capabilities for text, shapes and effects, combined with the versatility to RIP and print to two devices simultaneously. The design and output of Print & Cut decals is straightforward and accurate with this integrated solution. Windows and Mac.

PhotoPRINT SE™

LIST ~~\$995~~

A RIP solution with the fundamentals for the single-workstation environment. Send jobs to RIP and print directly from popular design applications such as Adobe Photoshop® and Illustrator®, QuarkXPress®, CorelDRAW®, and CAD/AEC/GIS engineering solutions. Windows and Mac.

Its always best to upgrade to the latest version of your software. There are always lots of new features, product enhancements & technical fixes. We always sell software at discounted prices.

Please call us today for pricing on full versions or upgrade packages!

Sign Cutting & Printing

SignLab Version 9, **New!**

Not just a collection of new features, it is an enhanced way of doing things for Signmakers. New application plug-ins from often-used design applications, such as Corel, Illustrator and PhotoShop ensure quick, easy and error-proof ways that Signmakers can work with files and applications of all types during the design stage. A similar type interface with Visual Production Manager offers a seamless and centrally controlled production hub for all print, cut, print and cut jobs not only from SignLab but also these popular design applications. It's all about combining the strengths of all your design applications and enhancing them within SignLab.



SignLab for VersaWorks™ Edition

Specifically designed for sign makers using Roland VersaWorks™, you can send print, print and cut jobs to your Roland™ printers and Print and Cut devices. SignLab for VersaWorks™ is essentially an unmatched design and production front-end that sends jobs seamlessly to the VersaWorks™ RIP

SignLab DesignPro

LIST ~~\$1,000~~

A complete stand-alone, sign making-specific design station. Great for existing SignLab users if you want to add a design-only workstation to your shop or for sign makers using other sign making software or design software. Designer gives you the drawing and bitmap/vector editing tools you need to create high-value, quality signage.

SignLab CutPro

LIST ~~\$1,000~~

The ultimate vinyl cutting design and production sign software. SignLab CutPro is feature rich in text composition, design, layout and production tools for the signmaker looking to create vinyl cut signage. Choose from hundreds of cutter drivers to install the one that you require and instantly have a complete vinyl cutting design and production workstation.

SignLab Vinyl

LIST ~~\$1,600~~

SignLab Vinyl Software that addresses all design and production requirements for vinyl cutting workstations. Includes support for all the latest and legacy vinyl cutters used by most signshops today. Streamline your design and production workflow with all of the standard design, layout, and text composition tools required for signmaking. Run multiple cutters simultaneously from a single work station.

SignLab VinylPro

LIST ~~\$2,400~~

An all-inclusive vinyl cut signage design and production software product but also supports the design of full color graphics that may be sourced out for wide format digitally printed signs. All the great tools included within SignLab Vinyl plus a complete feature set of advanced, yet easy to use color design tools required for large format printing or print and cut signs and graphics.

SignLab Print & Cut

LIST ~~\$3,700~~

The professional signmakers choice for every day design and production of digitally printed, vinyl cut, print/cut signs and graphics. While it enables today's signmaker to design and produce every job in a single software package its true strength is in the integration of many other widely used design applications such as Corel, Illustrator and PhotoShop. SignLab Print and Cut is anchored by Visual Production Manager a simultaneous, multiple job queue that supports most printers, cutters and hybrid print/cut devices available today.



ProductionHouse is for running a "print factory." It is easy to use with flexible, powerful, professional tools that allow you to control your production workflow, deliver superior color quality and reduce production costs.

LIST ~~\$4,995~~



PosterShop is the solution for professional printers. Easily build highly efficient Print-only and Print-and-Cut workflows for a wide array of supported devices while delivering superior output quality to your customers.

LIST ~~\$3,295~~



RIPCenter is perfect to help you get started in wide format printing. With Native PDF, PS and Raster image processing and easy to set up automated workflows; you can reliably and efficiently produce high quality output.

LIST ~~\$1,695~~



Please call for pricing on full versions or upgrade packages! Special pricing for competitive upgrade

Clip Art

Vector Graphics



Mega Collection

Created by sign-makers organized on a CD-Rom disk (.ai and .eps file formats), and an 8.5 x 11, catalog, printed on heavy card stock with durable laminated covers. Every Vector Art image is composed of a perfect, closed vector path. There are no open paths, crossed or intersecting lines in any Vector Art image.

Each volume contains 5000+ images.

Mega Collection

ITEM NO. CDCAVAMC

Mega 2 Collection

ITEM NO. CDCAVAMC2

Mega 3 Collection

ITEM NO. CDCAVAMC3

Tomm Toons Vol. 1

Over 250 pieces of clip art, ready to use on your next sign layout: cartoons, vehicles, holiday themes, display text and more. The ready-to-cut vector images are each provided in JPG, EPS and AI formats.

ITEM NO. CDCATT-1

DIGITALDESIGNWARE

International Safety Signs

Hundreds of safety signs, digitized from international standard.

ITEM NO. CDCADDISS

Sign & Design Concepts

30 full-colored and pre-designed layouts for the creation and production of customized signs and letterings.

ITEM NO. CDCADSDC

Sign & Design Graphics

Useful design-elements like frames, banners, sign templates and much more.

ITEM NO. CDCADSDG

Vehicle Templates

DIGITALDESIGNWARE

Car'n Truck/Pro Vehicle Outlines 2011 Basic

Perfect for vehicle lettering and wraps!

The biggest vehicle template library ever! Now over 44,000 templates are available to vehicle graphics experts worldwide!

ITEM NO. CDCADDCTPVO

Car'n Truck/Pro Vehicle Outlines 2011 3D

In addition to the above it comes with software converts conventional designs into highend 3D presentation videos and renderings.. Show your client how the finished wrap would look.

ITEM NO. CDCADDCTPVO3D

Vector Vehicle Graphics

DIGITALDESIGNWARE

Hot Flames

Hot Flames Vol. 1

300 Classic and brand new hot flame designs for cars, trucks, hot rodder, race-cars, jet skis, helmets etc.

ITEM NO. CDCADDHF1

Hot Flames Vol. 2

225 brand-new vehicle graphics for cars, trucks, boats, jet skis etc.

ITEM NO. CDCADDHF2

Flaming Animals

100 unique animal flames. A new collection of Vehicle Graphics with 100 high-class vector images; all vinyl-ready.

ITEM NO. CDCADDFA

Motorsports

The new Motorsports Collection contains 50 high-class vector motor-sport designs.

ITEM NO. CDCADDMS

Power Edition

More than 1000 design elements for cars, trucks, boats, jet skis etc.

ITEM NO. CDCADDPE

Race Pack

400 brand new images of the real racing stuff, including checkered flags, race numbers and much more.

ITEM NO. CDCADDRP

Street Race Graphics

Street Race Graphics Vol. 1

210 brand-new vehicle graphics for cars, trucks, boats, jet skis etc.

ITEM NO. CDCADDSRG1

Street Race Graphics Vol. 2

151 brand-new vehicle graphics for cars, trucks, boats, jet skis etc.

ITEM NO. CDCADDSRG2

Tribals

Tribals Vol. 1

151 vehicle graphics

ITEM NO. CDCADDT1

Tribals Vol. 2

179 brand-new vehicle graphics.

ITEM NO. CDCADDT2

Tribals Vol. 3

179 brand-new vehicle graphics.

ITEM NO. CDCADDT3

Vector Vehicle Graphics

Vehicle graphics just don't get any better than this!
600 fully vectorized vehicle graphics ready to cut on your equipment.



The Platinum Edition comes complete with a full size (8.5 X11) full-color, bound book showing every graphic on a real car. 600 beautifully designed professional grade graphics are expertly vectorized and ready for smooth, quick cutting. Included are .eps and .ai formats.

ITEM NO. CDCAAGPE



Millennium Edition



The Millennium Edition Gold contains 600 unique vectors that can be used as cut path for a partial wrap or simply as a clipping mask. Though brother to the Platinum Edition you will not find duplicates from one to the next. Millennium Edition also comes with a full color sales reference book.

ITEM NO. CDCAAGMEG

Print and Cut Graphics



Combining colorful polished surfaces with chrome effects in .pdf format. Its as easy as open, scale, print/cut. With 30 different shapes and 9 unique print effects there are a total of 270 files ready to print and cut! Also included on this DVD are transparent .tiff format graphics to be used as a design element in a full body wrap. The .tiff versions also come with an optional drop shadow or a simple beveled transparency of the graphics.

ITEM NO. CDCAAGDC

DIGITALDESIGNWARE

FX Flames

525 high resolution vehicle graphics, ready for print and cut.

ITEM NO. CDCADDPWFX



3D Print & Cut Magic, 3D METAL MACHINE



3D Metal Machine is a print and cut ready title. These files come in .tiff and .jpg file format with .eps cut contours. Using this title is as easy as scale, print and cut. Included in the package is a full color catalog showing each graphic and its file name.

ITEM NO. CDCAAG3DMM



Print Craft Sign Blanks make it very quick and easy to build signs.

Simply add any logos and text that you would like and you are ready to output a professional looking sign. Comes with an .eps cut contour that can be used as a cut path or a clipping mask allowing you to incorporate the sign into a larger design.

ITEM NO. CDCAAGSB



Photoshop Training



Pro Designer

The first ever Photoshop training for vinyl. Having many uses for many industries, Photoshop is a vast program. Aurora has cut down to the nitty-gritty and shows just the tools most widely used in this industry. In an easy to understand way, you will learn a whole list of topics: 3-D bevel and emboss, changing colors, shadowing, filling text, even how to design a full wrap using a template in Photoshop.

- 1 hour 45 minutes
- Windows Media File
- Photoshop Fills Droplet

ITEM NO. CDCAAGPD



Pro Designer 2

Advanced Photoshop Training For Vinyl takes designing to a new level. As you know Adobe Photoshop is a powerful program, Pro Designer 2 will show you how to use that power to create and manipulate images in ways you never thought possible. Will also show how to create your own photorealistic template. You'll learn all the steps it takes to create a template from anything under the sun. Pro Designer 2 is for those who have a good basic knowledge of Photoshop like you gained from the original Pro Designer.

ITEM NO. CDCAAGPD2

We have all other Aurora great products at discount prices.

Clip Art

Print Fills



Print Craft Pro Fills were designed with vehicle graphics and truck door lettering in mind. While these fills are not tileable they include many things that you can't get in a tileable package. Animal hides, sky scenes, lightning, you name it! The Print Craft Pro Fills come in .jpg file format with the available hardware in transparent .tiff format. 329 images total.

- 16" x 50" @ 72 dpi!

ITEM NO. CDCAAGPC1



Print Craft Pro Fills 2 are the second volume in the Print Craft series. Suited best for vehicle graphics, signs and banners. This title covers a wide spectrum of imaging including beautiful wood fills, flags, camo and much more. 423 images total.

- 18" x 50" @ 72 dpi!

ITEM NO. CDCAAGPC2



Tileable Fills!

Monster Wrap Fills are perfect for any scale of printing. These hi resolution images are 16" x 16" @ 300 dpi. When printing at 72 dpi these monsters are a whopping 64" x 64"! While already huge they will also tile seamlessly to any scale while still maintaining an excellent print quality. Simply copy and paste them next to each other until you reach your desired scale.

- 16" x 16" @ 300 dpi and seamlessly tileable!
- 257 images total.

ITEM NO. CDCAAGMW



Includes three volumes - Print Craft Pro, Print Craft Pro 2 and Print Craft Sign Blanks, all on one DVD.

ITEM NO. CDCAAGPCS



Tileable Fills!

Tile Master Fills are the second addition to our seamlessly tileable fills. Use them to fill text or tile them out to be as large as you need.

- 30" x 30" @ 100 dpi and seamlessly tileable!
- 150 images total

ITEM NO. CDCAAGTMF

DIGITALDESIGNWARE

Tiles & Textures

This collection comes with hundreds of high resolution and seamless tiles for your individual designs.



ITEM NO. CDCADDPWTT

Wrap Design Elements



Add any of the transparent .tiff flame images to your work and watch it sizzle!

Digital Firestorm flames are the most realistic flames on the market. Choose from side flames, rocker panel flames, hood flames & more. Providing them in transparent .tiff format allows you to float them over the top of any background and get a real look.



- 127 images total
- Very large scale

ITEM NO. CDCAAGDFS



Backgrounds and design elements for wrapping vehicles.

Including transparent .tiff design elements like barbed wire and lightning that you can simply float over your design. While this title requires Photoshop it also provides you with the capability to come up with thousands of different designs. With a creation scale of 8.1" x 21" @ 720 DPI These make great design elements for any scale of printing.

- 285 images total
- 81" x 210" @ 72 dpi

ITEM NO. CDCAAGWW

DIGITALDESIGNWARE

Print'n Wrap — Ghost Flames

25 different flame designs. Available in 5 popular colors. These flames have transparent fading colors which will fit perfectly on any vehicle body color.



ITEM NO. CDCADDPWGF

Wild Fire

An extensive new collection of print ready realistic flames. Ideal for designing flames on the sides, hoods and roofs of any vehicle.



ITEM NO. CDCADDPWWF

Wrap Design



Wrapture Full Body Wraps Volume 1 includes the largest digitally created scene files available. With a creation scale of 88" X 236" there are few jobs too big for the Wrapture Series. Provided in .jpg file format. Having created all of the designs at full scale using 3-D technology you will find no .jpg artifact or other defects in this beautiful piece of work.

- 72 images total,
- 88" x 236" @ 72 dpi

ITEM NO. CDCAAGWFBW1



Wrapture Full Body Wraps Volume 2 is 3-D to the extreme! Including huge abstract back grounds that can be incorporated into any design or advertisement. They can be used as is or modified to be a half wrap or simply used as a fill.

- 72 images total,
- 88" x 236" @ 72 dpi

ITEM NO. CDCAAGWFBW2

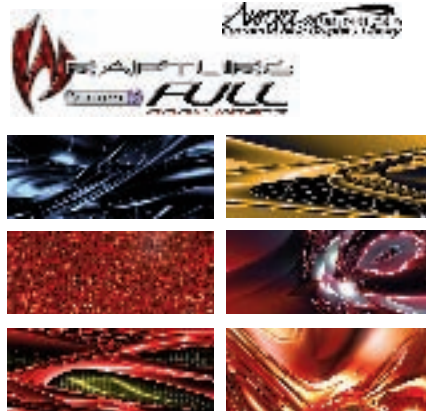

Wrapture Full body Wraps Volume 3 is the wildest of the bunch. With inlays of several different types these files are ready to go or easily changed. You make the sign and let Wrapture get their attention.

- 72 images total,
- 88" x 236" @ 72 dpi

ITEM NO. CDCAAGWFBW3



Wrapture Half Body Wraps Volume 1 is a revolutionary way to get the same effects of a full wrap while using lots less vinyl and avoiding the really difficult spots. You know what that means, more jobs done in less time and cheaper for everyone! This title is also perfect for shops just getting in to wraps. These files are all supplied in .tiff format each with a separate cut contour in .eps file format.

- 70 images total
- 200" long @ 72 dpi
- .tiff and .eps formats

ITEM NO. CDCAAGWHBW1

DIGITALDESIGNWARE

Full Wrap Graphics

This is a professional collection of high resolution, large format backgrounds for your vehicle wraps.



ITEM NO. CDCADDPWFVG

Full Wrap Graphics 2

- 27 unique designs
- 750 dpi on 24" x 12"

ITEM NO. CDCADDPWFVG2



Full Wrap Graphics 3

- 27 unique designs
- 750 dpi on 24" x 12"

ITEM NO. CDCADDPWFVG3



Skylines

These volume contains an fantastic mix of 27 skyline designs of North American cities, useful as background for vehicle wraps. Perfect for large format printing

- 750 dpi on 24" x 12"





www.sfsupplies.com

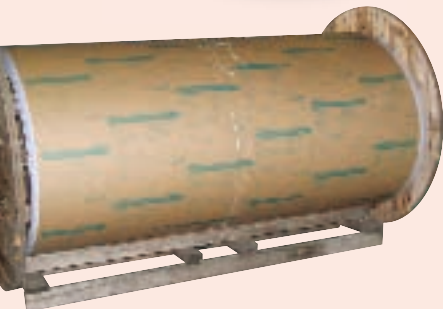

INDEX

DIGITAL MEDIA	5
SIGN VINYL	45
VINYL AND WRAP SUPPLIES	59
WIDE FORMAT EQUIPMENT	73
VINYL CUTTERS	87
ENGRAVERS	95
SOFTWARE	97
SUBSTRATES	105
Aluminum.....	106-109
Plastic.....	110-115
Foam PVC.....	116
Laminated Panels	117-120
Foam Board	121-122
Currogated Plastic Sheets	123
Precision Boards.....	124
Flex Face	125
Magnetic Sheets.....	126
BANNER	127
SIGN DISPLAY	139
TAPES & ADHESIVES	145
PAINT	153
NEON SUPPLIES & EQUIPMENT	167
TRANSFORMERS	207
LED SYSTEMS	229
LIGHTING & ELECTRIC	243
SIGN EXTRUSION	267
LETTER & ACCESSORIES	277
MOUNTING HARDWARE	281
EQUIPMENT & SHOP TOOLS	293

Aluminum

S&F is the Premier Supplier of Painted Aluminum Sheets in the Industry

We stock every possible color gauge & size available

Plus we cut & bend to customers' specification

Painted Aluminum sheets is one of the most important materials to the sign industry. The fact that it doesn't rust makes it a first choice for durable signage. It is easily formed in metal bending equipment, easily mig-welded, and very easily cut, drilled, and smoothed with standard shop tools. It is used in a variety of sheet thicknesses for sign panels, channel letter and moldings.

S&F stocks an array of gauges, widths, finishes for every requirement. No other sign distributor offers such an extensive selection of painted aluminum flat sheet and coil. S&F can supply you with virtually any specification, color or finish that you require. For this reason, we have emerged as the preferred supplier to sign & awning manufacturers through out the east coast.

S&F delivers exceptional service with personal attention to each individual order. Our in-house inventory gives us the ability to give you a quick turn-around; our worldwide network of reliable aluminum mills gives us the ability to bring nearly any aluminum product into our plant when you need it. This allows us to process your orders with the speed you demand.

All your aluminum sheeting orders can be cardboarded & taped for transit and delivery per request.



We cut and bend aluminum sheets to your specifications. We can also provide you with custom molding and siding.



All of our aluminum sheets are 2 coated, baked on polyester finish stain resistant, wax free and ready to go.



From coils...



to sheeting...



to stocking...



to delivery.

See your sales rep today about bulk orders, special volume discounts & many other benefits

Aluminum

Aluminum Sheet Color Chart

Painted Aluminum



Matte White (unmasked)



Gloss White

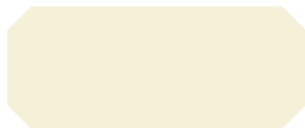

Ivory



Yellow



Bright Yellow



Caution/Safety Yellow



Orange



Bright Red



Red



Burgundy



Purple



Pepsi Blue



Chevron Blue



Heron Blue



Bright Green



Green



Mocha Tan



Brown



Bronze

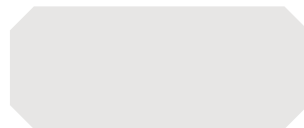

Light Gray



Medium Gray



Dark Gray



Charcoal (unmasked)



Gloss Black



Matte Black

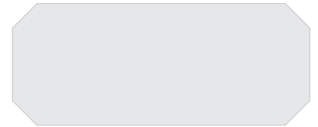

Mill Finish



Diamond Plate

Anodized Aluminum



Clear Mirror



Gold Mirror

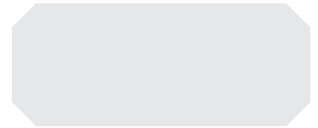

Clear Anodized



Gold Anodized



Brushed Clear



Brushed Gold

Colors are printed representations and may not match the actual product colors.

For an accurate color swatch book, please contact your S&F sales rep

Aluminum

Aluminum Sheet Availability Chart

4' x 8' - 4' x 10'

COLOR	THICKNESS
Bright Diamond Plate	.040, .063
Bright Green	.040
Bright Red	.040
Bright Yellow	.040
Bronze	.024, .032, .040, .063
Brown	.040
Burgundy	.040
Caution/Safety Yellow	.040
Charcoal (No mask)	.040
Chevron Blue	.040
Clear Mirror	.024, .032, .040
Dark Gray	.040
Gloss Black	.024, .032, .040, .063
Gloss White	.024, .032, .040, .050, .063, .080, .090
Gold Mirror	.024, .032, .040
Green	.024, .032, .040
Heron Blue	.024, .032, .040
Ivory	.024, .032, .040
Light Gray	.040
Matte Black	.024, .032, .040, .050, .063
Matte White (No mask)	.024, .032, .040, .063
Mill Finish	.024, .032, .040, .050, .063, .080, .090, .125, .190, .250
Mocha Tan	.040
Orange	.040
Pepsi-Blue	.040
Purple	.040
Red	.024, .032, .040
Yellow	.024, .032, .040
Clear Mirror	.024, .032, .040
Clear Anodized	.024, .032, .040, .063, .080, .125
Gold Anodized	.032, .040
Brushed Clear	.032, .040, .063, .080
Brushed Gold	.032, .040

3' x 8' - 3' x 10'

COLOR	THICKNESS
Gloss White	.020, .032, .040

5' x 8' - 5' x 10'

COLOR	THICKNESS
Gloss White	.040, .063
Mill Finish	.040, .063, .080, 1/8"

S&F Aluminum Item No. System

"A" for Aluminum Size Gauge Color

A 48 40 BR

Example = 4' x 8' Brown Aluminum Sheet, .040 Gauge

Gauge:

.020 = 20	.040 = 40	.080 = 80	.187 = 36
.024 = 24	.050 = 50	.090 = 90	.250 = 14
.032 = 32	.063 = 63	.125 = 18	.500 = 12

Size:

3' x 8' = 38	4' x 8' = 48	5' x 8' = 58
3' x 10' = 310	4' x 10' = 410	5' x 10' = 510

Color:

Bright Green = BRGR	Clear Anodized = CA	Light Gray = LG
Bright Red = BRR	Clear Mirror = CM	Matte Black = MBK
Bright Yellow = BRYE	Dark Gray = DGY	Matte White* = BZ,MB
Bronze = BZ	Diamond Plate = BRDP	Medium Gray = MG
Brown = BR	Gloss Black = GBK	Mill Finish = MF
Brushed Clear = CS	Gloss White = W	Mocha Tan = T
Brushed Gold = GS	Gold Anodized = GA	Orange = O
Burgundy = BU	Gold Mirror = GM	Pepsi Blue = PB
Caution/Safety Yellow = CY	Gold Painted = GP	Purple = PU
Charcoal* = MG	Green = GR	Red = R
Chevron Blue = CB	Heron Blue = HB	Yellow = Y
	Ivory = I	

* No masking

See our Sign Extrusion section starting page 269 in this catalog for all your aluminum tubings, brackets, centers etc.



Galvanized Sheets



ITEM NO.	SIZE	GAUGE
AG41022	4x10	22ga
AG4822	4x8	22ga

Other thicknesses available as special order

Aluminum

MAXX-BRITE Aluminum Coil

MAXX-Brite® is the most reflective channel letter coil available, and eliminates the need for additional paints, films, L.E.D. or neon!



ITEM NO.	SIZE	GAUGE	COLOR
MAXBR-4.340WHT	4.3" x 270'	.040	White
MAXBR-WHT	5.3" x 270'	.040	White
MAXBR-BZ	5.3" x 270'	.040	Bronze
MAXBR-GLBK	5.3" x 270'	.040	Gloss Black
MAXBR-MBK	5.3" x 270'	.040	Matte Black
MAXBR-HB	5.3" x 270'	.040	Heron Blue
MAXBR-IVGR	5.3" x 270'	.040	Ivy Green
MAXBR-IV	5.3" x 270'	.040	Ivory
MAXBR-RED	5.3" x 270'	.040	Red
MAXBR-YEL	5.3" x 270'	.040	Yellow
MAXCO-MF	5.3" x 270'	.040	Mill Finish

Aluminum Blanks

All stock blanks are white/white with masking and radius corners of 3/4".



ITEM NO.	SIZE	GAUGE	ITEM NO.	SIZE	GAUGE
AB121840R	12" x 18"	.040	AB242463R	24" x 24"	.063
AB121863R	12" x 18"	.063	AB242480R	24" x 24"	.080
AB121880R	12" x 18"	.080	AB243640R	24" x 36"	.040
AB182440R	18" x 24"	.040	AB243663R	24" x 36"	.063
AB182463R	18" x 24"	.063	AB243680R	24" x 36"	.080
AB182480R	18" x 24"	.080	AB62440R*	6" x 24"	.040
AB242440R	24" x 24"	.040			*square corners

**Any size or color available as special order
Please call for pricing**

Perforated Metal

All perforated metal are special order only

Perforated metal has many applications, including screening, ventilation, protection, or decoration. A wide selection of hole sizes, gauges, shapes and materials are available.

- Lightweight
- Versatile
- Attractive
- Economical
- Easily customized
- Wide range of open area
- Suitable for decorative applications
- Stocked in a variety of hole patterns, gauges, and materials



Perforated Round Hole Pattern

Perforated round hole pattern is one of our most popular products. It is versatile, economical, and comes in a broad range of hole patterns, sizes, gauges, and materials.



Perforated Round Display Panel - Perf-Panl™

Perf-Panl™ is an ideal choice as a display board or utility divider and gives you the advantages of wire hook board with the strength of steel.

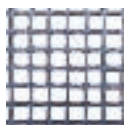

Perforated Square Hole Pattern

Perforated with a square hole can provide a greater percent open area than round holes. It is versatile, economical, and available in a variety of materials, gauges, and hole sizes.



Perforated Slotted Hole Pattern

Perforated with a slot hole pattern has elongated holes with rounded or square ends and straight parallel sides.

Perforated Hexagonal Hole Pattern

Hexagonal Perforated metal is ideally suited for a wide range of architectural design applications. Hexagonal perforated metal is available in various materials and the majority of the sheets are between 16 and 22 gauge.

Perforated Decorative Pattern

Decorative Perforated metal is ideally suited for a wide range of architectural design applications. Decorative perforated metal is available in various materials and the majority of the sheets are between 16 and 24 gauge.

Plastic

S&F offers the most complete line of plastic sheets in the industry!

Every color, size & thickness from leading manufacturers In stock!



Are you looking for...
 Standard sheet sizes?
 Over-size sheets?
 Hard-to-find color or thickness?
Look no further than S&F
 Master Distributors of Plastic Sheets



Plexiglas®

Altuglas International's extensive product line is used in many markets and applications worldwide. From standard to very high impact PMMA, Plexiglas® acrylic resin can be used in applications from lighting to fencing, spas to point of purchase.

CHEMCAST

35 Standard Colors, carefully matched to market specifications. More than 85 custom colors including opaques, transluents, fluorescents, marbles, pearls colors.

Plastiglas has two factories capable of producing the complex diversity of products normally associated with cell casting, including Clears, Colors, Fluorescents, Pearlescents, Marble Patterns in varied colors, and P-95 pattern sheet.

PLASKOLITE, INC. OPTIX®

Plaskolite offers a full line of acrylic sheet products that are appropriate for a number of industrial applications, including point-of-purchase displays, sign fabrication, automotive accessories, picture framing and skylight fabrication.

For the sign fabricating industry, Plaskolite offers Sign Grade Optix Acrylic and Duraplex impact modified acrylic in roll stock and oversized flat sheet sizes.

Roll Stock provides unlimited lengths, reducing the number of seams and joints in a large sign face. It also provides efficient inventory space utilization and better total sheet usage.

Sign Market Sheet Available in:

SG — OPTIX® General Purpose Acrylic

SG05 — DURAPLEX® Medium Impact Modified Acrylic

SG10 — DURAPLEX® High Impact Modified Acrylic

Sheet Cutting Service

We custom cut plastic sheets to your specification.
 No job too small or too large to handle.



Added Service at S&F...

In addition to our standard cutting, we now handle large volume cutting on our newly acquired CNC Panel Saw cutting system. Cuts are 100% accurate. Ideal for your most complex jobs, i.e. POP, silkscreen etc.



Acrylic Sheet Cross Color Reference Chart

PLEXIGLAS NUMBER	CHEMCAST NUMBER	CHEMCAST FACTORY NUMBER	CYRO COLOR FAMILY TYPE
7328	7328	Z-25	015-2 White TL
2447	2447	Z-26	020-4 White TL
2146	2146	L-020	047-2 IVORY TL
7420	7420	Z-3	048-2 White TL
2250	N/A	N/A	049-3 White TL
2067	2067	Z-01	051-6 White TL
2159	N/A	N/A	052-6 White TL
7138	7138	Z-2	054-3 White TL
2332	N/A	N/A	063-3 White TL
5542	N/A	N/A	070-4 White TL
7508	7508	Z-6	076-0 White TL
2075	N/A	N/A	096-7 White TL
2017	N/A	N/A	NIO-219 White TL
2064	2064	H-26	103-2 Gray TL
2074	2074	H-074	104-1 Gray TL
2256	N/A	N/A	120-5 White TL
2349	N/A	N/A	121-0 Gray TL
2404	2404	H-11	126-4 Bronze TL
2412	2412	H-083	131-2 Bronze TL
2022	N/A	N/A	137-0 Black TL
2530	2530	L-123	
2537	N/A	N/A	140-3 Gray TL
2514	2514	H-043	141-5 Gray TL
2538	2538	H-070	142-1 Gray TL
2094	N/A	N/A	143-4 Gray TL
2515	2515	H-042	144-7 Gray TL
2539	2539	N/A	145-5 Bronze TL
2540	N/A	N/A	146-7 Bronze TL
2545	N/A	N/A	147-0 Bronze TL
2210	N/A	N/A	158-0 Gray TL
1573	N/A	N/A	176-0 Gray TL
2348	N/A	N/A	189-0 Gray TL
2025	2025	F-135	199-0 Black TL
2607	N/A	N/A	1104-0 Gray TL
2347	N/A	2347	1106-0 Gray TL
2348	N/A	N/A	1107-0 Gray 0
5427	N/A	N/A	1108-0 Gray TL
2236	N/A	N/A	113-3 Gray TL
2943	N/A	N/A	1116-4 Gray TL
3028	N/A	N/A	CH1-244 Gray TL
3001	N/A	N/A	CH1-305 Gray TL
3028-A	N/A	N/A	CH1-306 Gray TL
2662	N/A	N/A	202-0 Red TL
2157	2157	L-136	205-0 Red TL
2115	N/A	N/A	207-0 Red TL
2415	2415	L-137	209-0 Red TL

PLEXIGLAS NUMBER	CHEMCAST NUMBER	CHEMCAST FACTORY NUMBER	CYRO COLOR FAMILY TYPE
2444	N/A	N/A	210-0 Red TL
2283	2283	L-134	211-1 Red TL
2085	L116	N/A	216-4 FL Red TL
2262	N/A	N/A	217-0 Red TL
2363	N/A	N/A	218-0 Red TL
2240	N/A	N/A	231-0 Maroon TL
2461	N/A	N/A	248-0 Red TL
2423	2423	N/A	257-0 Red TL
2226	N/A	N/A	261-2 Red TL
2380	N/A	N/A	262-0 RUST TL
2793	2793	L-135	278-0 Red TL
2129	N/A	N/A	282-1 Red TL
2991	N/A	N/A	286-0 Pink TL
2483	N/A	N/A	293-0 Burgundy
2240	N/A	N/A	2100-0 Maroon TL
2483	N/A	N/A	2106-0 Maroon TL
2945	N/A	N/A	2107-0 Red TL
2483	N/A	N/A	2109-0 Maroon TL
2330	N/A	N/A	AT2-011 Coral TL
3080	N/A	N/A	AT2-151 Rusty TL
2119	2119	L-154	303-0 Orange TL
2370	2370	H-25	311-1 Bronze TL
2418	2418	L-220	324-2 Brown TL
2143	N/A	N/A	328-0 Orange TL
2564	N/A	N/A	338-1 Orange TL
2630	N/A	N/A	364-0 Brown TL
2016	2016	L-049	406-1 Yellow TL
2037	2037	L-167	407-2 Yellow TL
2451	N/A	N/A	408-5 Amber TL
2086	N/A	N/A	411-5 FL Yellow
2268	N/A	N/A	413-1 Yellow TL
2172	N/A	N/A	420-4 Amber TL
2242	N/A	N/A	422-1 Amber TL
2325	N/A	N/A	424-3 Yellow TL
2208	2208	L-045	430-7 Yellow TL
2465	N/A	N/A	432-2 Yellow TL
2422	2422	L-151	436-4 Amber TL
2558	N/A	N/A	441-6 Amber TL
2030	2030	L-063	506-0 Green TL
2108	2108	L-061	507-0 Green TL
2047	N/A	N/A	518-0 Green TL
2024	N/A	N/A	519-0 Green TL
2130	N/A	N/A	522-2 Green TL
2215	N/A	N/A	534-0 Green TL
2092	2092	L-054	545-2 Green TL
2082	N/A	N/A	546-7 Green TL

PLEXIGLAS NUMBER	CHEMCAST NUMBER	CHEMCAST FACTORY NUMBER	CYRO COLOR FAMILY TYPE
2324	2324	L-065	552-1 Aqua TL
2730	N/A	N/A	594-0 Green TL
2586	N/A	N/A	595-0 Mint TL
2114	2114	L-081	605-0 Blue TL
2050	2050	L-073	606-0 Blue TL
2051	2051	L-077	607-1 Blue TL
2329	N/A	N/A	613-0 Blue TL
2069	2069	L-189	625-5 Blue TL
2443	N/A	N/A	654-7 Aqua TL
2424	2424	N/A	668-0 Blue TL
2648	2648	N/A	6109-0 Blue TL
2534	N/A	N/A	6113-0 Blue TL
3287	N/A	N/A	702-0 Violet TL
4347	N/A	L-143	Gray Opaque
		L-024	Pink Opaque
		L-098	Violet Opaque
		L-037	Rust Opaque
		L-100	Mauve Opaque
		H-2	Gray Pastel
		Z-01	White Pastel
		C-010	Lt.Pink Pastel
		C-015	Rose Pastel
		C-067	Green Pastel
		C-022	Beige Pastel
		C-047	Yellow Pastel
		C-082	Blue Pastel
		L-116	Red Fluore 2085
		L-111	Green FluorescentTL
		L-032	Orange FluorescentTL
		L-089	Blue FluorescentTL
		L-043	Yellow FluorescentTL
		L-450	Gray Pearls
		L-412	Blue Pearls
		L-403	Pink Pearls
		L-402	Brown Pearls
		L-400	White Pearls
		L-401	Ivory Pearls
		M-058	Green Marbles
		M-082	Blue Marbles
		M-114	Chocol Marbles
		M-112	Tan Marbles
		M-120	Gray Marbles
		M-134	Char Gray Marbles
		L-026	Pink Mirror

Plastic

Plastic Sheet Availability Chart















1/8" - 1/4"

COLOR	1/8"	3/16"	1/4"	COLOR CODE	
	Amber 2422	4x8		2422	
	Black/White 3063-P95	4x8	4x8	3063	
	Black 2025	4x8, 6x8	4x8, 4x10, 5x8, 6x8, 6x10	2025	
	Matte Black 2025-P95	4x8	4x8	2025M	
	Blue 2050	4x8	4x8	2050	
	Blue 2051	4x8	4x8, 6x8	2051	
	Blue 2114	4x8	4x8, 4x10, 6x8, 6x10	2114	
	Blue 2648	4x8	4x8	2648	
	Bronze 2370	4x8	4x8	4x8	2370
	Bronze 2412	4x8	4x8	2412	
	Brown 2418	4x8	4x8	2418	
	Burgundy L-093/2483	4x8	4x8	093	
	Burgundy Translucent L-119	4x8		119	
	Clear Poly film	4x8, 4x10, 5x8, 6x8	4x8, 4x10, 4x12, 5x8, 5x10, 6x8, 6x10	4x8, 5x8, 4x10, 4x12, 5x8, 5x10, 6x8	CLPLM
	Clear Paper Mask	4x8	4x8, 5x8	4x8	CLPP
	Clear P95	4x8	4x8	4x8	CLP95
	Clear Non Glare	4x8			CLNG
	Glass Green 3030	4x8	4x8		3030
	Gold Mettalc 6371		4x8		6371
	Gray L-143/2347	4x8			143
	Gray 2074	4x8*	4x8	4x8	2074
	Green 2030	4x8	4x8		2030
	Green 2108	4x8	4x8, 6x8		2108
	Green/Aqua L-076	4x8*			076
	Ivory 2146	4x8	4x8, 4x10, 6x8, 6x10		2146
	Mirror Clear	4x8			CM
	Mirror Gold	4x8			GM
	Orange Fluorescent L-032	4x8*			032
	Orange 2119	4x8	4x8		2119
	Pink L-024	4x8			024
	Purple L-095	4x8			095

*custom order only

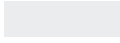
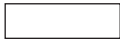
Plastic Sheet Availability Chart

1/8" - 1/4" - Continued

COLOR	1/8"	3/16"	1/4"	COLOR CODE
	Red 2157 4x8	4x8, 6x8		2157
	Red 2283 4x8	4x8, 4x10, 6x8		2283
	Red 2793 4x8	4x8, 4x10, 5x8 6x8, 6x10		2793
	Red Fluorescent L-116 4x8*			116
	Seafoam L-065/2324 4x8*			065
	SeeThru Mirror 4x8		4x8*	STM
	Silver Metallic L-454 4x8			454
	Turqua L-074/2308 4x8*			074
	Violet L-099 4x8			099
	White Matte 7328-P95 4x8*			7328
	White 2447 4x8	4x8, 4x10, 6x10		2447
	White 7328 4x8, 4x10, 5x8, 6x8	3x8, 3x10, 3x12, 4x8, 4x10, 4x12, 5x8, 5x10, 6x10, 6x12	4x8	7328
	White 7508 4x8	4x8		7508
	Yellow 2016 4x8	4x8		2016
	Yellow 2037 4x8, 4x10, 5x8, 6x8	4x8, 4x10, 5x8, 6x8, 6x10		2037
	Yellow 2465	4x8		2465

.060 - .100

COLOR	.060	.100
Black	4x6	
Clear Poly film	4x8	4x8
Clear Paper Mask	4x8	
Clear Non Glare	4x8	
White 7328	4x6, 4x8	

3/8" - 3/4"

COLOR	3/8"	1/2"	3/4"
Black 2025	4x8	4x8	
Clear Paper Mask	4x8, 4x10	4x8, 4x10, 5x8	4x8
White 7328	4x8	4x8	4x8

1" - 1-1/2"

COLOR	1"	1-1/4"	1-1/2"
Clear Paper Mask	4x8	4x8	4x8
White 7328	4x8		

*custom order only

S&F Plastic Item No. System

"PL" for Plastic Thickness Size Color
PL 18 48 2114

Example = 4' x 8' Blue Plastic Sheet, .1/8" Gauge

Thickness:	Size:	Color:
1/16" = 16	3' x 8' = 38	Color code is listed in the availability chart on this page.
3/32" = 100	3' x 10' = 310	
1/8" = 18	3' x 12' = 312	
1/4" = 14	4' x 8' = 48	
3/16" = 36	4' x 10' = 410	
3/8" = 38	4' x 12' = 412	
1/2" = 12	5' x 8' = 58	
3/4" = 34	5' x 10' = 510	
1" = 1	6' x 8' = 68	
1 1/4" = 114	6' x 10' = 610	
1 1/2" = 112	6' x 12' = 612	

Plastic

Polycarbonate Sheets

We have the largest available stock on PC sheets in clear & white for the sign industry. Whether it's sheets or reels, we have it for you.

Virtually unbreakable, Tuffak A sheet is 300-times stronger than single-strength glass, and significantly tougher than other transparent sheet materials of equal thickness. It's unlikely that Tuffak A sheet will break, shatter or chip when bombarded with thrown missiles such as rocks, bricks or bottles. Nor is it likely that this material will break when hammered, twisted or bent.

At the same time, Tuffak A polycarbonate sheet is light in weight, transmits 85% to 89% light in normal window thicknesses, and has good weatherability. UV-stabilized Tuffak A sheet has good resistance to solar exposure for five to seven years in moderate climate. Such exposure over a wide temperature range does not affect its impact strength.

Tuffak A polycarbonate sheet is supplied in colorless transparent sheet and in solar tints for heat and glare control. The material is available in standard sheet sizes ranging from 24" x 48" to 96" x 96" and 72" x 120", and in thicknesses from .060" to .500".

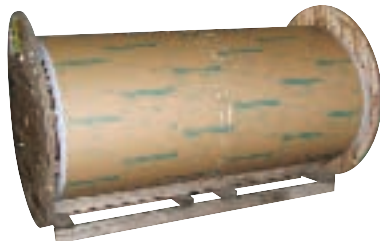

Clear Sheets

ITEM NO.	THICKNESS	SIZE
PCCLR48116S	1/16"	4' x 8'
PCCLR48100S	3/32"	4' x 8'
PCCLR4818S	1/8"	4' x 8'
PCCLR41018S	1/8"	4' x 10'
PCCLR4836S	3/16"	4' x 8'
PCCLR41036S	3/16"	4' x 10'
PCCLR4814S	1/4"	4' x 8'
PCCLR41014S	1/4"	4' x 10'
PCCLR48564S	5/64"	4' x 9'
PCCLR4838S	3/8"	4' x 8'
PCCLR4812S	1/2"	4' x 8'

Clear Reels

ITEM NO.	THICKNESS	ROLL WIDTH
PCCLR5236R	3/16"	52"
PCCLR7636R	3/16"	76"

"Sign White" Sheets

ITEM NO.	THICKNESS	SIZE
PCWHT41018S	1/8"	4' x 10'
PCWHT4818S	1/8"	4' x 8'
PCWHT31236S	3/16"	3' x 12'
PCWHT4836S	3/16"	4' x 8'
PCWHT41036S	3/16"	4' x 10'
PCWHT41236S	3/16"	4' x 12'
PCWHT51036S	3/16"	5' x 10'
PCWHT6836S	3/16"	6' x 8'
PCWHT61036S	3/16"	6' x 10'
PCWHT61236S	3/16"	6' x 12'

"Sign White" Reels

ITEM NO.	THICKNESS	ROLL WIDTH
PCWHT5218R	1/8"	52"
PCWHT7618R	1/8"	76"
PCWHT3936R	3/16"	39"
PCWHT5236R	3/16"	52"
PCWHT6436R	3/16"	64"
PCWHT7636R	3/16"	76"
PCWHT10036R	3/16"	100"



Cleaning & Restoring Plastics



Novus No. 1

Plastic Clean and Shine

Gently cleans all plastics without scratching. Leaves a lustrous shine that resists fogging, repels dust, and eliminates static.

- Resists finger marking
- Contains no abrasives or harsh chemicals

ITEM NO.	SIZE
PLCN1-2	2 oz.
PLCN1-8	8 oz.
PLCN1-64	64 oz.

Novus No. 2

Fine Scratch Remover

Removes fine scratches, haziness and abrasions from most plastics. With repeated use, it restores faded and discolored plastics.

- Removes the damage instead of filling it in
- Buffs out quickly
- After restoring, seals with a coat of polish

ITEM NO.	SIZE
PLCN2-2	2 oz.
PLCN2-8	8 oz.
PLCN2-64	64 oz.

Novus No. 3

Heavy Scratch Remover

Removes heavy scratches and abrasions from most acrylic surfaces. Use when damage is too severe to be restored with No. 2 polish.

- Requires use of No. 2 for final finishing

ITEM NO.	SIZE
PLCN3-2	2 oz.
PLCN3-8	8 oz.
PLCN3-64	64 oz.

NOVUS Polish Mate

ITEM NO.	SIZE
PLCNPM-6	6 pack
PLCNPMR-10	10 pack

LUMAsite® Plastic Sheets

LUMAsite® is American Acrylic's designation for shatterproof sheets cast from 100% acrylic or modified polyester resins. The superior toughness and rigidity of LUMAsite® sheets are the result of reinforcement by an immensely strong web of glass fibers. In sign and display whites and colors these fibers are not visible. In most architectural and designer panels the fibers are deliberately visible, lending a "silken cobweb" effect.

LUMAsite® panels retain their strength and color identity even when exposed long years to most severe outdoor conditions.

Frost-SOS

A light-diffusing panel with an exotic "silken cobweb" appearance. As a lighting diffuser or light-transmitting architectural panel, Frost-SOS combines striking aesthetics and high light transmission.

Parchment-SOS

A light-diffusing panel with a subtle "Shoji" effect. As a lighting diffuser or translucent architectural panel, Parchment-SOS combines a clean white appearance and high light transmission (slightly lower than Frost-SOS).

Rice-SOS

A light-diffusing panel with a stronger "Shoji" effect. Often used in oriental decor, fixtures, and interior treatments, Rice-SOS panels combine an off-white rice paper appearance and medium-high light transmission.

White 1020

A translucent sign white commonly used as a sign background for signs illuminated with high-output fluorescent lamps.

Standard Colors

Ten standard sign colors are available, including translucent ivory, bright translucent colors, a deep translucent blue, opaque browns and black.

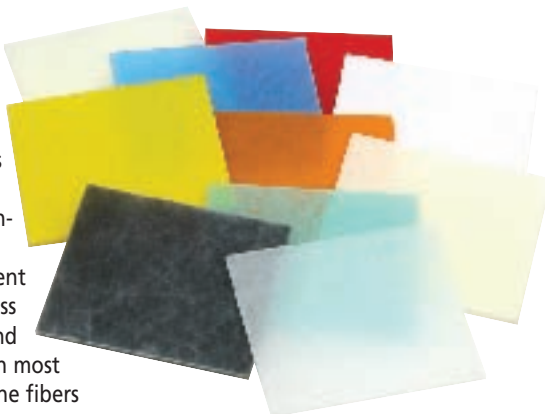

ITEM NO.	THICKNESS	SIZE	COLOR
LS1446PSOS	1/4	4x6	Parchment-SOS
LS1448PSOS	1/4	4x8	Parchment-SOS
LS1848FRSOS	1/8	4x8	Frost-SOS
LS18410FRSOS	1/8	4x10	Frost-SOS
LS1848RSOS	1/8	4x8	Rice-SOS
LS18361020	1/8	3x6	1020 White
LS18381020	1/8	3x8	1020 White
LS183101020	1/8	3x10	1020 White
LS18461020	1/8	4x6	1020 White
LS18481020	1/8	4x8	1020 White
LS184101020	1/8	4x10	1020 White
LS184121020	1/8	4x12	1020 White
LS18581020	1/8	5x8	1020 White
LS185101020	1/8	5x10	1020 White
LS185121020	1/8	5x12	1020 White
LS18382037	1/8	3x8	2037 Yellow
LS183102037	1/8	3x10	2037 Yellow
LS18462037	1/8	4x6	2037 Yellow
LS18482037	1/8	4x8	2037 Yellow
LS184102037	1/8	4x10	2037 Yellow
LS184122037	1/8	4x12	2037 Yellow
LS18582037	1/8	5x8	2037 Yellow
LS185102037	1/8	5x10	2037 Yellow
LS18382146	1/8	3x8	2146 Ivory
LS18482146	1/8	4x8	2146 Ivory
LS184102146	1/8	4x10	2146 Ivory
LS184122146	1/8	4x12	2146 Ivory
LS18310315	1/8	3x10	315 Red
LS1846315	1/8	4x6	315 Red
LS1848315	1/8	4x8	315 Red
LS18410315	1/8	4x10	315 Red
LS183102114	1/8	3x10	2114 Blue
LS18482051	1/8	4x8	2051 Blue
LS184102114	1/8	4x10	2114 Blue
LS184102030	1/8	4x10	2030 Green
LS1848824	1/8	4x8	824 Brown

Polystyrene



Polystyrene

Otherwise known as High Impact Polystyrene, is a versatile economical resin with high aesthetic appeal. Given its versatility, it can be applied in many applications. Easy to vacuum form, silk screen, hot stamp or machine. It is suitable for point of sale display units, indoor signage, showcases and packaging inserts.

Stocked in white. Other colors and sizes available upon request.

ITEM NO.	THICKNESS	SIZE
PLST30	.030	40" x 72"
PLST40	.040	40" x 72"
PLST60	.060	40" x 72"
PLST4880	.080	48" x 96"
PLST4818	.125	48" x 96"

Also available as a special order, white U.V.

ITEM NO.	DESCRIPTION	THICKNESS	SIZE
PLST4818UV	U.V.	.125	48" x 96"

Plexus

Plastic Cleaner & Polish

Recognized as the most effective plastic cleaner, protectant, and polisher on the market.



ITEM NO.	SIZE
PLCP13	13oz.
PLCP7	7oz.

Questions?

Need help selecting the best product? Our "signology" experts will be happy to provide you with clear, concise answers – just ask!



Foam PVC

Rigid PVC Boards Tough and Versatile for Multiple Uses!

KÖMATEX is a lightweight closed-cell, free foam, rigid PVC sheet. It is homogeneously colored with a matte finish that is tough and versatile enough for many of today's applications. The matte surface is the perfect substrate for screen printing, painting, laminating, vinyl lettering and forming projects. Can be sawed, drilled, bent and fabricated using ordinary (plastic) tools and fasteners. Manufactured to be used for interior and limited exterior applications.

DURA-FOAM

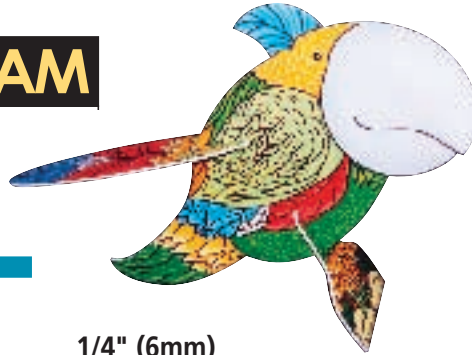

1mm (1/16")

ITEM NO.	SIZE	COLOR
DF1648W	4x8	White

1/8" (3mm)

ITEM NO.	SIZE	COLOR
DF1848W	4x8	White
DF1858W	5x8	White
DF18410W	4x10	White
DF18510W	5x10	White
DF1848BK	4x8	Black
DF18410BK	4x10	Black
DF1848BE	4x8	Beige
DF1848OR	4x8	Orange
DF1848PU	4x8	Purple
DF1848R	4x8	Red
DF1848GR	4x8	Green
DF1848FG	4x8	Forest Green
DF1848LB	4x8	Light Blue
DF1848DB	4x8	Dark Blue
DF1848LG	4x8	Light Grey
DF1848DG	4x8	Dark Grey
DF1848LY	4x8	Light Yellow
DF1848DY	4x8	Dark Yellow

1/4" (6mm)

ITEM NO.	SIZE	COLOR
DF1448W	4x8	White
DF1458W	5x8	White
DF14410W	4x10	White
DF14510W	5x10	White
DF1448BK	4x8	Black
DF14410BK	4x10	Black
DF1448BE	4x8	Beige
DF1448OR	4x8	Orange
DF1448PU	4x8	Purple
DF1448R	4x8	Red
DF1448GR	4x8	Green
DF1448FG	4x8	Forest Green
DF1448LB	4x8	Light Blue
DF1448DB	4x8	Dark Blue
DF1448LG	4x8	Light Grey
DF1448DG	4x8	Dark Grey
DF1448LY	4x8	Light Yellow
DF1448DY	4x8	Dark Yellow

3/8" (10mm)

ITEM NO.	SIZE	COLOR
DF3848W	4x8	White
DF3848BK	4x8	Black

1/2" (12mm)

ITEM NO.	SIZE	COLOR
DF1248W	4x8	White
DF12410W	4x10	White
DF1248BK	4x8	Black
DF12410BK	4x10	Black

3/4" (19mm)

ITEM NO.	SIZE	COLOR
DF3448W	4x8	White
DF3448BK	4x8	Black

1" (25mm)

ITEM NO.	SIZE	COLOR
DF148W	4x8	White
DF1410W	4x10	White
DF148BK	4x8	Black

KÖMACEL

Rigid PVC Boards

High flexural strength!



An integral skin-foam sheet made of rigid PVC according to the Celuka process, KÖMACEL has characteristics, such as ease of fabrication, that make it appropriate for applications in a variety of industries, including advertising, construction, electrical, photographic and others.

Among KÖMACEL's most important features are its high flexural strength and light weight. It is sound- and vibration-absorbent with low thermal conductivity and high insulating value. Weatherproof and light-fast, it is also chemical-resistant and non-corroding. Because it will not absorb water, it resists rot, and it is ready for indoor or outdoor use without pretreatment. The sheets are available in white only.

4' x 8' Boards

ITEM NO.	THICKNESS
KC53248	5/32" (4mm)
KC3848	3/8" (10mm)
KC1448W	1/4" (6mm)
KC1248	1/2" (13mm)
KC3448	3/4" (19mm)
KC148	1" (24mm)
KC13648	1-3/16" (30mm)

48" x 118" Boards

ITEM NO.	THICKNESS
KC34410	3/4" 19mm
KC1410	1" 24mm

KÖMACEL PLUS Boards

A Celuka sheet you can digital print. With a semi-rough surface, Kömacel Plus is also ideal for laminating and painting, and it gives the finished digital print an "aged look."

ITEM NO.	SIZE	THICKNESS
KCP1410	4x10	1" (24mm)
KCP148	4x8	1" (24mm)
KCP3448	4x8	3/4" (19mm)

LusterBoard/SignPly

Hardwood Core, Aluminum Surface - 1/2"

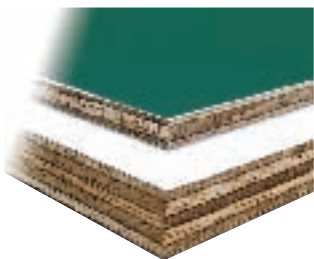

LusterBoard offers a colorfast, painted aluminum surface. It has the strength of a sheet of MDO which is nearly twice as thick, along with excellent impact resistance. Average outdoor life expectancy is 5-7 years. Easy to fabricate with standard wood cutting tools.

LusterBoard - 2-Sides Finished

ITEM NO.	SIZE	THICKNESS	COLOR
OLB12WM	4' x 8'	1/2"	White
OLB12410WW	4' x 10'	1/2"	White

SignPly - 1-Side Finished

ITEM NO.	SIZE	THICKNESS	COLOR
OSP12	4' x 8'	1/2"	White
OSP12410	4' x 10'	1/2"	White

Additional colors & sizes available upon special order request.

12 available colors:

White, Silver Metallic, Ivy Green, Sunset Red, Brite Yellow, Regal Bronze, Ivory, Royal Blue, Sand Beige, Raven Black, Matte Black, and Candy Apple Red.

U Sign Hangers

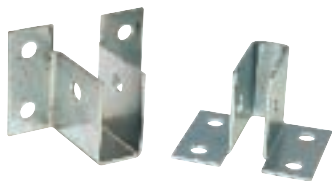

ITEM #	SIZE
HDSHU12	1/2"
HDSHU34	3/4"

SignBoard

Hardwood Core, Vinyl Surface

An economical panel, ideal for pressure sensitive vinyl, Omega SignBoard should be used for signs of a more temporary nature like real estate signs, and billboards.



- Lighter and stronger than MDO.
- A glossy vinyl surface, does not require time consuming and costly painting, is smooth and uniform, and will not flake or peel like a painted surface.
- Average life expectancy 3-5 years.
- Easy to fabricate with standard wood cutting tools.
- Color: white

ITEM NO.	SIZE	THICKNESS	FINISHED
OSB121	4' x 8'	1/2"	1 side
OSB122	4' x 8'	1/2"	2 sides
OSB124101	4' x 10'	1/2"	1 side



Aluminum "J" Cap

Two-part Snap

For mounting and framing wall installations.



ITEM NO.	THICKNESS	LENGTH	COLOR
	1/4"	98" L	White

Aluminum "H" Cap

Two-part Snap

For joining panels.



ITEM NO.	THICKNESS	LENGTH	COLOR
OHC12	1/2"	98"	White Paintable

Aluminum Outside Corner Cap

Two-part Snap

For joining panels.



ITEM NO.	THICKNESS	LENGTH	COLOR
	1/4"	120"	White Paintable

PVC "H" Joint Extrusion

For joining panels.

ITEM NO.	THICKNESS	LENGTH	COLOR
OHC14OHC14	1/4"	120"	White Paintable
OHC12	1/2"	120"	White Paintable

Laminated Panels

Edge Cap

A styrene plastic "U" channel that is placed over the edges of the panels to create a tight, attractive seal.

Omega SignBoard®, LusterBoard® and Sign-Ply® have hardwood cores and require edge sealing to achieve exterior durability.

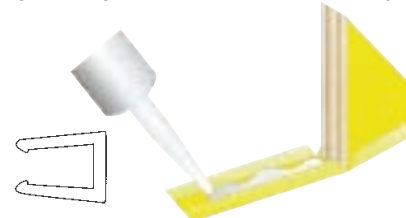

ITEM NO.	THICKNESS	LENGTH	COLORS
OLEC14	1/4"	98"	White
OLEC14BK	1/4"	98"	Black
OLEC14B L	1/4"	98"	Blue
OLEC14BZ	1/4"	98"	Bronze
OLEC14GR	1/4"	98"	Green
OLEC14GY	1/4"	98"	Grey
OLEC14I	1/4"	98"	Ivory
OLEC14R	1/4"	98"	Red
OLEC14Y	1/4"	98"	Yellow
OLEC12	1/2"	98"	White
OLEC12BK	1/2"	98"	Black
OLEC12BL	1/2"	98"	Blue
OLEC12BZ	1/2"	98"	Bronze
OLEC12GR	1/2"	98"	Green
OLEC12GY	1/2"	98"	Grey
OLEC12I	1/2"	98"	Ivory
OLEC12R	1/2"	98"	Red
OLEC12Y	1/2"	98"	Yellow
OLEC34	3/4"	96"	White
OLEC34BK	3/4"	96"	Black

Plastic Capping



ITEM NO.	COLOR
PCCW48	96" (fits 1/8") White

Roper Whitney Hand Notcher

No. 541 Series 90° Hand Notcher w/90° Blade Set



ITEM NO. HD541

Laminated Panels

Alumalite

**Corrugated Plastic Core
with Two-Sided Finished
Aluminum Surfaces**



- Alumalite is ideal for paints, screen print inks, and pressure sensitive vinyl.
- Thin and light, yet surprisingly rigid.
- Cuts and routs like butter using standard carpentry tools.
- Can withstand winds over 120 MPH.
- Water, sun and temperature resistant, with a "Class A" flame spread rating.
- Vinyl Edge Caps are available in a variety of colors where a decorative edge is required.
- Average outdoor life expectancy is 10 years.

6mm (1/4")

ITEM NO.	SIZE	COLOR
OAL4814W	4' x 8'	White
OAL4814BK	4' x 8'	Black
OAL4814CR	4' x 8'	Candy Apple Red
OAL4814GR	4' x 8'	Ivy Green
OAL4814I	4' x 8'	Ivory
OAL4814MBK	4' x 8'	Matte Black
OAL4814RB	4' x 8'	Royal Blue
OAL4814SB*	4' x 8'	Sand Beige
OAL4814SM*	4' x 8'	Silver Metallic
OAL4814SR*	4' x 8'	Sunset Red
OAL4814Y*	4' x 8'	Yellow
OAL4814B*	4' x 8'	Regal Bronze
OAL41014W	4' x 10'	White
OAL41014SB*	4' x 10'	Sand Beige
OAL41014SM*	4' x 10'	Silver Metallic/Mill
OAL41014MBK*	4' x 10'	Matte Black
OAL5814W*	5' x 8'	White
OAL51014W	5' x 10'	White

10mm

ITEM NO.	SIZE	COLOR
OAL4812W	4' x 8'	White*
OAL41012W	4' x 10'	White*
OAL51012W	5' x 10'	White*

*Available as special order

Econolite

**Corrugated Plastic Core
with One-Sided Finished
Aluminum Surface**

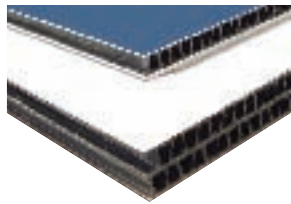

- An economical alternative to Alumalite — All the benefits of Alumalite, however only one aluminum side is painted. The other side is a light gauge, aluminum backer.
- When properly supported on 24" center, Econolite can be used for post & panel and/or billboard applications.

6mm (1/4")

ITEM NO.	SIZE	COLOR
OEL4814W	4' x 8'	White
OEL4814Y*	4' x 8'	Yellow
OEL4814MBK*	4' x 8'	Matte Black
OEL4814RB*	4' x 8'	Royal Blue
OEL4814SM*	4' x 8'	Silver Metallic
OEL4814I*	4' x 8'	Ivory
OEL4814G*	4' x 8'	Green
OEL4814CR*	4' x 8'	Candy Apple Red
OEL4814R*	4' x 8'	Sunset Red
OEL4814SB*	4' x 8'	Sand Beige
OEL4814B*	4' x 8'	Regal Bronze
OEL4814BK*	4' x 8'	Black
OEL41014MBK*	4' x 10'	Matte Black

10mm

ITEM NO.	SIZE	COLOR
OEL4812W	4' x 8'	White
OEL4812BK*	4' x 8'	Black
OEL4812G*	4' x 8'	Green
OEL4812Y*	4' x 8'	Yellow
OEL4812I*	4' x 8'	Ivory
OEL4812MBK*	4' x 8'	Matte Black
OEL4812R*	4' x 8'	Sunset Red
OEL4812RB*	4' x 8'	Royal Blue
OEL4812S*	4' x 8'	Silver
OEL4812B*	4' x 8'	Regal Bronze
OEL4812CR*	4' x 8'	Candy Apple Red
OEL4812SB*	4' x 8'	Sand Beige
OEL41012W*	4' x 10'	White

*Available as special order

D-Lite

**Corrugated Plastic Core-3mm
with One-sided or Two-Sided
Finished Aluminum Surfaces**



- An economical alternative to Alumalite®, Dibond®, and Sheet metal.
- Only 3mm thick, yet strong & lightweight
- Proper installation requires structural support 24" on center.

Recommended Applications

Wall mount, Cut-out, Kiosk, Photo Mounting, Post and Panel (supported), Billboard Fascia, Channel Letterbacks, Hanging Signs, POP Displays.

3mm (1/8")

ITEM NO.	SIZE	FINISH	COLOR
ODL48181SW	4' x 8'	1 side	White
ODL48182SW*	4' x 8'	2 sides	White
ODL410181SW*	4' x 10'	1 side	White

*available as special order

Colors available as special order:

White, Silver Metallic, Ivy Green, Sunset Red, Brite Yellow, Regal Bronze, Ivory, Royal Blue, Sand Beige, Raven Black, Matte Black, and Candy Apple Red

Mounting Flute Clips

Recommend 1 clip per 2' of panel edge.
Packages of 100.



ITEM NO. OFC

Dowel Pins

Recommend 1 pin every 6" to 12" along panel joints.

1/8" Dia x 4" Long, 100/pack.

ITEM NO. ODP

Laminated Panels

Aluminum Composite Panels

DURA-BOND

A decorative aluminium composite panel with a 1001 uses!
DuraBond is a polyethylene core with 0.3mm colored aluminium sheet either side.

It is a pre-finished product that requires no decoration.

- Smooth Surface Coating
- Excellent Impact Resistance
- Outstanding Weather Resistance
- Easy to Maintain and Install
- Incredible dimensional stability at extremes of temperature
- Excellent Resistance to Ultraviolet Radiation
- Corrosion resistant



2mm

ITEM NO.	SIZE	COLOR
DB482MWGW	4' x 8'	Matte White/Gloss White

DURA-BOND LITE, 3mm

ITEM NO.	SIZE	COLOR
DB483GWM	4' x 8'	Gloss White/Mill

3mm

ITEM NO.	SIZE	COLOR
DB483GWGW	4' x 8'	Gloss White/Gloss White
DB483GBKMBK	4' x 8'	Gloss Black/Matte Black
DB483SMM	4' x 8'	Silver Mirror/Mill
DB483GMM	4' x 8'	Gold Mirror/Mill
DB483BCM	4' x 8'	Brushed Silver/Mill
DB483BGBC	4' x 8'	Brushed Gold/Brushed Copper
DB483BRCSM	4' x 8'	Silver Brushed/Silver Metallic
DB483IVGIVG	4' x 8'	G.Ivy Green/M.Ivy Green
DB483KGKG	4' x 8'	G.Kelly Green/M.Kelly Green
DB483MBMB	4' x 8'	G.Marine Blue/M.Marine Blue
DB483SMSM	4' x 8'	G.Silver Met./M.Silver Metallic
DB483LBL	4' x 8'	Gloss Blue/Matte Blue
DB483RDRD	4' x 8'	Gloss Red/Matte Red
DB483YELYEL	4' x 8'	Gloss Yellow/Matte Yellow
DB4103GWGW	4' x 10'	Gloss White/Gloss White
DB4103MWGW	4' x 10'	Matte White/Gloss White
DB4103GBKMBK	4' x 10'	Gloss Black/Matte Black
DB4123GWGW	4' x 12'	Gloss White/Gloss White
DB583GWGW	5' x 8'	Gloss White/Gloss White
DB5103GWGW	5' x 10'	Gloss White/Gloss White
DB5103MWGW	5' x 10'	Matte White/Gloss White
DB5103YELYEL*	59" x 10'	Gloss Yellow/Matte Yellow
DB6103MWGW	78.75" x 10'	Matte White/Gloss White
DB5103BKBK	59" x 10'	Gloss Black/Matte Black

6mm

ITEM NO.	SIZE	COLOR
DB486MWGW	4' x 8'	Matte White/Gloss White
DB486GWGW	4' x 8'	Gloss White/Gloss White
DB486MBKMBK	4' x 8'	Matte Black/Matte Black
DB486GBKGBK	4' x 8'	Gloss Black/Gloss Black
DB4106GWGW	4' x 10'	Gloss White/Gloss White
DB4106MBKMBK	4' x 10'	Matte Black/Matte Black
DB4106GBKGBK	4' x 10'	Gloss Black/Gloss Black
DB4126GWGW	4' x 12'	Gloss White/Gloss White
DB586GWGW	5' x 8'	Gloss White/Gloss White
DB5106GWGW	5' x 10'	Gloss White/Gloss White
DB5126GWGW	5' x 12'	Gloss White/Gloss White

DIGI-BOND

A specially developed coating is applied to both sides of the panel providing vastly improved ink adhesion. The complete flatness of DigiBond makes the surface and your design look absolutely perfect.

DigiBond can be machined after printing, with no cracks or damage to the surface. Panels can be curved and folded to suit any job requirement.



ITEM NO.	THICKNESS	SIZE	COLOR
DB483DIG	3mm	4' x 8'	Satin White/Satin White

*Special order only

Laminated Panels



MDO Boards

MDO plywood is a multiple-use industrial panel whose surface provides superior paint-holding characteristics and is highly resistant to chemicals and weather when properly coated.

MDO panels offer consistent quality and dependability for today's signmaker. Combines the strength of high quality plywood with tough overlays to give you superior surface performance and much longer life than other sign materials.

Wherever a smooth, easily painted, durable surface is required, MDO is a superb choice.

MDO Primed and Painted Panels

MDO panels are now available prefinished which help reduce production time and provide a uniform prime coat. Panel edges are also sealed with a matching prime color. The primed overlay is available on one or both sides. Also available painted white.

4' x 8'

ITEM NO.	THICKNESS	DESCRIPTION
MDO48122S	1/2"	2-Sided
MDO48122SP	1/2"	2-Sided Primed
MDO48122SWHT	1/2"	2-Sided Painted White
MDO48342S	3/4"	2-Sided
MDO48342SP	3/4"	2-Sided Primed
MDO48342SWHT	3/4"	2-Sided Painted White

4' x 10'

ITEM NO.	THICKNESS	DESCRIPTION
MDO410122SP	1/2"	2-Sided Primed
MDO410342SP	3/4"	2-Sided Primed

Sign Hanger

For Masonite, plywood, or metal swing signs. Steel - Zinc plated

ITEM #	SIZE
HDSH-12	1/2"
HDSH-34	3/4"



KING COLORCORE

King ColorCore® is a versatile, environmentally stabilized sheet with multiple layers of contrasting color. Its thin cap layers and bright, primary colors make it ideal for sign, marine, playground and recreational applications.



The sheets are easy to engrave and machine, as the cap is approximately ten percent of nominal thickness for high production speeds.

Base materials are FDA approved as are most pigments. It is made with high-impact-resistant polymer to handle more abuse than conventional sign materials.

Standard Size: 48" x 96"

Standard Thickness: 1/4", 1/2", 3/4"

Custom sizes and thicknesses available.

Available colors:

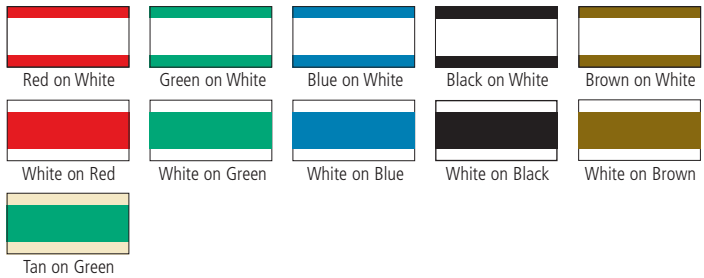

ITEM NO.	THICKNESS	COLOR
CC4812BKWBK	1/2"	Black/White/Black
CC4812BLWBL	1/2"	Blue/White/Blue
CC4812GNWGN	1/2"	Green/White/Green
CC4812RDWRD	1/2"	Red/White/Red
CC4812TNGNTN	1/2"	Tan/Green/Tan
CC4812WBKW	1/2"	White/Black/White
CC4812WRDW	1/2"	White/Red/White
CC4814BKWBK	1/4"	Black/White/Black
CC4814BLWBL	1/4"	Blue/White/Blue
CC4814BRWBR	1/4"	Brown/White/Brown
CC4814GNWGN	1/4"	Green/White/Green
CC4814RDWRD	1/4"	Red/White/Red
CC4814WBKW	1/4"	White/Black/White
CC4814WBLW	1/4"	White/Blue/White
CC4814WGNW	1/4"	White/Green/White
CC4814WRDW	1/4"	White/Red/White

Foam Board

Paper Faced Foamboard

Sold by the case only

INSITE® REVEAL® is a paper-faced, multipurpose "memory" foamboard with the best performance of any board in its class. Available in bright-white or all-black. Engineered to retain its thickness during mounting, laminating, screen-printing and die-cutting. Highly warp resistant.

ITEM NO.	THICKNESS	SIZE	COLOR	PCS./CARTON
FBI4636W	3/16"	4x6	White	25
FBI4836W	3/16"	4x8	White	25
FBI4836BK	3/16"	4x8	Black	25
FBI41036W	3/16"	4x10	White	25
FBI4814W	1/4"	4x8	White	12

Paper Faced Foamboard

with Pressure-Sensitive Adhesive

Proprietary Reveal® memory foam center faced on one side with smooth, clay coated paper, and an adhesive surface on the other.

ITEM NO.	THICKNESS	SIZE	COLOR	PCS./CARTON
FBIPSA23W	24"x36"	3/16"	White	
FBIPSA23BK	24"x36"	3/16"	Black	

Heavy-Duty Paper Faced Foamboard

Peel N' Stick, with Pressure-Sensitive Adhesive

Heavy-duty foam boards with double-thick surface liners and high-density foam. RYNO BOARD® is much more resistant to denting and warping than standard paper-faced foam boards. The combination of high density foam centers and double thick surface liners produce rugged yet economical foam boards with exceptional compressive strength and superior dimensional stability.

ITEM NO.	THICKNESS	SIZE	COLOR	PCS./CARTON
FBRPSA4814W	1/4"	4x8	White	
FBRPSA4814BK	1/4"	4x8	Black	

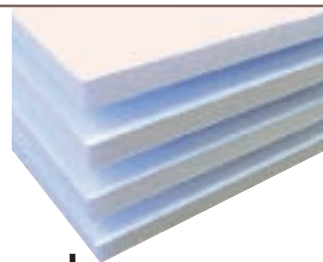

Ultra Core - Foam Core

The Reliable, Economical Standard

Sold by the case only

For temporary or light-duty uses, ULTRA CORE is the best choice available.



It is both economical and well manufactured to provide you a quality foam-centered art board at an affordable price. The panels are rigid and smooth, and are easily cut with a utility knife, razor or die. Ultra Core is ideal for mounting and framing photos and prints, and also works well for screen printing, temporary signs, architectural models, promotional displays and point-of-purchase sales.

Size: 4' x 8'

ITEM NO.	THICKNESS	COLOR	PCS./CARTON
FUC316W	3/16"	White	25
FUC316BK	3/16"	Black	25

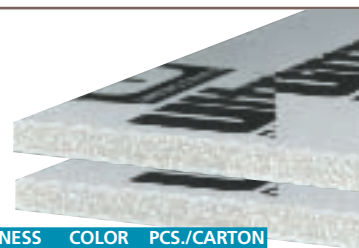

For other available sizes please contact your S&F sales rep

Ultra Core - Peel N' Stick

Ultra Core Peel N' Stick is available for quick and simple mounting of photos, prints or computer graphics – excellent for presentation materials.

ITEM NO.	SIZE	THICKNESS	COLOR	PCS./CARTON
FUCPNS3162436	24" x 36"	3/16"	White	24
FUCPNS3163240	32" x 40"	3/16"	White	24
FUCPNS31648	48" x 96"	3/16"	White	16

Ultra Mount - Foam/Poly Coated Kraft Paper

Photos and Graphics love this board

ULTRA MOUNT is a lightweight structural panel consisting of a rigid polystyrene foam core faced on both sides by poly coated Kraft paper. An excellent choice for interior signage, photo mounting, exhibits, and point of purchase displays.

Size: 4' x 8'

Sold in single sheets or by the case

ITEM NO.	THICKNESS	COLOR	PCS./CARTON
FUM316W	3/16"	White	16
FUM316BK	3/16"	Black	16
FUM12W	1/2"	White	12
FUM12BK	1/2"	Black	12
FUM34W	3/4"	White	8
FUM1W	1"	White	12

Ultra Mount - Peel N' Stick

Same as regular Ultra Mount but in Peel N' Stick version, coated on one side with high tack pressure sensitive adhesive for convenience and simplicity.

ITEM NO.	THICKNESS	COLOR	PCS./CARTON
FUMPNS316W	3/16"	White	16

For other available sizes please contact your S&F sales rep



Foam Board

Ultra Board - Foam/Polystyrene

Outlasts. Outperforms all others



ULTRA BOARD is a lightweight structural panel consisting of a rigid polystyrene foam core faced on both sides by a smooth, moisture resistant sheet of solid polystyrene. Designed primarily for interior use.

An excellent choice for signage, photo mounting, exhibits, point of purchase displays and routed letters.

Sold in single sheets or by the case

Size: 4' x 8'

ITEM NO.	THICKNESS	COLOR	PCS./CARTON
FUB316W	3/16"	White	16
FUB316BK	3/16"	Black	16
FUB12W	1/2"	White	12
FUB12BK	1/2"	Black	12
FUB34W	3/4"	White	8
FUB34BK	3/4"	Black	8
FUB1W	1"	White	12
FUB1BK	1"	Black	12
FUB112W	1-1/2"	White	8
FUB2W	2"	White	6
FUB3W	3"	White	4

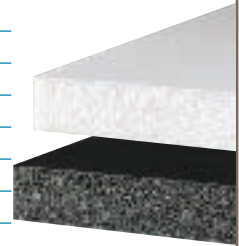

For other available sizes please contact your S&F sales rep

Ultra Plus - Foam/PVC Finish

The Tough Guy Braves The Elements



This is the lightweight, durable, rigid alternative to conventional outdoor materials. Ultra Plus is made of high-quality extruded polystyrene foam between two layers of 1mm or 2mm expanded PVC liner. It is extremely dent-resistant, warp-resistant, weatherproof and rigid.

You can treat and cut Ultra Plus just like wood use a circular saw, router, band saw or scroll saw.

Anchor it with adhesives or with screws and washers. Ultra Plus will not rot and is not degraded by direct sunlight, wind or moisture.

Special order, sold by the case only

Size: 4' x 8'

ITEM NO.	THICKNESS	COLOR	PCS./CARTON
FUP14W	1/4"	White	12
FUP14BK	1/4"	Black	12
FUP12W	1/2"	White	12
FUP12BK	1/2"	Black	12
FUP34W	3/4"	White	8
FUP1W	1"	White	12
FUP112W	1-1/2"	White	8
FUP2W	2"	White	6
FUP3W	3"	White	4



For other available sizes please contact your S&F sales rep

Ultra Aluminum

A Brilliant Alternative to Metals!

Elegant metal signs and letters can cost you and your client a bundle; now there is a lightweight, less expensive, easily crafted alternative. ULTRA ALUMINUM delivers the same impact and appeal as metal, but in a durable, versatile foam-centered product.

Ultra Aluminum is the ideal material for decorative letters and logos. It can be sawed or routed, and is easier to craft than solid metal. Ultra Aluminum comes in five finishes — polished gold, brushed gold, polished chrome, brushed chrome and acrylic baked white. Choose from white or black core.

Special order, sold by the case only

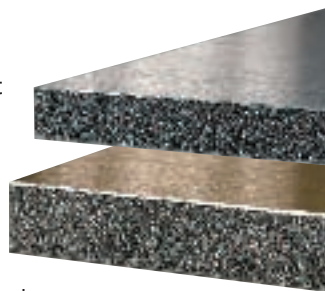

Two-sided aluminum panels are also available. Please contact your S&F Sales rep. for more details.

Corrugated Plastic Sheets

Coroplast Corrugated Sheets

A continuously extruded fluted polypropylene copolymer plastic sheet with no lamination.

Coroplast is suitable for use indoors and outdoors. It provides permanent durability at the price of temporary conventional materials. Major savings accrue from coroplast's exceptional lightweight factor (shipping, handling and installation.) It is washable and reusable, Add it all up and you'll see why this fluted plastic sheet has proven perfect for pole signs, indoor and outdoor displays, real estate signs, etc.



Available colors:



4' x 8', 4mm (1/4")

ITEM NO.	COLOR
CP48BK	Black
CP48BR	Brown
CP48CL	Clear
CP48BL	Navy Blue
CP48GY	Gray
CP48G	Green
CP48I	Ivory
CP48LB	Light Blue
CP48MB	Medium Blue
CP48O	Orange
CP48PU	Purple
CP48R	Red
CP48W	White
CP48Y	Yellow

4' x 10', 4mm (1/4")

ITEM NO.	COLOR
CP410W	White

4' x 8', 10mm (3/8")

ITEM NO.	COLOR
CP4810BK	Black
CP4810CL	Clear
CP4810DBL	Navy Blue
CP4810GY	Gray
CP4810G	Green
CP4810LBL	Light Blue
CP4810MB	Medium Blue
CP4810O	Orange
CP4810R	Red
CP4810W	White
CP4810Y	Yellow

4' x 10', 10mm (3/8")

ITEM NO.	COLOR
CP41010W	White
CP41010Y	Yellow

4' x 8', 13mm (1/2")

ITEM NO.	COLOR
CP4813W	White

Custom sizes are available from any color

Corrugated Sheets Economical



4' x 8'

ITEM NO.	COLOR	THICKNESS
CP484W-25	White	4mm
CP4810W-10	White	10mm

S&F Exclusive Fluorescent Colors

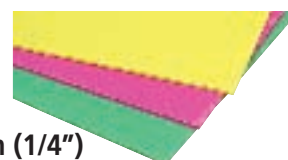

4' x 8', 4mm (1/4")

ITEM NO.	COLOR
CP484FLBL	Flourescent Blue
CP484FLOR	Flourescent Orange
CP484FLRD	Flourescent Red
CP484FLGR	Flourescent Green
CP484FLPI	Flourescent Pink
CP484FLYE	Flourescent Yellow
CP484LY	Flourescent Lemon Yellow

Smooth Corrugated Sheets for printing



4' x 8'
Pack of 25

ITEM NO.	COLOR
CP484W-SM-25	White

Coroplast Blanks

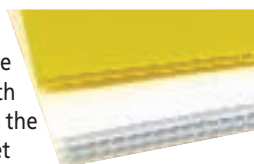

All stock blanks are 4mm thickness with the flutes running the length of the sheet parallel to the second dimension. Other sizes and specifications can be custom ordered by contacting your sales rep.

ITEM NO.	SIZE (WxH)*	COLOR
CP2418W	24" x 18"	White
CP1824W-100	18" x 24"	White
CP2418Y	24" x 18"	Yellow
CP2424W	24" x 24"	White
CP3624W	36" x 24"	White
CP3624Y	36" x 24"	Yellow

*Flutes follow the height size

Coroclaw Coroplast Cutter

Cut along the flutes or score along the flutes to make a stand or cover. Every shop needs at least one!



- Score cut with the outer most talon.
- Cut through using the second talon.

ITEM NO.	DESCRIPTION
CPCC	for 4mm Coroplast
CPCC10	for 10mm Coroplast

Precision Board

Precision Board

High Density Urethane

Precision Board offers significant advantages to wood. It is a rigid, closed cell, high density urethane material. It can be sandblasted, routed, carved or used in any other typical wood application.

Precision Board works well indoors as well as outdoors. High or low environmental temperatures, rain, snow, ice or frequent sprinkler waterings have no effect on this state-of-the-art material. Precision Board is fire rated.



15/lb. Density

ITEM NO.	SIZE	THICKNESS
PB151248	4' x 8'	1/2"
PB153448	4' x 8'	3/4"
PB15148	4' x 8'	1"
PB1511248	4' x 8'	1 1/2"
PB15248	4' x 8'	2"
PB15348	4' x 8'	3"
PB15448	4' x 8'	4"
PB151410	4' x 10'	1"
PB15112410	4' x 10'	1 1/2"
PB152410	4' x 10'	2"
PB1511258	5' x 8'	1 1/2"
PB15258	5' x 8'	2"
PB15112510	5' x 10'	1 1/2"
PB152510	5' x 10'	2"

All other sizes or density are available as a custom order

Finials



ITEM NO.	DESCRIPTION
DBFIN-ACORN-4	SET 4" Acorn #1680978F
DBFIN-BALL-4	SET 4" Ball #1680989F
DBFIN-OVAL-4	SET 4" Oval #1672784F
DBFIN-ACORN-6	SET 6" Acorn #168079F
DBFIN-BALL-6	SET 6" Ball #1680977F
DBFIN-OVAL-6	SET 6" Oval #1680980F

PB Fast Set

An amber colored, one part, urethane adhesive that fully cures in 30 minutes. It works well for indoor or outdoor applications. It cures from liquid to solid with a slight amount of moisture. 1 quart.

ITEM NO. PBFASSETQ

PB Bond-240

An amber colored, one part, urethane adhesive that works well for indoors or outdoor applications. It cures from a liquid to a solid state with a slight amount of moisture.

ITEM NO. PBBOND-240P PINT
ITEM NO. PBBOND-240Q QUART



FSC-88 WB Primer/Filler

A sprayable, brushable, or rollable waterbased primer/filler that is used to fill and smooth Precision Board prior to finishing with paints and coatings. 1 gallon.

ITEM NO. PBFSC-88WB



Companion Products

FSC-360 WB Crack Filling & Repair

A waterbased crack filling and repair material specifically formulated for use on Precision Board high density urethane (HDU). It also works well on wood, metal and adheres to most plastics. 1 gallon.

ITEM NO. PBFSC-360WB



PB Hard Coat

A rock hard protective coating. Easy to create smooth or textured surface (ie. Stipple and wood grain). Great for making Precision Board abuse proof.

ITEM NO. PBHARDCOAT-PKIT



TSF-45 Texture Surface Finish

An extremely tough, flexible coating that has been compounded specifically for use in creating texture surfaces on Precision Board HDU. 1 gallon.

ITEM NO. PBTSF-45



PB-Resin Clear Coat

For creating a fast ultra smooth surface. No Priming or sanding required. Part A&B, 1 quart ea.

ITEM NO. PBRESIN-QKIT



Jay Cooke All Purpose Sign Primer

Jay Cooke's All Purpose Sign Primer is the industry leading high build, water-based, universal primer, sealer and stain blocker. Can be used for both interior and exterior application and can be used with both latex and enamel topcoats. It is absent of harmful solvents, it is low odor and requires only water clean-up. Jay Cooke's All Purpose Sign Primer fills the need of both the commercial shop and dimensional sign maker.

ITEM NO. PJCSPPG



Cooley SM-42

Cooley

**Seamless, Flexible Backlit Substrate,
20 oz.**

Features excellent lay-flat properties and a fine scrim which is virtually invisible. This seamless wide sign substrate can be decorated in a number of ways, including pressure sensitive films, spray paints, silk screen inks, heat transfer paint or solvent based inkjet inks. This material can also be used for some digital printing applications.

Sold by the foot.

ITEM NO.	WIDTH
AWFCSM42102	102"
AWFCSM42126	126"
AWFCSM42150	150"
AWFCSM42196	196"



SF 20 oz. Flexible Face Banner

White translucent gloss banner for wide format backlit display.

ITEM NO.	SIZE
SFBA20BL54-G	54" x 105'
SFBA20BL62-G	62" x 105'
SFBA20BL80-G	80" x 105'
SFBA20BL98-G	98" x 105'



Exotic™ Fabric



The S&F Exotic™ is a vinyl coated, polyester, reinforced fabric finished with a laminated vinyl top surface. It features the following benefits:

- Extremely flexible
- Highly durable
- Dimensionally stable
- Advanced scrim design
- Super translucency
- Excellent dirt resistance
- Ideal for digital printing
- 54" width sold in full roll only, 60" & 80" sold in full rolls or cut yardage.

ITEM NO.	SIZE	WIEGHT
AWF1200-54	54" x 75'	15 oz.
AWF1200	60" x 150'	15 oz.
AWF5000N	80" x 75'	16 oz.

Magnetic Sheets

S&F SUPPLIES
Your Complete Source for
LARGE FORMAT
Printers & Media
Billboards...

Fleet Graphics

Trade Show Signage

Visit the S&F Digital Graphics Showroom

Flexible Magnetic Sheeting

A thermoplastic, permanent magnetic product with a high-intensity, multi-pole magnetic arrangement designed to produce superior holding power on most metallic surfaces. Our magnetic sheeting will withstand cracking at 68°F while wrapped around a .5" diameter rod.

30 mil. Available in many colors.

Sizes Available: 24"x10', 24"x25', 24"x50'

.030 Thickness, Matte Finish

ITEM NO.	COLOR	SIZE
MGW10	White	24" x 10'
MGW25	White	24" x 25'
MGW50	White	24" x 50'
MGBK10	Black	24" x 10'
MGBK50	Black	24" x 50'
MGBL10	Blue	24" x 10'
MGBL50	Blue	24" x 50'
MGY10	Yellow	24" x 10'
MGY50	Yellow	24" x 50'
MGBR10	Brown	24" x 10'
MGGR10	Green	24" x 10'
MGI10	Ivory	24" x 10'
MGOR10	Orange	24" x 10'
MGR10	Red	24" x 10'
MGSL10	Silver	24" x 10'
MGG010	Gold	24" x 10'

Custom widths, thicknesses and lengths available upon request.

.015 Thickness

ITEM NO.	COLOR	SIZE
MGW152450	Matte White	24" x 50'

Magnetic



Pressure-Sensitive Magnetic Strips

Magnetic Strips are produced in a wide variety of widths, lengths and thicknesses. Plus, they can be custom pre-cut or pre-scored to fit your applications.



Black Finish

ITEM NO.	SIZE	THICKNESS
MGWS12	1/2" x 100'	.060
MGWS34	3/4" x 100'	.060
MGWS1	1" x 100	.060

DigiMAG Magnetic Sheets

For Inkjet Printers

.025 Thickness. Available in matte or gloss finish.



ITEM NO.	SIZE	FINISH
DIGIMAG2425M	24 3/8" x 25'	Matte
DIGIMAG2425GL	24 3/8" x 25'	Gloss

Day Glo

Fluorescent Signwriter paper. Brilliant fluorescent colored paper. Glows in sunlight. 60# - coated one side. Colors not permanent.



ITEM NO.	COLOR	SIZE
PA36LO	Light Orange	36" x 100'
PA36CH	Chartreuse	36" x 100'
PA36DR	Orange-Red	36" x 100'
PA36R	Red	36" x 100'
PA36P	Pink	36" x 100'
PA36G	Green	36" x 100'
PA36DO	Orange	36" x 100'
PA48CH	Chartreuse	48" x 100'
PA448R	Red	48" x 100'
PA48P	Pink	48" x 100'
PA48G	Green	48" x 100'
PA48O	Orange	48" x 100'



www.sfsupplies.com



INDEX

DIGITAL MEDIA	5
SIGN VINYL	45
VINYL AND WRAP SUPPLIES	59
WIDE FORMAT EQUIPMENT	73
VINYL CUTTERS	87
ENGRAVERS	95
SOFTWARE	97
SUBSTRATES	105
BANNER	127

Ready-Made Banner.....128
 Banner Accessories.....129-136
 Banner Stands137-138

SIGN DISPLAY	139
TAPES & ADHESIVES	145
PAINT	153
NEON SUPPLIES & EQUIPMENT	167
TRANSFORMERS	207
LED SYSTEMS	229
LIGHTING & ELECTRIC	243
SIGN EXTRUSION	267
LETTER & ACCESSORIES	277
MOUNTING HARDWARE	281
EQUIPMENT & SHOP TOOLS	293

Ready-Made Banner

Long Life Webbing Blank Banners

Introducing our much improved outdoor banner. S&F is now using seat belt webbing! This strong material is much easier to tie. It also aids the entire banner to lay flat, regardless of the length of the banner.



- You will find it much easier to lay vinyl lettering, graphics or even hand lettering.
- The webbing is sewn into all four sides of the banner, cutting out puckering forever.
- Double stitch hems keep banner in perfect shape.
- Customized 10oz. banners with nylon webbing reinforced with loops on ends. Grommets every 2'.



ITEM NO.	SIZE	ITEM NO.	SIZE
BAB2410W	2' x 4'	BAB3810W	3' x 8'
BAB2510W	2' x 5'	BAB31010W	3' x 10'
BAB2610W	2' x 6'	BAB31210W	3' x 12'
BAB2810W	2' x 8'	BAB31510W	3' x 15'
BAB21010W	2' x 10'	BAB32010W	3' x 20'
BAB21210W	2' x 12'	BAB4610W	4' x 6'
BAB21410W	2' x 14'	BAB4810W	4' x 8'
BAB21510W	2' x 15'	BAB41010W	4' x 10'
BAB22010W	2' x 20'	BAB41510W	4' x 15'
BAB3410W	3' x 4'	BAB42010W	4' x 20'
BAB3510W	3' x 5'	BAB42510W	4' x 25'
BAB3610W	3' x 6'		

Custom Made Banners

Same or Next Day!

S&F has real clout when it comes to supplying your banner needs, top quality 10 oz. vinyl, 13 oz. or 15 oz., any custom special banner same or next day.



Bandana Banner On The Roll

Just peel off what you need!



Banner on the roll is a fabric with heat sealed edges and double grommet feature every 24" for easy use.



ITEM #	COLOR	SIZE	WEIGHT
BAB2224Y	Yellow	22" x 24 yds	11.5oz
BAB3424Y	Yellow	34" x 24 yds	11.5oz
BAB4624Y	Yellow	46" x 24 yds	11.5oz
BAB2224R	Red	22" x 24 yds	11.5oz
BAB4624R	Red	46" x 24 yds	11.5oz
BAB4624BL	Blue	46" x 24 yds	11.5oz
BAB4624W	White	46" x 24 yds	11.5oz
BAB2224W	White	22" x 24 yds	14oz
BAB3424W	White	34" x 24 yds	14oz
BAB462414W	White	46" x 24 yds	14oz
AB4624BK	Black	46" x 24 yds	14oz

BestBanner



ITEM NO.	SIZE	WEIGHT	FINISH
BA1030FL-G	30" x 120'	10oz.	Gloss
BA1030FL-M	30" x 120'	10oz.	Matte
BA1038FL-G	38" x 120'	10oz.	Gloss
BA1038FL-M	38" x 120'	10oz.	Matte
BA1054FL-G	54" x 120'	10oz.	Gloss
BA1054FL-M	54" x 120'	10oz.	Matte
BA1062FL-G	62" x 120'	10oz.	Gloss
BA1062FL-M	62" x 120'	10oz.	Matte
BA1338FL-G	38" x 120'	13oz.	Gloss
BA1338FL-M	38" x 120'	13oz.	Matte
BA1354FL-G	54" x 120'	13oz.	Gloss
BA1354FL-M	54" x 120'	13oz.	Matte
BA1362FL-G	62" x 120'	13oz.	Gloss
BA1362FL-M	62" x 120'	13oz.	Matte

Taracloth Rolls

All purpose, ultra smooth, 100% Polyflax sign cloth for use with most types of paint, ink, enamel, vinyl letters and graphics. Triple coated. Not intended for high wind areas.



STOCK#	LENGTH	WIDTH
CLTC3612	12 yd.	36"
CLTC3648	48 yd.	36"
CLTC3660	60 yd.	36"
CLTC36100	100 yd.	36"
CLTC5212	12 yd.	52"
CLTC5248	48 yd.	52"
CLTC5260	60 yd.	52"
CLTC52100	100 yd.	52"

Tyvek

Strong, lightweight, smooth, low linting, opaque and resistant to water, chemicals, abrasion & aging.



ITEM NO.	SIZE
BATV3625	36" x 25 yd.
BATV3650	36" x 50 yd.
BATV6025	60" x 25 yd.
BATV6050	60" x 50 yd.

Metallic Streamers

Made from brilliant metallic plastic, mounted on extra-heavy, poly-plastic rope. Stocked in Gold, Silver & assorted colors. Length – 60'

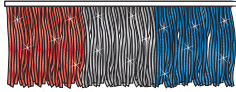

ITEM NO.	COLORS
BAPMA	Silver, Red, Orange, Blue, Green
BAPMG	Gold
BAPMS	Silver

Pennants

105 ft. long, made of 4 gauge polyethylene. Double sewn on plastic covered sag resistant nablom.



ITEM NO.	COLOR
BAPF	Multi Color
BAPFRWB	Red / White / Blue
BAPFRWG	Red / White / Green

Nylon Vertical Message Flags

With canvas header and brass grommets. Size: 3' x 5'

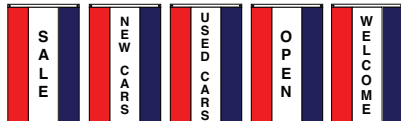

ITEM NO.	DESCRIPTION
	MODEL
	NEW CARS
	USED CARS
	OPEN
BANMFS	SALE
	WELCOME

Weatherized Cloth Grand Opening Banner



- Double sewn on heavy rope.
- 5' ties on each end.
- Made of heavy duty weatherized cloth.
- Colors in bright fluorescent red, blue, white and Yellow.

ITEM NO.	SIZE
BACLG035	3' x 5'
BACLG0310	3' x 10'

Plastic Grand Opening Banner

Made of easy wipe durable waterproof plastic.



ITEM NO.	SIZE
BAGOP	3' x 3'

Pleated Cotton Fans

With canvas header, brass grommets, and stars.



ITEM NO.	SIZE
BAPCFWS	3'x6'

Poly Cotton Illusion Fans

With canvas header, brass grommets, and stars.



ITEM NO.	SIZE
BAPCIF	3'x5'

Plastic Ties

ITEM NO.	SIZE	COLOR
LYPT4BK	4"	Black
LYPT4N	4"	Natural
LYPT7BK	7"	Black
LYPT7N	7"	Natural



ITEM NO.	SIZE	COLOR
LYPT11BK	11"	Black
LYPT11N	11"	Natural

Banner Accessories

Pole Banner Kit

Use this special Pole Banner Kit to display banners on city light poles, parking lots, shopping centers and more.

Pole brackets available in pairs of single or double poles. Designed to display banners up to 36" wide.

4 metal straps 36" included with each pair.

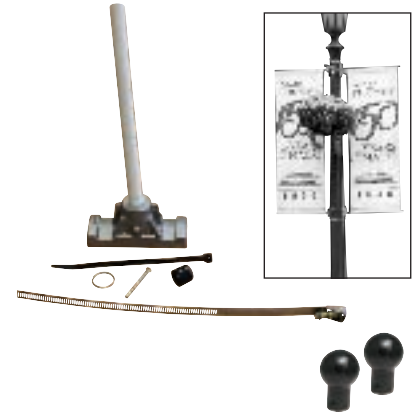

ITEM NO.	DESCRIPTION
BAPBK24BK	24" Single Banner Kit Black
BAPBK36BK	36" Single Banner Kit Black
BAPBK24M	24" Single Banner Kit Mill
BAPBK36M	36" Single Banner Kit Mill
BAPS	Strap for Pole Bracket
BAPBDBKBK	Black Decorative Ball Cap (2)

Can't find a product?

If you don't see a particular product in our catalog, please give us a call. We will help you get it. Also, please note that some products not listed might be available as a special order.



Banner Accessories

Grommet Hole Cutter #500



ITEM NO.	SIZE
AWGHC5000	#0A
AWGHC5001	#1A
AWGHC5002	#2A
AWGHC5003	#3A
AWGHC5004	#4A
AWGHC5005	#5A
AWGHC5006	#6A

Grommet Insetting Die No. 216



Sets plain rim washers and grommets. 2-part set.

ITEM NO.	SIZE
AWGHC2160	#0
AWGHC2161	#1
AWGHC2162	#2
AWGHC2163	#3
AWGHC2164	#4
AWGHC2165	#5
AWGHC2166	#6

Grommet Insetting Die No. 216



Top part only

ITEM NO.	SIZE
AWGHC2162T	#2

Grommet Insetting Die No. 217

Sets spur washers and grommets.

ITEM NO.	SIZE
AWGHC2170	#0
AWGHC2171	#1
AWGHC2172	#2
AWGHC2173	#3
AWGHC2174	#4
AWGHC2175	#5
AWGHC2176	#6
AWGHC2177	#7
AWGHC2178	#8

Rawhide Mallet #196-3



The head of this light-weight mallet is made entirely of rolled water buffalo rawhide. Handle is white hickory.

ITEM NO.	SIZE	DIA. OF FACE
AWGHC1963	3	1 3/4

Cutting Pad No. 603

Made of a special formula resilient vinyl plastic, for use with Punches. They are long wearing and can be used on both sides.

ITEM NO.	SIZE
AWGHC603	10 x 10 x 1/2

Rawhide Split Head Hammer No. 395

Ideal for use with grommet dies and whenever a cushioned blow is desired. No trouble to replace faces. Just loosen the safety nut, remove the worn face, insert replacement and tighten.

ITEM NO.	SIZE	LENGTH OF HEAD	DIA. OF FACE
AWGHC3951R	1	3 3/4	1 1/4
AWGHC3952R	2	4 1/4	1 1/2
AWGHC3953R	3	4 3/4	1 3/4

Stimpson Model 405 Bench Press Grommet Machine

Used extensively in many businesses for setting eyelets, grommets and washers and snaps, the 405 has now become the popular choice for setting self-piercing grommets and washers in most lightweight fabrics.

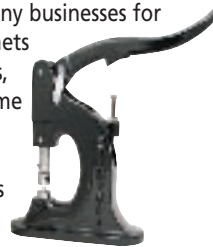

ITEM NO.	
AWGHS405A	Grommet Machine
AWGHSPNS2	Die Punch Only

Stimpson Co. Inc.

Sheet Metal Brass Grommets



One gross equals 144 sets.

ITEM NO.	SIZE	GROSS
AWGSM0B1	#0	1
AWGSM0B25	#0	25
AWGSM1B1	#1	1
AWGSM1B25	#1	25
AWGSM2B1	#2	1
AWGSM2B25	#2	25
AWGSM2B50	#2	50
AWGSM3B1	#3	1
AWGSM3B25	#3	25
AWGSM4B1	#4	1
AWGSM5B1	#5	1
AWGWSM2B1	#2 Washers only	1

For grommet dimensions, see page 133

Nickle Plated Grommets



ITEM NO.	SIZE	GROSS
AWGSM0N1	#0	1
AWGSM1N1	#1	1
AWGSM2N1	#2	1
AWGSM2N25	#2	25
AWGSM3N1	#3	1

Grommet Kit #2

Includes hole cutter, punch and grommets.



ITEM NO.	SIZE	QUANTITY
AWGHG71260	#0 (1/4")	24 Sets
AWGHG71262	#2 (3/8")	12 Sets
AWGHG12602	#2 (3/8")	24 Sets
AWGHG71264	#4 (1/2")	12 Sets

Bench Mount Press Grommet Machine

For Self Piercing Grommets. No. 2 Die Included



ITEM NO. AWGHM2

Self Piercing Grommets

No 2. grommets. 500 per bag.

ITEM NO. AWGSP2B500

Banner Accessories



Pres-N-Snap Tool

Presenting the versatile and easy to use Pres-N-Snap. Capable of setting numerous brands of fasteners simply by changing the dies. Its heat-treated cast-aluminum body makes it both lightweight and durable. Pres-N-Snap and all its components are manufactured in the USA.



ITEM NO.	DESCRIPTION
AWGHPNSTOOL	Pres-N-Snap Tool
AWGHPNSPLUNGER	Plunger
AWGHPNSHANDLE	Handle
AWGHPNSLEVER	Lever
AWGHPNSSPRING	Spring
AWGHPNSNUT	Nut & Bolt
AWGHPNSBOLT	Adjusting Bolt
AWGHPNSORING	Small "O" Ring 6227-5
AWGHPNSSTDRING	Stud "O" Ring #N012
AWGHPNSRUBRET	M2700 Gray ring
AWGHPNSMOUNT	Bench Mount

Grommet Die Set

For Pres-N-Snap Tool



Standard Grommet

ITEM NO.	SIZE
AWGHPNS00DIE	#00 (3/16" ID)
AWGHPNS0DIE	#0 (1/4" ID)
AWGHPNS1DIE	#1 (5/16" ID)
AWGHPNS2DIE	#2 (3/8" ID)

Spur Grommet

ITEM NO.	SIZE
AWGHPNS0SPUR	#0 (1/4" ID)
AWGHPNS1SPUR	#1 (5/16" ID)

Hole Punch

For Pres-N-Snap Tool

ITEM NO.	SIZE
AWGHPNS00HOLE	#00 (3/16" ID)
AWGHPNS0HOLE	#0 (1/4" ID)
AWGHPNS1HOLE	#1 (5/16" ID)
AWGHPNS2HOLE	#2 (3/8" ID)

Items on this page require a two day lead time, FOB Philadelphia, PA



PM5 Bench Mount Press

The PM5 machine is an industry standard bench-mounted machine. It is made of tough ductile iron and has a deep throat with a longer padded handle. This machine uses standard 3/8" diameter shank dies that set self-piercing grommets up to size 300 (#4), and snap fasteners in one motion, swiftly and efficiently.



ITEM NO. MAHDFMACHPM5AL

Electric Foot Press

Fasnap's electric foot press machine offers an economical and convenient means of fastener attachment. The machine sets snap fasteners, rivets and grommets up to size #3 and use the same dies as the standard PM5 bench-mounted machine. Throat depth 4". This machine is also available in a pneumatic model.



ITEM NO. MAHDFMS025SDS38

Grommet Die

For PM5 Bench Mount or Electric Foot Press.

Standard Die

ITEM NO.	SIZE
MAHDFDIES210PM5	#0
MAHDFDIES230PM5	#1
MAHDFDIES250PM5	#2
MAHDFDIES280PM5	#3
MAHDFDIES300PM5	#4

Spur Die

ITEM NO.	SIZE
MAHDFDISSPUR0	#0
MAHDFDISSPUR2	#2
MAHDFDISSPUR4	#4

Self-Piercing Grommets

Fasnap's premium self-piercing grommets are manufactured with a sharpened edge for superior piercing ability. The washers are made with a patented design that incorporates small teeth and a channel to prevent slipping and provide extra holding force.



Brass

ITEM NO.	SIZE	QUANTITY
MAHDFGRMGWS210B	#0	500
MAHDFGRMGWS230B	#1	500
MAHDFGRMGWS250B	#2	500
MAHDFGRMGWS280B	#3	100
MAHDFGRMGWS300B	#4	100

Nickel

ITEM NO.	SIZE	QUANTITY
MAHDFGRMGWS210N	#0	500
MAHDFGRMGWS230N	#1	500
MAHDFGRMGWS250N	#2	500
MAHDFGRMGWS280N	#3	100

Stainless Steel

Designed to withstand the harshest environments, our stainless steel self-piercing rolled rim grommets with spur washers are the best product available for corrosive applications.

ITEM NO.	SIZE	QUANTITY
MAHDFGRMWSPUR4S	#4	500

Banner Accessories

Items on this page require a two day lead time, FOB Philadelphia, PA

Stimpson
Co. Inc.

Rolled Rim Grommets w/Spur Washers

Rolled Rim Grommets and Spur Washers are available in many sizes in brass and zinc, with some sizes also offered in stainless steel. These parts interlock, their teeth grasping the material, to provide a rugged, unyielding setting. Available in brass, nickel and dull black chemical finishes.



ITEM NO.	SIZE	FINISH	GROSS
AWGSP0B1	#0	Brass	1
AWGSP0B25	#0	Brass	25
AWGSP0N1	#0	Nickel	1
AWGSP0N25	#0	Nickel	25
AWGSP1B1	#1	Brass	1
AWGSP1B25	#1	Brass	25
AWGSP1N1	#1	Nickel	1
AWGSP1N25	#1	Nickel	25
AWGSP2B1	#2	Brass	1
AWGSP2B25	#2	Brass	25
AWGSP2N1	#2	Nickel	1
AWGSP2N25	#2	Nickel	25
AWGSP3B1	#3	Brass	1
AWGSP3B25	#3	Brass	25
AWGSP3N1	#3	Nickel	1
AWGSP3N25	#3	Nickel	25
AWGSP4B1	#4	Brass	1
AWGSP4B25	#4	Brass	25
AWGSP4N1	#4	Nickel	1
AWGSP5B1	#5	Brass	1
AWGSP5B25	#5	Brass	25
AWGSP5N1	#5	Nickel	1
AWGSP6B1	#6	Brass	1
AWGSP6N1	#6	Nickel	1
AWGSP7B1	#7	Brass	1
AWGSP8B1	#8	Brass	1
AWGSP8N1	#8	Nickel	1

Washers Only

ITEM NO.	SIZE	FINISH	GROSS
AWGWSP0B5	#0	Brass	5
AWGWSP1B5	#1	Brass	5
AWGWSP2B5	#2	Brass	5
AWGWSP3B5	#3	Brass	5
AWGWSP4B5	#4	Brass	5
AWGWSP5B5	#5	Brass	5

Stimpson
Co. Inc.

Sheet Metal Grommet w/Plain Washer

Sheet metal grommets can be used interchangeably with plain, teeth or neck washers. Plain washers offer basic reinforcement, providing support for the grommet setting.



ITEM NO.	SIZE	FINISH	GROSS
AWGSM00B1	#00	Brass	1
AWGSM00B25	#00	Brass	25
AWGSM00N1	#00	Nickel	1
AWGSM00N25	#00	Nickel	25
AWGSM0N25	#0	Nickel	25
AWGSM1B25	#1	Brass	25
AWGSM1N1	#1	Nickel	1
AWGSM1N25	#1	Nickel	25
AWGSM3N25	#3	Nickel	25
AWGSM4B25	#4	Brass	25
AWGSM4N1	#4	Nickel	1
AWGSM4N25	#4	Nickel	25
AWGSM5B25	#5	Brass	25
AWGSM5N1	#5	Nickel	1
AWGSM5N25	#5	Nickel	25
AWGSM6B1	#6	Brass	1
AWGSM6B25	#6	Brass	25
AWGSM6N1	#6	Nickel	1

Washers Only

ITEM NO.	SIZE	FINISH	GROSS
AWGWSM00B5	#00	BRASS	5
AWGWSM00N5	#00	NICKEL	5
AWGWSM0B5	#0	BRASS	5
AWGWSM0B25	#0	BRASS	25
AWGWSM0N5	#0	NICKEL	5
AWGWSM1N5	#1	NICKEL	5
AWGWSM1B5	#1	BRASS	5
AWGWSM2B5	#2	BRASS	5
AWGWSM2N5	#2	NICKEL	5
AWGWSM3B1	#3	BRASS	1
AWGWSM3B5	#3	BRASS	5
AWGWSM3N5	#3	NICKEL	5
AWGWSM4B5	#4	BRASS	5
AWGWSM4N5	#4	NICKEL	5
AWGWSM5B5	#5	BRASS	5
AWGWSM5N5	#5	NICKEL	5

Stimpson
Co. Inc.

Sheet Metal Grommet w/Teeth Washer

Sheet metal grommets can be used interchangeably with plain, teeth or neck washers. Teeth washers offer a firmer, tighter grasp than plain washers, particularly in woven materials.



ITEM NO.	SIZE	FINISH	GROSS
AWGTE0B1	#0	Brass	1
AWGTE1B1	#1	Brass	1
AWGTE2B1	#2	Brass	1
AWGTE2B25	#2	Brass	25
AWGTE2N1	#2	Nickel	1
AWGTE3B1	#3	Brass	1
AWGTE4B1	#4	Brass	1
AWGTE4B25	#4	Brass	25
AWGTE5B1	#5	Brass	1

Washers Only

ITEM NO.	SIZE	FINISH	GROSS
AWGWTE0B5	#0	Brass	5
AWGWTE1B5	#1	Brass	5
AWGWTE2B5	#2	Brass	5
AWGWTE3B5	#3	Brass	5
AWGWTE4B5	#4	Brass	5
AWGWTE5B5	#5	Brass	5

Stimpson
Co. Inc.

Sheet Metal Grommet w/Neck Washer

Sheet metal grommets can be used interchangeably with plain, teeth or neck washers. Neck washers create a telescoping, barrel-to-barrel setting which reinforces the hole with two entire parts.



ITEM NO.	SIZE	FINISH	GROSS
AWGSM1B25N	#1	Brass	25

Stimpson
Co., Inc.

Grommet & Washer Dimensions

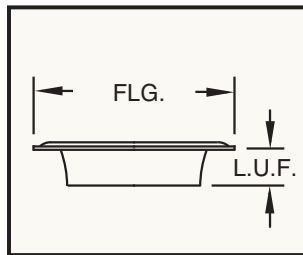

Sheet Metal Grommet

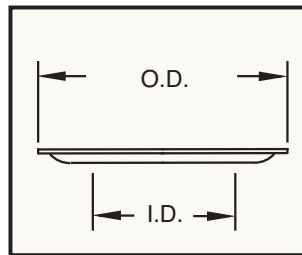

Plain Washer

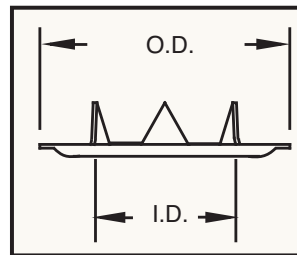

Teeth Washer

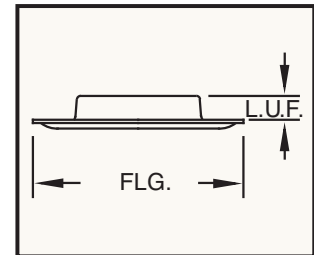

Neck Washer

L.U.F. = Length Under Flange FLG. DIA. = Flange Diameter I.D. = Inside Diameter
O.D. = Outside Diameter MT = Metal Thickness

Sheet Metal Grommet Dimensions

GROMMET	HOLE SIZE	FLG. DIA.	L.U.F.	MT
#00	3/16"	.425	.135	.009
#0	1/4"	.545	.175	.012
#1	9/32"	.687	.185	.012
#2	3/8"	.815	.215	.013
#3	7/16"	.970	.295	.014
#4	1/2"	1.050	.375	.016
#5	5/8"	1.220	.330	.016
#6	13/16"	1.750	.232	.020



Rolled Rim Grommet Dimensions

GROMMET	HOLE SIZE	FLG. DIA.	L.U.F.	MT
#0	9/32"	.670	.175	.016
#1	13/32"	.790	.205	.016
#2	7/16"	.890	.255	.018
#3	15/32"	.970	.255	.020
#4	9/16"	1.120	.320	.020
#5	5/8"	1.285	.380	.021
#6	3/4"	1.535	.420	.025
#7	29/32"	1.725	.446	.020
#8	1-3/32"	1.865	.465	.025



Plain Washer Dimensions

WASHER	I.D.	O.D.	MT
#00	.218	.460	.009
#0	.289	.546	.010
#1	.359	.700	.012
#2	.453	.835	.012
#3	.530	.955	.013
#4	.585	1.062	.013
#5	.740	1.205	.0135
#6	.875	1.828	.020



Spur Washer Dimensions

WASHER	I.D.	O.D.	MT
#0	.345	.645	.016
#1	.455	.790	.016
#2	.512	.890	.018
#3	.537	.970	.020
#4	.645	1.120	.020
#5	.777	1.270	.021
#6	.875	1.505	.025
#7	1.062	1.725	.020
#8	1.195	1.910	.020



Teeth Washer Dimensions

WASHER	I.D.	O.D.	MT
#0	.290	.570	.0115
#1	.350	.680	.014
#2	.468	.840	.012
#3	.545	.945	.013
#4	.593	1.050	.016
#5	.720	1.190	.017



Neck Washer Dimensions

WASHER	FLG. DIA.	L.U.F.	MT
#00	.425	.125	.010
#0	.531	.100	.010
#1	.705	.105	.010
#2	.840	.095	.013
#3	.945	.125	.014
#4	1.050	.125	.015



Hole Size is the approximate measurement after setting. All dimensions are in inches.

Banner Accessories



The Quick, Strong, And Inexpensive Alternative To Grommets.

Banner Ups® White Tabs with Loop

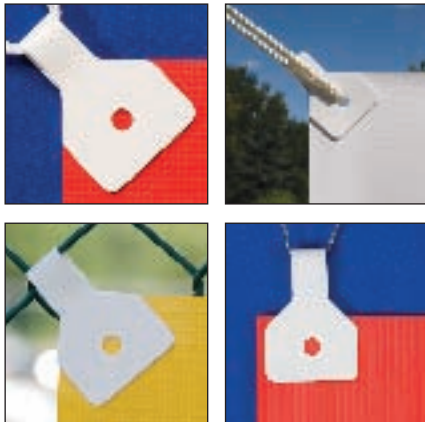

- Make your own banner blanks instantly. No special tools required.
- Banner Ups® withstood sustained winds of 50-70 miles per hour!
- Sticks to virtually all common banner media including scrim vinyl, Tyvek®, Valeron®, polyethylene, polypropylene, Foamcore®, Coroplast®, and many others.
- Tab Size: 2.0" x 5.75"
- 20 per pack

ITEM NO. BAC-UPSW

PowerPunch™ Hole Cutter Tool



A heavy duty hand-held punch. Cuts cleanly through Banner Ups PowerTabs®, PowerTape®, and heavy duty banner substrates. The tool will cut substrates up to 1/8" thick. Replaceable punch for long life. Hole size: 5/16"

ITEM NO.	DESCRIPTION
BAC-PUNCH	Hole Cutter Tool
BAC-PTBMW	Replacement Punch

PowerTabs®

PowerTabs® are less conspicuous than grommets and blend into the banner substrate for a more pleasing visual effect. They are available in regular size for outdoor banners, mini size for indoor or light duty outdoor use. Available in white, and now in crystal clear for full-color digital banners.



PowerTab with Loop

Tab Size: 2.125" x 5.5"

Use Neck loop for light duty conditions or center whole when more strength is needed.

ITEM NO.	COLOR	PACK
BAC-PTBW	White	20
BAC-PTBC	Clear	20

PowerTab Mini

Tab Size: 1.5" x 3.125"

ITEM NO.	COLOR	PACK
BAC-PTBMW	White	25
BAC-PTBMC	Clear	25

EdgeTabs Crystal-Clear Tab w/Loop

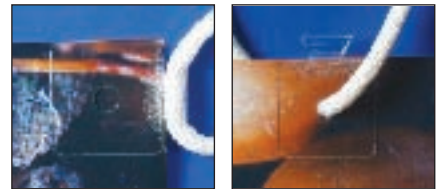

A crystal-clear tab to use along the edges of banners when additional fastening points are desired. Their rectangular shape also looks great on corners making them a "one size fits all" tab for medium-duty banners.

ITEM NO. BAC-ETB

PowerTape® Hem Reinforcing Tape

Use PowerTape instead of double-sided banner tape or sewing to reinforce banner edges. Single-sided super strong film, no need to fold hem. Lets you create a super-strong outdoor banner of any length in less than one fifth the time of traditional methods. Also great for preventing banner edge curl on banner stand.



ITEM NO. BAC-PTP



Apply PowerTab

Apply Power Tape

Punch Hole

Polymatic Bonded Monocord Thread

Size: 125
Put up: 16 oz. Spools



ITEM NO.	COLOR
AWTR125BK-16	Black
AWTR125BR-16	Brown
AWTR125BUR-16	Burgundy
AWTR125COBL-16	Cobalt Blue
AWTR125FGR-16	Forest Green
AWTR125NBL-16	Navy Blue
AWTR125OR-16	Orange
AWTR125RED-16	Red
AWTR125WHT-16	White
AWTR125YEL-16	Yellow

Polymatic Belbobs Bonded Monocord

80 bobbins/box, 22yd ea.
Size: 125
Style: G



ITEM NO.	COLOR
AWTRBOB125-BK	Black
AWTRBOB125-BR	Brown
AWTRBOB125-BUR	Burgundy
AWTRBOB125-COBL	Cobalt Blue
AWTRBOB125-FGR	Forest Green
AWTRBOB125-NBL	Navy Blue
AWTRBOB125-OR	Orange
AWTRBOB125-RED	Red
AWTRBOB125-WHT	White
AWTRBOB125-YEL	Yellow

Webbing

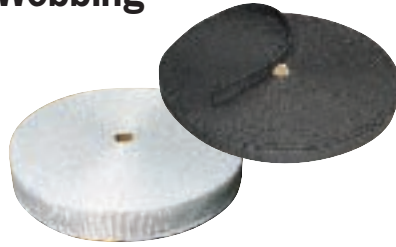

ITEM NO.	SIZE	COLOR
AWWPP2B	2" x 300'	Black
AWWPP2W	2" x 300'	White
AWWPP1BK	1" x 300'	Black
AWWPP1W	1" x 300'	White

Solid Braid Nylon Awning Rope

Solid Braided sash cord type nylon cord, one of the strongest and most durable cords made. Nylon stretches to absorb shock. It is mildew-proof, allowing it to be stored when wet.



Larger sizes are ideal for anchor ropes, awning cords, flag halyards, mooring lines, sash cord, sheet rope, tarpaulin tie down ropes and many other purposes that require great strength and durability.

ITEM NO.	SIZE	LENGTH
AWRP4	#4 (1/8")	1000'
AWRP6	#6 (3/16")	1000'
AWRP8	#8 (1/4")	500'
AWRP10	#10 (5/16")	1000'

Banner Accessories

Metal Slip Fit Balls

(Gold or Silver)



Z-1

Fits our 1" inside diameter metal poles.

ITEM NO.	COLOR	HEIGHT	BALL
BAMPB2	Gold	3"	2"

Z-138

Fits our 1 1/4" inside diameter metal poles.

ITEM NO.	COLOR	HEIGHT	BALL
BAMPB212	Gold	4"	2 1/2"

Metal Parade Balls

No ferrule or spindle.
Fits 1" poles.



ITEM NO.	SIZE	COLOR
BAMPB3G	3"	Gold
BAMPB3S	3"	Silver

Plastic Pole Balls

ITEM NO.	SIZE	COLOR
BAMPB138	1-3/8"	Gold

Double-Faced Polyester Film Tape

Clear with High-tac acrylic adhesive. In the sign industry it is used for hemming banners.



ITEM NO.	THICKNESS	WIDTH	LENGTH
LYDFSHT14	5 mil	1/4"	72 yd
LYDFSHT12	5 mil	1/2"	72 yd
LYDFSHT34	5 mil	3/4"	72 yd
LYDFSHT1	5 mil	1"	72 yd

Wrapping Seminar

At a wrapping seminar hosted by S&F. Please inquire about our upcoming seminars.



Banner Accessories

Pro Klip Banner Clip

An amazing instant, reusable banner clip. No more drilling or grommets required. The harder you pull, the stronger it grips. Fastens instantly to virtually any material. 12 pack.

Comes in two sizes:

Pro Klip Small

Designed for banner material. The rope or hook used to hang the banner pulls on the wedge such that: The greater the pull, the stronger the grip.



Pro Klip Medium

Designed for thicker materials, such as 4mm Coroplast or 3mm Sintra. Pro Klip Medium uses a ratchet design to fasten itself to the material.



ITEM NO.	SIZE
BAC-EKS	Small
BAC-EKM	Medium

O Rings



ITEM NO.	SIZE
HDOR34	3/4"
HDOR1	1"
HDOR112	1-1/2"

D Rings



ITEM NO.	SIZE
HDDR34	3/4"
HDDR1	1"

Snap Hook



Wide throat snap-hooks are widely used in awning vinyl drops. Attach to D-Rings. Nickel plated.

ITEM #
HDSNH1

Hanging Clips

5 pack

ITEM NO. HDHC3



Quick Link Connectors

5 pack

ITEM NO.	SIZE
HDQLC14	1/4" x 2-1/8"
HDQLC18	1/8" x 1-1/8"
HDQLC36	3/16" x 2"



Suction Cups



ITEM NO.	SIZE	DIAMETER
LYSCSM	Small (1lb.)	1 1/8"
LYSCM	Medium (3lb.)	1 3/4"
LYSCLG	Large (7lb.)	2 3/8"

Digital Graphics Showrooms

Our showrooms are always set up with the latest models of plotters, large format printers, laminators etc. Our trained technicians are ready to give you a free demonstration on any of the equipment.

Please call to schedule an appointment.



Retractable Banner Stands

Sizes reflect the image size that will display. Banner installation instructions can be downloaded from our website www.sfsupplies.com

Econo Retractable Banner Stand

Compact and lightweight aluminum casing with two twist out feet for added stability. Quick and easy assembly in seconds. Easy to install banner, just snap the aluminum profile to the top of the banner, then attach the bottom of the banner to the plastic leader with the adhesive strip. Carrying bag included.



ITEM NO.	SIZE
BADISER33	33½" x 79"

Ultra Retractable Single Side Banner Stand

This is the flagship model of retractable banner stands. With the click of a button, you can change the banner without any tools. Easy installation of banner with the snap profile for the top of the banner and the snap roller for the bottom. Telescopic pole lets you adjust the graphics to required height size.

The wide base design and adjustable feet allow the display to stand firmly and straight on uneven floors. Chrome-plated end caps make your display stand out from the others. Carrying bag included.

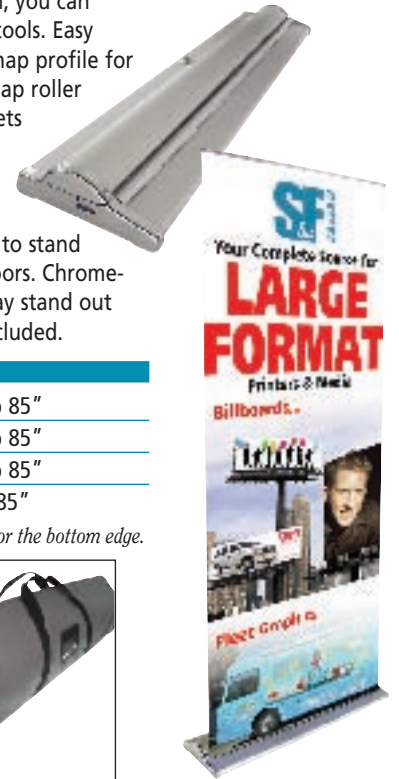

ITEM NO.	SIZE
BADISUR33	33½" x up to 85"
BADISUR39	39¾" x up to 85"
BADISUR47	47¼" x up to 85"
BADISUR59	59" x up to 85"

Add an additional 8" to the banner for the bottom edge.

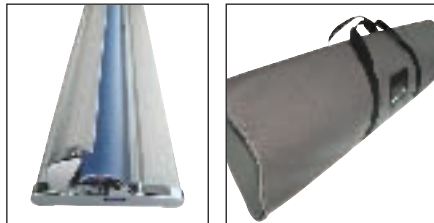

Silver Banner Stand

Your ultimate choice for a light weight, compact and convenient banner stand at an affordable price. Easy to install banner, just snap the aluminum profile to the top of the banner, then attach the bottom of the banner to the plastic leader with the adhesive strip. Carrying bag included.



ITEM NO.	SIZE
BADISSR23	23¾" x 63"
BADISSR33	33½" x 79"
BADISSR39	39¾" x 79"
BADISSR47	47¼" x 79"

Add an additional 2" to the banner for the bottom edge.



Dual Retractable Double Side Banner Stand

Same features as the "Ultra" but has a double cassette for displaying 2 banners. Deluxe carrying case included.



ITEM NO.	SIZE
BADISDR33	33½" x 85"
BADISDR39	39¾" x 85"

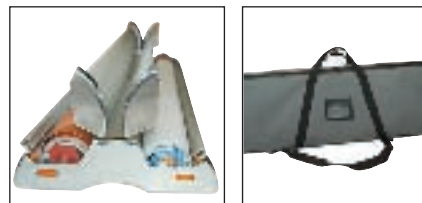

Banner Stands

Sizes reflect the image size that will display. Banner installation instructions can be downloaded from our website www.sfsupplies.com

EZDisplay Banner Stand

Light-weighted and budget priced makes EZDisplay the perfect choice when it comes to volume order. User-friendly and easy to mount. Uses snap profiles for top and bottom of banner.

The graphic extends to the edge of the display making it possible to put them together with no gap between them. Use the optional banner lock (not included) to keep them together. Great for creating a graphic back wall.

Carrying bag included.

ITEM NO.	SIZE
BADISED23	23" x 71"
BADISED33	33½" x 85"
BADISED39	39" x 85"
BADISED47	47¼" x 85"



EzDisplay



BACK VIEW

TriLeg Banner Stand

High quality and elegant design banner stand. The main frame with 3 integrated feet forms a stable and convenient display, with no parts to loose. Can be used at various heights with the telescopic pole which allows easy height adjustment up to 85" high. Uses snap profiles for top and bottom of banner.

Can also be used as a two sided banner stand with an additional set of the Aluminum Snap Profile (not included).

Carrying bag included.

ITEM NO.	SIZE
BADISTL23	23" x up to 85"
BADISTL31	31½" x up to 85"
BADISTL39	39" x up to 85"



TriLeg



Banner Stand Accessories

Banner Light

With this Banner Light, your display will stand out without any extra efforts. Easy to install - simply clamp onto the banner pole and plug in, you are ready to go!

Fits all our retractable or non-retractable banner stands. The clamping lock on each light fits our banner pole perfectly. Carrying case included.

ITEM NO. BADISBLI



Banner Lock

Use the optional banner lock for the EZDisplay Banner Stand. When using multiple stands to create a graphic back wall, this lock will keep them together.

ITEM NO. BADISBLO



Aluminum Snap Profile

These aluminum snap profiles are available in different widths to replace profiles used in all our banner stands (except for the Econo).

ITEM NO.	SIZE	ITEM NO.	SIZE
BADISASP23	23"	BADISASP39	39"
BADISASP31	31½"	BADISASP47	47¼"
BADISASP33	33½"	BADISASP59	59"

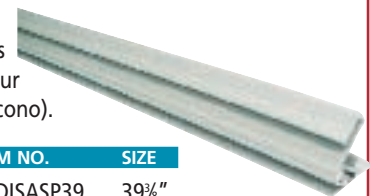

Telescopic Banner Pole

These are the same poles found in our Ultra and Dual retractable banner stands. Also great for use with the Silver retractable and EZDisplay banner stand. The telescopic pole will allow you to adjust the banner to any required height size.

ITEM NO. BADISBP





www.sfsupplies.com



INDEX

DIGITAL MEDIA	5
SIGN VINYL	45
VINYL AND WRAP SUPPLIES	59
WIDE FORMAT EQUIPMENT	73
VINYL CUTTERS	87
ENGRAVERS	95
SOFTWARE	97
SUBSTRATES	105
BANNER	127
SIGN DISPLAY	139
Steel Frames	140-141
Plastic Sign Frames & Stakes	142
Extruded Plastic Display	143-144
Sign Display	144
TAPES & ADHESIVES	145
PAINT	153
NEON SUPPLIES & EQUIPMENT	167
TRANSFORMERS	207
LED SYSTEMS	229
LIGHTING & ELECTRIC	243
SIGN EXTRUSION	267
LETTER & ACCESSORIES	277
MOUNTING HARDWARE	281
EQUIPMENT & SHOP TOOLS	293

Steel Sign Stakes

Coro-Stakes

Premier Coro-Stake

Heavy duty with rust proof zinc plating. Made with solid 5/16" rod base to hold up in strong winds. Accepts 4mm coroplast. Black powder coat finish.

10 per box.

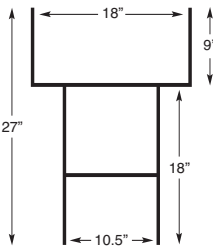

ITEM NO.	STAKE SIZE
CPS-PR	18Wx27H

EZ Coro-Stake

General purpose stand with out rust proof zinc plating made with a solid non-flexing 1/4" rod base. Accepts 4mm coroplast. Black powder coat finish.

25 per box.

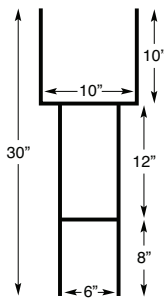

ITEM NO.	STAKE SIZE
CPS-HD41030	10Wx30" H

Coro-Stake SS1

Light duty stake made with a sturdy 3/16" rod base. Rust proof zinc plating. Economical stand designed to be used with 4mm coroplast.

50 per box.

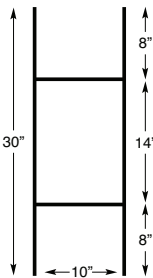

ITEM NO.	STAKE SIZE
CPS-SS41030	10Wx30" H

Coro-Stake 8mm

For use with 10mm Coroplast Blanks.

ITEM NO.	STAKE SIZE
CPS-8MM	10Wx30" H

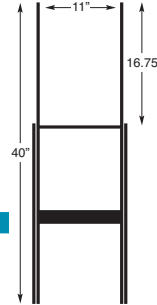

Heavy Duty Coro-Stake

For use with 8-10mm Coroplast Blanks.

ITEM NO.	STAKE SIZE
CPS-SS101130	11Wx30" H

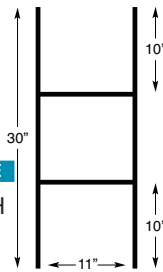

Heavy Duty Coro-Stake

For use with 8-10mm Coroplast Blanks.

ITEM NO.	STAKE SIZE
CPS-SS101240	12Wx40" H

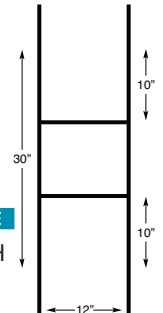

Sign Stakes

U-Stake

Ideal for fold over and fold & staple sign board and bag signs. 9 gauge.

100 per box.

ITEM NO.	SIZE
CPS-U9	20"W x 33"H

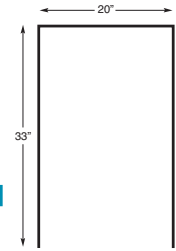

T-Bar Stake

All 3/4" angle stake with a welded foot push and extra strip at the top to give panels additional support. Prepunched holes. Black powder coat finish. 42" tall.

ITEM NO.	HEIGHT
STF-TB42	42"

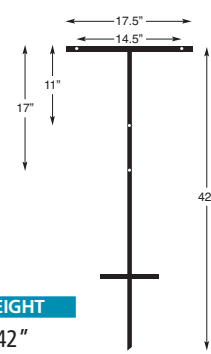

Sign Stake

Sturdy sign holders made of 3/4" angle iron. Welded push bar. Several prepunched holes to bolt panel on. Pointed leg. Back powder coat finish.

ITEM NO.	FRAME SIZE
STF-ST36	36" High
STF-ST48	48" High
STF-ST60	60" High

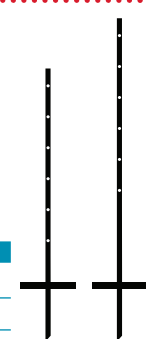

Colonial Swing Post Frame

- All metal Construction. Made in USA!
- 1" Square tube.
- Two piece construction for easy set up.
- Threaded inserts for rider attachment.
- Mounting hardware included.

ITEM NO.	ARM	HEIGHT
STF-CSW28	28"	54"

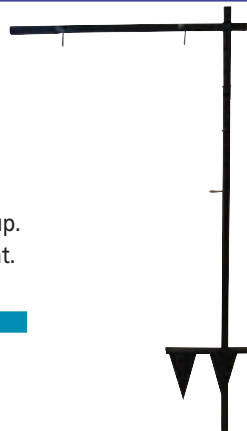

Crane Style Sign Holder

Two part construction for easy installation and handling

ITEM NO.	ARM	HEIGHT
STF-CR24	24"	60"



Steel Sign Frames

Sign Frame

"HR" Style Frame

A robot welded 3/4 angle iron frame with a main panel section and a 6" rider space located below. The frame has rounded corners and spiked legs. Black powder coat finish. Prepunched bolt holes.

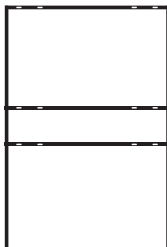

ITEM NO.	FRAME SIZE
STF-HR1824	18"x24"
STF-HR2028	20"x28"
STF-HR2424	24"x24"
STF-HR2436	24"x36"

Double Rider

ITEM NO.	FRAME SIZE
STF-HRDR1824	18"x24"

Diamond Style Frame

Unique Diamond Shape. Panels bolt in securely. Space for a rider panel.

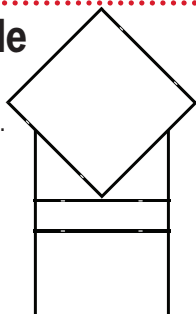

ITEM NO.	SIZE
STF-D2424	24" x 24"

"F" Style Frame

A "Picture Frame" design made of 3/4" angle iron. Black powder coat finish with pointed legs. Rounded corners, no sharp edges.

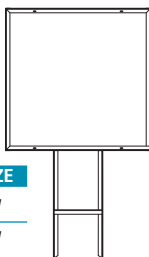

ITEM NO.	FRAME SIZE
STF-F1824	18Hx24W
STF-F2028	20Hx28W

"R" Style Frame

Classic style available with 1/2" or 3/8" slid round side legs and 3/4" wide flat strip crossbars. Pointed legs. Black powder coat finish.

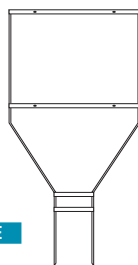

ITEM NO.	FRAME SIZE
STF-R1824	18Hx24W

Folding Frame

Tent Frame

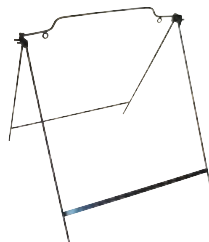

ITEM NO.	SIZE
STF-T2424	18"x24"

Standard Metal Folding Frame

Heavy duty portable frame made of 3/4" angle iron. Hinged on top. Welded carry handle. Holds two panes that bolt into the frame. Folds flat for storage. Black powder coat finish.



ITEM NO.	FRAME SIZE
STF-FF1824	18Hx24W
STF-FF2418	24Hx18W
STF-FF2424	24Hx24W
STF-FF3624	36Hx24W
STF-FF2436	24Hx36W

"A" Frames for Sidewalk Signs

Side loading



ITEM NO.	SIZE
STF-FFSL4832	32" x 48"

Sturdy Steel Construction

Complete "A" board 36"h x 24"w. Sturdy steel construction. Painted White.



ITEM NO.	COLOR
STF-CAB3624W	White

Frame Accessories

Spring Steel Clip

Easy to use clips snap onto any of our 3/4" angle iron frames to hold your panels in place, no nuts or bolts needed. Black oxide finish.



ITEM NO. STF-CLIP

Dual Spring Mounted Flexible Frames

- Designed to bend in strong wind and return to an upright position
- Holds panel 24 x 36", up to 1/2" thick
- Panel slides in from the top and is secured in place by a set screw.



ITEM NO.	THICKNESS	SIZE
STF-FL3624	1/4"	24"x36"

Wind Spinner

Black, Frame only.



ITEM NO.	SIZE
STF-WSP3018BK	30" x 18"

Floor Stand

Size: 22" x 28"

ITEM NO.	COLOR
STF-F52228BK	Black
STF-F52228CH	Chrome
STF-F52228GD	Gold Polished



Plastic Sign Frames & Stakes

Plastic Frame

A-Frame



This is undoubtedly the most versatile A-Frame sign frame in the marketplace. Dual-channel end-cap design accepts 4mm and 6mm corrugated plastic, dry-erase board, PVC, and even plastic-cored aluminum sheet-stock. The unique bungee-style center support makes this capable of capturing a wide range of sign-face sizes all the way from 18" x 24" to 36" x 60" and beyond.

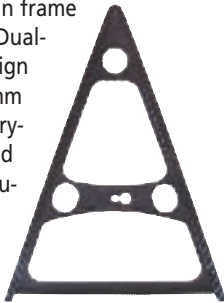

- Accommodates wide range of sign sizes
- Accepts 4 mm and 6 mm substrates
- Includes innovative dual-bungee attachment support

ITEM NO. PLF-AF36

A1A-Frame



This compact yet sturdy patent-pending design echoes the same basic features of the larger A-Frame and can display signs 24" in height and 18" through 36" in width.



The wide 6mm channels and simple bungee-cord elastic strap provides for an exceptionally easy setup. The lower cross-member at the base allows the use of any conveniently available ballast weight.

ITEM NO. PLF-AF24

USA Sign Starter Kit

Use the samples for in-store display, testing, or begin selling them as soon as your kit arrives.

Kit includes:

- (2) USA Step Frames,
- (1) USA Goal Post,
- (4) USA Spider Stakes,
- (3) USA Window Clips,
- (1) USA A-Frame,
- (2) USA A1A-Frames,
- (12) USA Hot-Dog Stands



ITEM NO. PLF-SSKIT

Plastic Yard Signs

Realicade



- Holds 18"H x 24"W Sign
- Rider holds 6" x 24" sign
- Slide in your sign, bolts are optional
- Available in black or white
- 26.75"W x 45.75"H

ITEM NO.	COLOR
PLF-RLC1824BK	Black
PLF-RLC1824W	White

T-Cade

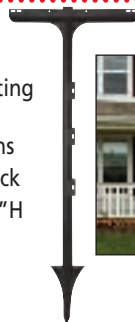

- Multiple Mounting holes to attach various size signs
- Available in black
- 17.25"W x 42.5"H

ITEM NO.	COLOR
PLF-TC42BK	Black

Step Frame



Patent-pending realtor-style sign frame accepts either metal or Coro-Plast 18"x24" substrates that simply slip into place — no sharp edges or screw heads sticking out. Now with a FREE Spider-Rider, so you can add a corrugated rider sign to the top or side in seconds. Black color.

- No fasteners required
- Includes clip-on Spider-Rider

ITEM NO. PLF-R1824BK

Goal Post



Intended to accommodate those eye-catching die-cut dimensional creations, the open-top design of this unique step frame has all the same advantages found in each and every one of our products.

- Die-cut dimensional graphics
- No fasteners required



ITEM NO. PLF-R1824BK

Spider Stake



Sporting a fresh contemporary appearance, our rugged webbed design stands up to the wind and the handy integrated step-peg makes it easy to get the stake into even hard soil. The upper torsion bar design evenly distributes wind loads and faithfully returns the sign back to attention.



- Alternative to H-wires
- Made of recycled plastic
- No sharp edges or screw faces
- light weight and durable
- Use with 4mm corrugated substrates

ITEM NO. PLF-SS4

Car Window Clip



Window Clip is designed for easily sliding on to most any car or truck window. Used by car dealer's. Real estate agents use them to draw attention to the open house they're hosting. These are just a few examples of how this product can be marketed to your customers.

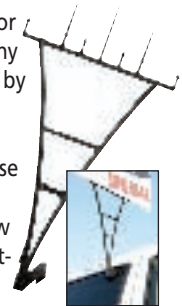

- Clips to car window
- No fasteners required
- Use with 4mm corrugated substrates

ITEM NO. PLF-CS4

Hot-Dog Stand Stake



Designed for simplified indoor table and counter-top display of corrugated plastic or cardboard signage, this compact patent-pending sign stand is simple, effective, and of course, inexpensive.



- 18" x 24" graphics
- Easy slide-in assembly
- Use with 4mm corrugated substrates

ITEM NO. PLF-HDS4

Extruded Plastic Display

Signicade

- Overall Size 25" wide x 45" high
- Sign regress of 24" wide x 36" high
- Patented Locking Hinge – Keeps Signicade Open
- Hole with plug for sand ballasting.
- Flashing lights can attach to all units.
- Free Funnel with every unit



ITEM NO.	COLOR
PLF-SC4525W	White
PLF-SC4525Y	Yellow
PLF-SC4525O	Orange

Squarecade 36

- Overall Size 25" wide x 36" high
- Sign regress of 24" wide x 24" high

ITEM NO.	COLOR
PLF-SQC3625W	White
PLF-SQC3625Y	Yellow

Signicade Deluxe

- **Change signs in seconds**
- Use Coroplast or other material 3/16" or less
- "Stay Tabs" assure sign stays securely in place
- No tape, Velcro, or screws needed
- Internally weight with sand
- Overall size 27" wide x 48 3/8" High.
- Sign display area 24" x 36"



ITEM NO.	COLOR
PLF-SCD4827W	White
PLF-SCD4827BK	Black

Portable Sign Stand

Marquee

- Overall size 26" wide x 41" High.
- Sign display area 24" x 36".
- Easy open handle makes lifting and setup easy.
- Can be ballasted with 5 lbs. of sand per side.

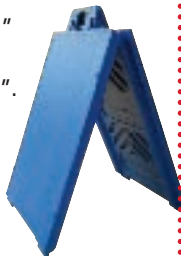

ITEM NO.	COLOR
PLF-M4126BK	Black
PLF-M4126BL	Blue
PLF-M4126GR	Green
PLF-M4126RD	Red

Marquee Junior

Perfect for those narrow sidewalks where a narrow sign is needed for advertising products or company. It can even be used as a simple WELCOME on one side and GOOD BYE on the other.

- Overall size 14" wide x 41" high
- Weight 9 lbs
- Sign area is 12" x 36"



ITEM NO.	COLOR
PLF-MJR4114W	White
PLF-MJR4114Y	Yellow

Minicade

The Minicade is fantastic for school crossing, narrow advertising spaces like shopping malls, and narrow sidewalks.

- Molded in hollow plastic for internal ballasting with sand – Incredibly Durable
- Hinges click-lock in open position
- Brackets for flashing light available



ITEM NO.	COLOR
PLF-MNC3613W	White
PLF-MNC3613Y	Yellow

SimpoSign

- Holds 22"W x 28"H sign
- Molded-in Handle Assures Easy Portability
- Regressed Sign Faces Protect the Sign Legends
- High Density Polyethylene Assures No Rust, Splinters, Discoloration or Maintenance



ITEM NO.	COLOR
----------	-------

SimpoSign II

- **Change signs in seconds**
- Blanks quickly slide in and out and stay securely in place
- Regressed sign face is 22" by 28", the standard dimension for all retail signs
- One Frame – Many Signs



ITEM NO.	COLOR
PLF-SSIIW	White Granite

Extruded Plastic Display • Sign Display

Wind Sign

- Springs connect the frame to the base allowing sign to resist strong winds and return to upright position.
- "Quick change" feature enables sign blanks to be changed in seconds.
- Sand or water fillable plastic base.
- Attractive plastic frame design
- Two-sided. Can accommodate coroplast, aluminum, acrylic, or any foamboard.



ITEM NO.	COLOR
PLF-WS2822GY	28" x 22"
PLF-WS3624GY	36" x 24"

Sidewalk Sign

- 24" x 36" sign blanks quickly slide in and out and stay securely in place.
- Outrigger feet can be filled with sand or water.
- Molded-in tie down hole.



ITEM NO.	COLOR
PLF-SWS3624BK	Black
PLF-SWS3624W	WHITE GRANITE

Can't find a product?

if you don't see a particular product in our catalog, please give us a call. We will help you get it. Also, please note that some products not listed might be available as a special order.

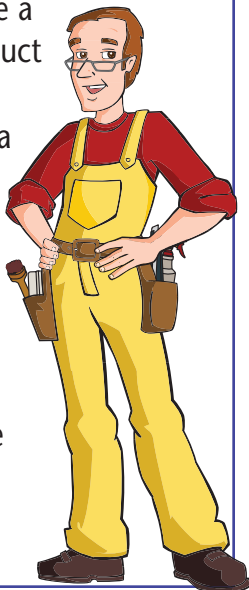

Deluxe Scroll Bracket

- "Twisted" steel shaft
- Solid cast iron ball finial
- Mounts to post or wall
- Heavy duty 3/16" back plate with four mounting holes (5/16" dia.)

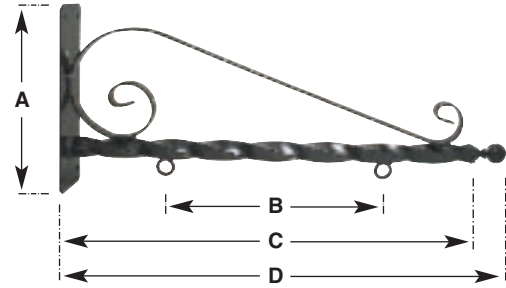

ITEM NO.	SIZE	(A) PLATE HEIGHT	(B) HOLE CENTER	(C) TWISTED SHAFT	(D) OVERALL SIZE
STF-DSCB24	24"	12"	14"	26"	28.5"
STF-DSCB36	36"	14"	22"	38"	40.5"
STF-DSCB48	48"	14"	30"	50"	52.5"

Message Board

- Coroplast Message Board Kits come with tracks permanently attached. Two boards per kit. Available in white (with black letters and red numbers and headers) or black (with white letters and fluorescent red numbers and headers).
- Letter sets contain over 350 letters and numbers, plus "Sale" and "Special" Headers.
- Screws included for attaching boards to Signicade and Marquee sign frames.



For Signicade and Marquee

ITEM NO.	COLOR
PLF-MBKIT2436BK	Black
PLF-MBKIT2436W	White

For Wind Sign

ITEM NO.	COLOR
PLF-MBKIT2840W	White

For SimpoSign & SimpoSign II

ITEM NO.	COLOR
PLF-MBKIT2228W	White

Cabbie Taxi Top Signs

Now any business or independent entrepreneur can increase sales and customer brand awareness by using Portable Cartop Signs. Make money while driving your car...it's that simple.

Cartop Signs are completely assembled and ready to use, including; 10' Lighter Adapter, replaceable 3-bulb light system. Neo-Magnets with red SoftShoe scratch-proof Covers.



Cabbie I



Cabbie II



Cabbie XL

Three models available:

Cabbie I, Cabbie II and Cabbie XL

ITEM NO.	SIZE (HxWxL)
ECABBIE-I	10.75" x 9.63" x 22.13"
ECABBIE-II	11.5" x 9.5" x 22.13"
ECABBIE-XL	12" x 11.38" x 26.63"
ECA-CP	Cigarette Plug Adapter Cord



www.sfsupplies.com



INDEX

DIGITAL MEDIA	5
SIGN VINYL	45
VINYL AND WRAP SUPPLIES	59
WIDE FORMAT EQUIPMENT	73
VINYL CUTTERS	87
ENGRAVERS	95
SOFTWARE	97
SUBSTRATES	105
BANNER	127
SIGN DISPLAY	139
TAPES & ADHESIVES	145
Double Sided Tape.....	146
Hook & Loop	147
Sign Making Adhesive.....	147-152
PAINT	153
NEON SUPPLIES & EQUIPMENT	167
TRANSFORMERS	207
LED SYSTEMS	229
LIGHTING & ELECTRIC	243
SIGN EXTRUSION	267
LETTER & ACCESSORIES	277
MOUNTING HARDWARE	281
EQUIPMENT & SHOP TOOLS	293

Double Sided Tape

Double-Sided Paper Tape

Double Coated Paper Tape #410B

Utilizes a natural rubber adhesive system that offers good to excellent adhesion to many types of surfaces.



ITEM NO.	THICKNESS	WIDTH	LENGTH
LY3M410B1236	5 mil	1/2"	36 yd
LY3M410B3436	5 mil	3/4"	36 yd
LY3M410B136	5 mil	1"	36 yd

Double-Sided Foam Tape

Double Coated Foam Tapes

Open cell urethane foam flexible carrier with high shear, high temperature resistant acrylic adhesive. Use to fill gaps and bond irregular surfaces. Distributes stress uniformly over bonded area.



#4008 1/8", #4016 1/16", #4032 1/32"

ITEM NO.	THICKNESS	WIDTH	LENGTH
LY3M4008347	1/8"	3/4"	7 yd
LY3M40083436	1/8"	3/4"	36 yd
LY3M4008136	1/8"	1"	36 yd
LY3M40161236	1/16"	1/2"	36 yd
LY3M40163415	1/16"	3/4"	15 yd
LY3M40163436	1/16"	3/4"	36 yd
LY3M4016136	1/16"	1"	36 yd
LY3M40321272	1/32"	1/2"	72 yd
LY3M40323472	1/32"	3/4"	72 yd
LY3M4032172	1/32"	1"	72 yd

Double-Faced Foam Tape

Acrylic adhesive for exterior permanent use.



ITEM NO.	THICKNESS	WIDTH	LENGTH
LYDD1321272	1/32"	1/2"	72 yd
LYDD1323472	1/32"	3/4"	72 yd
LYDD132172	1/32"	1"	72 yd
LYDD1161236	1/16"	1/2"	36 yd
LYDD1163436	1/16"	3/4"	36 yd
LYDD116136	1/16"	1"	36 yd

VHB™ Double-Sided Foam Tape

VHB™ Foam Tape 4950 White

45.0 mil, thick white closed cell acrylic foam carrier with all purpose acrylic adhesive and paper liner. High strength, handling convenience, cushioning, damping and impact resistance. UL listing 746C.



ITEM NO.	THICKNESS	WIDTH	LENGTH
LY3M49501236	45 mil	1/2"	36 yd
LY3M49503436	45 mil	3/4"	36 yd
LY3M4950136	45 mil	1"	36 yd

VHB™ Foam Tape 4910 Clear

40.0 mil, clear closed cell acrylic foam carrier with film liner and an acrylic adhesive. Use to join transparent material and replace rivets, screws and other mechanical fasteners.



ITEM NO.	THICKNESS	WIDTH	LENGTH
LY3M49101236	40 mil	1/2"	36 yd
LY3M49103415	40 mil	3/4"	15 yd
LY3M49103436	40 mil	3/4"	36 yd
LY3M4910136	40 mil	1"	36 yd

VHB™ Tape Conformable Foam 4941 Gray

This double sided foam tape utilizes multi-purpose acrylic adhesive on both sides of conformable foam. The adhesive provides excellent adhesion to a broad range of high and medium surface energy substrates including metals, glass, and a wide variety of plastics, as well as plasticized vinyl. The conformable foam provides good contact, even with mismatched substrates.



Also available in black.

ITEM NO.	THICKNESS	WIDTH	LENGTH
LY3M49413436	45 mil	3/4"	36 yd

Adhesive Transfer Tape

VHB™ Adhesive Transfer Tape F-9473PC Clear

10 mil (0.25 mm) clear acrylic adhesive with 58 lb polycoated kraft paper liner. High shear strength, solvent and temperature resistance and HSE, low LSE, UL listing 746C.



ITEM NO.	THICKNESS	WIDTH	LENGTH
LY3M94731260	10 mil	1/2"	60 yd
LY3M94733460	10 mil	3/4"	60 yd
LY3M9473160	10 mil	1"	60 yd
LY3M9473260*	10 mil	2"	60 yd
LY3M9473460*	10 mil	4"	60 yd

* Available as special order

Adhesive Transfer Tape 465 Clear

2.0 mil, 400 high tack acrylic adhesive with 3.8 mil, 60 lb densified kraft paper liner. Medium temperature and solvent resistance, medium HSE and low LSE. Flexible to minus 60 degrees F with excellent adhesion to most paper stocks.



ITEM NO.	THICKNESS	WIDTH	LENGTH
LY3M4652460	2 mil	24"	60 yd

Other sizes available upon request

Double-Faced Polyester Film Tape

Clear with High-tac acrylic adhesive.



ITEM NO.	THICKNESS	WIDTH	LENGTH
LYDFSHT1472	5 mil	1/4"	72 yd
LYDFSHT1272	5 mil	1/2"	72 yd
LYDFSHT3472	5 mil	3/4"	72 yd
LYDFSHT172	5 mil	1"	72 yd

Hook & Loop • Sign Making Adhesive

Hook & Loop

Hook & Loop sold separately.
Available for sew-on or
with pressure-sensitive.



Hook P.S.A. 75' Rolls

ITEM NO.	WIDTH	COLOR
AWHPSA58WHT	5/8"	White
AWHPSA58BK	5/8"	Black
AWHPSA75WHT	3/4"	White
AWHPSA75BK	3/4"	Black
AWHPSA1WHT	1"	White
AWHPSA1BK	1"	Black
AWHPSA150WHT	1-1/2"	White
AWHPSA2WHT	2"	White
AWHPSA2BK	2"	Black

Loop P.S.A. 75' Rolls

ITEM NO.	WIDTH	COLOR
AWLPSA58WHT	5/8"	White
AWLPSA58BK	5/8"	Black
AWLPSA75WHT	3/4"	White
AWLPSA75BK	3/4"	Black
AWLPSA1WHT	1"	White
AWLPSA1BK	1"	Black
AWLPSA150WHT	1-1/2"	White
AWLPSA2WHT	2"	White
AWLPSA2BK	2"	Black

Hook Sew-On 150' Rolls

ITEM NO.	WIDTH	COLOR
AWHSO1WHT	1"	White
AWHSO1BK	1"	Black
AWHSO2WHT	2"	White
AWHSO2BK	2"	Black

Loop Sew-On 150' Rolls

ITEM NO.	WIDTH	COLOR
AWLSO1WHT	1"	White
AWLSO1BK	1"	Black
AWLSO2WHT	2"	White
AWLSO2BK	2"	Black

Dual Lock™ Reclosable Fasteners

3M™ Dual Lock™ Reclosable Fasteners invisibly attach access doors and panels, signs, display components, and many other frequently removed parts. The mushroom-shaped stems interlock to provide tensile strength high enough to replace mechanical fasteners in many applications. They can be opened and closed hundreds of times. Adhesive-backed versions are available for bonding to bare or painted metal, wood, glass, etc.



ITEM NO.	COLOR	WIDTH	LENGTH
LY3MSJ3560150	Clear	1"	150'

Also available by the foot.

Signboard Adhesive S308

Extreme

Extreme Adhesives® offer these solvent free structural adhesive systems that provide outstanding flexibility, toughness and bond strength for joining many plastics, metals, and composites in any combination.



- Outstanding Toughness and Durability
- Excellent Adhesion to Plastics and Metals
- Extreme Impact Resistance & Extreme Peel Strength
- 100% Reactive Solids Formulation for VOC Compliance and Safety
- 1 : 1 Mix Ratio in Convenient Cartridges

ITEM NO.	DESCRIPTION
EXT-SBA-50ML	50ml cartridge with tip
EXT-SBA-400ML	400ml cartridge with tip

Mixing Tips

EXT-MIX-50ML	for 50ml, 6 Pack
EXT-MIX-400ML	for 400ml, 6 Pack

Dispenser Guns

Dispenser Guns



ITEM NO.	DESCRIPTION
EXT-DK-104	for 50ml cartridge
EXT-VBM-400X	for 400ml cartridge

Conversion Kit

Use a standard dispenser gun for the 50ml cartridges, with this conversion kit.



ITEM NO. EXT-DK-117

Artist's Adhesive Spray Mount

An indispensable tool for artists and crafters Bonds lightweight materials instantly, yet allows work to be lifted and repositioned.



ITEM NO. LY3M6065SA16

Sign Making Adhesive

LORD Product Selector Guide

	ALUMINUM/ STEEL*	PREFINISHED METAL	POLYCARBONATE*	ACRYLIC*	URETHANE FOAM	PVC FOAM BOARD	CERAMIC/ STONE	WOOD
ALUMINUM/ STEEL*	403/19 406/19 410/19	403/19 406/19 410/19	N/A	N/A	7650 7610 7542 7545	403/19 406/19 410/19	320/332°	N/A
PREFINISHED METAL	403/19 406/19 410/19	403/19 406/19 410/19	7542 7545 7610 ^N	7542 7545 7610 ^N	7542 7545 7650 7610	406/19 7542 7545 7650 7610	320/332°	7542 7545 7650
POLYCARBONATE*	N/A	7542 7545 7610	406/19 7542 7545 7610	7542 7545 7610	7542 7545 7650 7610	7542 7545 7650 7610	360 7610 ^N	7542 7545 7650 7610
ACRYLIC*	N/A	7542 7545 7610	7542 7545 7610	406/19 7542 7545 7610	7550 ^N	7542 7545 7650 7610	360 7610 ^N	7542 7545 7650 7610
TRIMCAP	403/19 406/19 410/19	7550 ^N	7550 ^N	7550 ^N	7542 7545 7550 ^N	7542 7545 7650 7610	N/A	7542 7545 7550 ^N
URETHANE FOAM	7660 7610 7542 7545	7542 7545 7650 7610	7542 7545 7650 7610	7542 7545 7650 7610	7542 7545 7550 ^N	7542 7545 7650 7610	7610 ^N	7542 7545 7650 7610
PVC FOAM BOARD	403/19 406/19 410/19	406/19 7542 7545 7650 7610	7542 7545 7650 7610	7542 7545 7650 7610	7542 7545 7650 7610	7542 7545 7650 7610	7610 ^N	7542 7545 7650 7610
CERAMIC/ STONE	320/322°	320/322°	360 7610 ^N	360 7610 ^N	7610 ^N	7610 ^N	320/322 360	7610 ^N 360
WOOD	N/A	7542 7545 7650 7610	7542 7545 7650 7610	7542 7545 7650 7610	7542 7545 7550 ^N	7542 7545 7650 7610	7610 ^N 360	7542 7545 7650 7610
CURED CONCRETE	7610 320/322 360	320/322 360	7610	7610	N/A	N/A	320/322	7610 320/322
GLASS	406/19	406/19	N/A	N/A	N/A	N/A	N/A	N/A

N – For non-structural bonding (assemblies where adhesive is used for aesthetic attachment in minimum stress areas.

* – Coefficient of thermal expansion is a major consideration when cross-bonding these substrates. In addition, indoor or outdoor application will determine adhesive.

∞ – Prepare metal by scuffing/abrading followed by a solvent wipe.

NOTE: LORD 406/19, 403/19, 410/19, and 7542 are all UL recognized.

Sign Making Adhesive

Epoxy Adhesives

LORD

LORD epoxy adhesives create superior bonds for rubber, SMC, plastics and metals. Our epoxy adhesives are widely used in the automotive industry – over 10 million cars and light- and heavy-duty trucks feature body panels bonded with LORD epoxy adhesives.

320/322

Structural epoxy. Bonds a variety of substrates including prepared metals, plastics, wood and prepared rubber. Most effective for bonding concrete, stone and wood.



ITEM NO.	SIZE
LO-320/32250ML	50ml

360A/B

Two-part mix epoxy. Very fast cure.



ITEM NO.	SIZE
LO-360A/B50ML	50ml

Can't find a product?

if you don't see a particular product in our catalog, please give us a call. We will help you get it. Also, please note that some products not listed might be available as a special order.



Urethane Adhesives

LORD

LORD one- and two-part urethane adhesives provide superior bonds with minimal surface preparation for today's high-performance thermosets and thermoplastics. They offer primerless adhesion for sheet molded compounds (SMC) and are ideal for prepared metals, rubber and fiber reinforced plastics (FRP).

7542A/B

FRP, SMC, other thermoset plastics, prepared metals and wood. Use for bonding plastics or painted metal to plastic.



ITEM NO.	SIZE
LO-7542A/B50ML	50ml

7550A/C

For bonding trimcap (especially trimcap to polycarbonate).



ITEM NO.	SIZE
LO-7550A/C50ML	50ml

7660

One-part, crosslinking structural adhesive. For FRP, SMC, BMC, other plastics and prepared metals; other laminating and trim components; crosslinking contact cement and wood



ITEM NO.	SIZE
LO-76601/2PT	1/2 Pint

Acrylic Adhesives

LORD

LORD acrylic adhesives are versatile and can be used with a wide range of materials, including minimally prepared or unprepared metal surfaces. LORD acrylic adhesives are 2-part systems that use accelerators to cure.

403/19

Bonds bare metals, plastics and composites. Very fast cure. Use for bonding brackets, set-offs, hinges and small parts. Non-sag.



ITEM NO.	SIZE
LO-403/1950ML	50ml

406/19

Standard product for all metal plastics and composites bonding. Use for sign boxes, corner angles, raceways, metal letters, retainers, Alcan Composites and other ACMs to aluminum, Sintra® to aluminum. Non-sag.



ITEM NO.	SIZE
LO-406/1950ML	50ml

406/19 with Glass Beads

ITEM NO.	SIZE
LO-406/19GL375M	375ml

410/19 with Glass Beads

ITEM NO.	SIZE
LO-410/19GL375M	375ml

Dispenser Guns & Components

LORD

ITEM NO.	DESCRIPTION
LO-GUN-375ML	Dispenser Gun for 375ml
LO-GUN-50ML	Dispenser Gun for 50ml
LO-MIX-375ML	Mixing tip for 375ml
LO-MIX-50ML	Mixing tip for 50ml
LO-PLUNGER/1:1	50ml Universal Plunger 1:1



Sign Making Adhesive

WELD-ON Product Selector Guide

	ABS	ACRYLIC CELL CAST	ACRYLIC CROSS-LINKED	ACRYLIC EXTRUDED	BUTYRATE	CONCRETE	FIBERGLASS	METAL	PETG	POLY-CARBONATE	POLY-URETHANE POLYESTER	PVC (RIGID)	PVC (FLEXIBLE)	PVC (FOAMED)	STYRENE	WOOD	
ABS	2354 1707/4707 55/58	16 1802 40/42	10 40/42	16 1802 40/42	16 55/58 40/42	10 45	10 45	45 10	16 55/58 40/42	16 55/58 40/42	40/42 10 4784 55/58	66 4784 16 4052	10 45	45 40/42 45	16 1802	16 4052 10	45
Acrylic Cell Cast	16 1802 40/42	40/42 3/4 16	10 40/42	40/42 3/4 16	16 40/42 45	10 45	10 45	10 45	10 40/42 16	16 40/42 45	40/42 10 4784	66 16 4052	45	16 40/42 45	16 4052 10	45	
Acrylic Cross-Linked	10 40/42	10 40/42	10 40/42	10 40/42	40/42 10 45	10 45	10 45	10 45	10 40/42 45	10 40/42 45	40/42 10 10	40/42 10 45	45	40/42 45	10 40/42	10 45	
Acrylic Extruded	16 1802 40/42	40/42 3/4 16	10 40/42	40/42 3/4 16	16 40/42 45	10 45	10 45	10 45	10 40/42 16	10 40/42 45	40/42 10 4784	66 16 4052	45	16 40/42 45	16 4052 10	45	
Butyrate	16 55/58 45/40/42	16 40/42 45	40/42 10 45	16 40/42 45	3/2007 16 55/58	10 45	10 45	45 10	16 55/58 40/42	16 55/58 40/42	40/42 10 45	66 4784 55/58	16 4784 45	66 4784 45	66 40/42 45	1802 16 45	45 10
Concrete	10 45	10 45	10 45	10 45	10 45	10 45	10 45	10 45	10 45	10 45	10 45	10 45	45	10 45	10 45	10 45	
Fiberglass	10 45	10 45	10 45	10 45	10 45	10 45	10 45	10 45	10 45	10 45	10 45	10 45	45	10 45	10 45	10 45	
Metal	45 10	10 45	10 45	10 45	45 10	10 45	10 45	10 45	10 45	10 45	10 45	10 45	45	45 10	10 45	10 45	
PETG	16 55/58 40/42	10 40/42 16	10 40/42 45	10 40/42 16	16 55/58 40/42	10 45	10 45	10 45	55/58 3/4 40/42	55/58 40/42 45	40/42 45	10	10 40/42 16	45	16 40/42 45	16 10	45
Polycarbonate	16 55/58 40/42	16 40/42 45	10 40/42 45	10 40/42 45	16 55/58 40/42	10 45	10 45	10 45	55/58 40/42 45	55/58 3/4 16	40/42 10 45	10	40/42 10 16	45	16 40/42 45	10 16 1802	45
Polyester	40/42 10	40/42 10	40/42 10	40/42 10	40/42 10 45	10 45	10 45	10 45	40/42 45	40/42 10 45	40/42 10 1829	10	40/42 10	45	10 40/42 45	10 1829	
Polyurethane	66 4784 55/58	66 4784	40/42 10	66 4784	66 4784 55/58	10	10	10	10	10	10 1829	66 4784 55/58	66 4784 45	66 4784	66 4784	10 45	45
PVC (Rigid)	10 16/4052 45	40/42 16 4052	10 40/42 45	40/42 16 4052	16 55/58 40/42	10 45	10 45	10 45	10 40/42 16	40/42 10 16	40/42 10	66 4784	2007 10/40/42 1007/4007	2007 45	16 2007 40/42/45	10 16 1802	45
PVC (Flexible)	45	45	45	45	66 4784 45	45	45	45	45	45	45	66 4784 45	2007 45	2007 66/4784 45	2007 45	2007 45	45
PVC (Foamed)	16 40/42 45	16 40/42 45	40/42 45	16 40/42 45	16 40/42 45	10 45	10 45	45 10	16 40/42 45	16 40/42 45	10 40/42 45	66 4784	16 2007 40/42/45	2007 45	2007 16 40/42/45	1802 16 45	45 10
Styrene	16 1802	16 4052 10	10 40/42	16 4052 10	1802 16 45	10 45	10 45	10 45	16 10	10 16 1802	40/42 10	10 45	10 16 1802	2007 45	1802 16 45	4807 16 1802	45
Wood	45	45	10 45	45	45 10	10 45	10 45	10 45	45	45	10 1829	45	45	45	45	45	45



Sign Making Adhesive

Acrylic Adhesives

WELD-ON



WELD-ON #3

Non-flammable, water thin, very fast-setting solvent cement for bonding acrylics. Also bonds styrene, butyrate, PETG, and polycarbonate to themselves. Will not bond to cross linked acrylics.

ITEM NO.	SIZE	COLOR
WO3G	Gallon (Glass Bottle)	Clear
WO3PT	Pint	Clear
WO3Q	Quart	Clear

WELD-ON #4

Non-flammable, water thin, moderately fast-setting solvent cement for bonding acrylics. Also bonds styrene, butyrate, PETG, and polycarbonate to themselves. Will not bond to cross linked acrylics.

ITEM NO.	SIZE	COLOR
WO4G	Gallon (Glass Bottle)	Clear
WO4PT	Pint	Clear
WO4Q	Quart	Clear

WELD-ON #16

Fast-setting, medium bodied, high strength acrylic cement. Also bonds rigid PVC, ABS, styrene, butyrate, polycarbonate to themselves and each other, as well as other plastics and porous surfaces.

ITEM NO.	SIZE	COLOR
WO16MT5	5 oz. (Metal Tube)	Clear
WO16G	Gallon	Clear
WO16PT	Pint	Clear

Vinyl Adhesives

WELD-ON



WELD-ON #66

Thin-bodied, fast-curing, versatile contact cement for use on flexible vinyl, leather, urethane, wood, and canvas.

ITEM NO.	SIZE	COLOR
WO66G	Gallon	Clear
WO66PT	Pint	Clear

WELD-ON #1007

Thin-bodied, very fast-setting cement for bonding rigid vinyl, foamed PVC, and Kydex

ITEM NO.	SIZE	COLOR
WO1007PT	Pint	Clear

WELD-ON #4052

Low VOC multipurpose, medium-bodied cement for bonding PVC, CPVC, ABS, styrene, Noryl®, and foamed PVC.

ITEM NO.	SIZE	COLOR
WO4052G	Gallon	Amber

Polycarbonate Adhesive

WELD-ON #55, **WELD-ON** 2-Part Cartridge

VOC-free, two part, slow-setting, reactive, urethane-based adhesive for bonding polycarbonate, butyrate, ABS, and PETG to themselves and each other. Excellent UV light resistance.

ITEM NO.	SIZE
WO55C	2-Part Cartridge, 50ml
WO55TIP	Mixing Tip for 50ml

Structural Adhesives

Weld-On Structural Adhesives series are very versatile and can be used with many dissimilar materials. The two-component reactive system (base resin and activator) ensures strong, consistent bonds, particularly between metals, composites, and thermoplastics.

WELD-ON

WELD-ON #10

Two-component, high strength, high viscosity structural adhesive for bonding PVC, acrylic, ABS, and polycarbonate. Also bonds well to steel, non-anodized aluminum, other metals, etc.



Available in two sizes:

Gallon = 1 Gallon Part A, 1 Pint Part B

Pint = 1 Pint Part A, 2 Oz. Part B

ITEM NO.	SIZE	COLOR
WO10G	2-Part, Gallon/Pint	White
WO10PT	2-Part, Pint/2oz.	White

WELD-ON #45, 2-Part Cartridge

WELD-ON

Two-part, high strength, reactive structural adhesive for bonding aluminum, galvanized steel, brass, copper, ABS, PVC, CPVC, PETG, polycarbonate and foam board to themselves and each other.



ITEM NO.	SIZE	COLOR
WO45C-400	2-Part, 400ml	Offwhite
WO45C	2-Part, 50ml	Offwhite

Dispenser Guns & Components

ITEM NO.	DESCRIPTION
WO45DG	Dispenser Gun for #45, 50ml
WO45DG-400	Dispenser Gun for #45 400ml
WO55DG	Dispenser Gun for #55
WOMT-11651	Mixing Tip for 400ml
WO55TIP	Mixing Tip for 50ml

WELD-ON



Sign Making Adhesive

Spray Adhesives

Super 77™ Multipurpose Adhesive



An extremely versatile, fast-drying adhesive that bonds a wide range of lightweight materials. Its fast, aggressive tack and low soak-in make it ideal for projects all around your home or business. It forms strong bonds with everything from paper, cardboard, fabric and cushion foam to plastic, metal, wood and much more.



ITEM NO. LY3M77SA24

Aerove C8177 Multipurpose Adhesive

For general bonding of materials to painted or unpainted surfaces. Quick drying, colorless, and flexible for adhesion to smooth and rough surfaces.



ITEM NO. VASC8177

Hi-Strength 90 Spray Adhesive



A very strong, fast-drying, contact-like adhesive, ideal for bonding decorative laminates. Use for bonding polyethylene and polypropylene to wood, metal and other materials.



ITEM NO. LY3M90SA

Aerove C8190 Hi-Strength Adhesive

This heavy duty adhesive offers a tough web spray formula which provides a fast-tacking and high bond strength product.



ITEM NO. VASC8190

Adhesive Remover



Adhesive Remover - Citrus Base

Adhesive remover for clean-up of over spray and adhesive build up. Fresh citrus scent.



ITEM NO. VAR604024

Aerove Adhesive Remover C8141

A non-chlorinated adhesive remover with citrus oil that also removes grease and grime from a variety of surfaces. Safe on most plastics and metals.



ITEM NO. VARC8141

Silicone Construction Grade

GE construction grade silicone. 10.1 oz tubes.



ITEM NO.	DESCRIPTION
PCS1001	Clear
PCS1002	White
PCS1003	Black
PCS1009	Aluminum
PCS1097	Bronze

Silicone Caulking Gun

ITEM NO. PCSGUN



Resin Bond

Methylene chloride bonding material.



ITEM NO.	DESCRIPTION
PCRNBG	Gallon
PCRNBQ	Quart

Hypo Applicator

ITEM NO.	DESCRIPTION
PCAP	HYPO 25 (Blue)



Weldwood Contact Cement



Premium quality, brush grade, neoprene-based contact cement that meets the stringent requirements of the professional user. High strength and initial grab make it ideal for most projects.

ITEM NO.	SIZE
TSCCG	Gallon
TSCCQ	Quart

Rubber Cement

A liquefied, natural rubber adhesive used for permanent and temporary bonds. Applies smoothly and easily. It is very forgiving and easily cleaned up. Used primarily for art, craft, and graphic activities.



ITEM NO.	SIZE
TSRCQ	Quart
TSRCG	Gallon

Gorilla Glue

For bonding dissimilar surfaces, both indoors and outdoors. Whether you are building, creating or repairing, Gorilla Glue is tough and strong and can help you get the job done right.



ITEM NO.	SIZE
TSGG18	18 oz.
TSGG8	8 oz.

Elmer's Glue



America's favorite all-purpose glue. Perfect for school projects, crafts, and light home repair. Works on a variety of materials.

ITEM NO.	SIZE
TSEGG	Gallon

Elmer's Ultimate Glue

The ultimate adhesive...adheres anything to anything with a permanent, strong, waterproof bond. Requires no mixing and is sandable, paintable and stainable.



ITEM NO.	SIZE
TSGG2	2 oz.



www.sfsupplies.com



INDEX

DIGITAL MEDIA	5
SIGN VINYL	45
VINYL AND WRAP SUPPLIES	59
WIDE FORMAT EQUIPMENT	73
VINYL CUTTERS	87
ENGRAVERS	95
SOFTWARE	97
SUBSTRATES	105
BANNER	127
SIGN DISPLAY	139
TAPES & ADHESIVES	145
PAINT	153
Lettering	154-155
Bulletin	155-158
Primers & Clear Coatings	159
Paints, Additives & Reducers	160
Thinners.....	161
Matal Sign Paint.....	162-163
Brushes & Rollers.....	163,166
Paint Supplies.....	164
Spray Paint	165-166
NEON SUPPLIES & EQUIPMENT	
TRANSFORMERS	
LED SYSTEMS	
LIGHTING & ELECTRIC	
SIGN EXTRUSION	
LETTER & ACCESSORIES	
MOUNTING HARDWARE	
EQUIPMENT & SHOP TOOLS	

Lettering

Lettering Enamel

Lettering Enamels are oil based, superior quality high gloss enamels for interior or exterior use on metal, glass, wood, masonite, MDO and enamel receptive banner & vinyl materials. Intended for sign writing on store fronts, vehicles and wherever fine lettering work is desired.



		GALLON	QUART	PINT
	DESCRIPTION	ITEM NO.	ITEM NO.	ITEM NO.
	100-L Vermillion	P100LG	P100LQ	P100LP
	101-L Lettering White	P101LG	P101LQ	P101LP
	102-L Fire Red	P102LG	P102LQ	P102LP
	103-L Polar White	P103LG	P103LQ	P103LP
	104-L Bright Red	P104LG	P104LQ	P104LP
	108-L Maroon	P108LG	P108LQ	P108LP
	109-L Metallic Gold	P109LG	P109LQ	P109LP
	110-L Metallic Copper	P110LG	P110LQ	P110LP
	111-L Metallic Brass	P111LG	P111LQ	P111LP
	114-L Medium Brown	P114LG	P114LQ	P114LP
	115-L Dark Brown	P115LG	P115LQ	P115LP
	116-L Ivory	P116LG	P116LQ	P116LP
	117-L Tan	P117LG	P117LQ	P117LP
	118-L Chamois	P118LG	P118LQ	P118LP
	120-L Coral	P120LG	P120LQ	P120LP
	124-L Orange	P124LG	P124LQ	P124LP
	130-L Primrose Yellow	P130LG	P130LQ	P130LP
	132-L Lemon Yellow	P132LG	P132LQ	P132LP
	134-L Chrome Yellow	P134LG	P134LQ	P134LP
	142-L Emerald Green	P142LG	P142LQ	P142LP
	143-L Process Green	P143LG	P143LQ	P143LP
	144-L Medium Green	P144LG	P144LQ	P144LP

		GALLON	QUART	PINT
	DESCRIPTION	ITEM NO.	ITEM NO.	ITEM NO.
	148-L Dark Green	P148LG	P148LQ	P148LP
	149-L Aqua	P149LG	P149LQ	P149LP
	150-L Blue Green	P150LG	P150LQ	P150LP
	151-L Robin Egg Blue	P151LG	P151LQ	P151LP
	152-L Light Blue	P152LG	P152LQ	P152LP
	153-L Process Blue	P153LG	P153LQ	P153LP
	154-L Peacock Blue	P154LG	P154LQ	P154LP
	155-L Reflex Blue	P155LG	P155LQ	P155LP
	156-L Brilliant Blue	P156LG	P156LQ	P156LP
	157-L Kansas City Teal	P157LG	P157LQ	P157LP
	158-L Dark Blue	P158LG	P158LQ	P158LP
	160-L Violet	P160LG	P160LQ	P160LP
	161-L Proper Purple	P161LG	P161LQ	P161LP
	162-L Purple	P162LG	P162LQ	P162LP
	163-L Magenta	P163LG	P163LQ	P163LP
	164-L Dark Magenta	P164LG	P164LQ	P164LP
	165-L Rubine Red	P165LG	P165LQ	P165LP
	168-L Salmon Pink	P168LG	P168LQ	P168LP
	191-L Imitation Gold	P191LG	P191LQ	P191LP
	193-L Metallic Silver	P193LG	P193LQ	P193LP
	195-L Medium Gray	P195LG	P195LQ	P195LP
	199-L Black	P199LG	P199LQ	P199LP

Lettering • Bulletin

Poster Colors

An alkyd-resin, oil based paint suitable for show card writing, paper signs, interior murals, displays and set decoration; 1 Shot Art and Sign Poster Colors provide superior, single stroke coverage, excellent flow characteristics and a dead-flat finish when dry. Eliminates color and sheen variations, even with multiple stroke applications, and will not wrinkle papers or card stocks.



		GALLON	QUART	PINT
	DESCRIPTION	ITEM NO.	ITEM NO.	ITEM NO.
	3000 White	P3000G	P3000Q	P3000P
	3001 Light Yellow	P3001G	P3001Q	P3001P
	3002 Chrome Yellow	P3002G	P3002Q	P3002P
	3003 Orange	P3003G	P3003Q	P3003P
	3004 Fire Red	P3004G	P3004Q	P3004P
	3005 Bright Red	P3005G	P3005Q	P3005P
	3006 Magenta	P3006G	P3006Q	P3006P
	3007 Purple	P3007G	P3007Q	P3007P
	3008 Dark Blue	P3008G	P3008Q	P3008P
	3009 Light Blue	P3009G	P3009Q	P3009P
	3010 Blue Green	P3010G	P3010Q	P3010P
	3012 Light Green	P3012G	P3012Q	P3012P
	3013 Dark Green	P3013G	P3013Q	P3013P
	3014 Brown	P3014G	P3014Q	P3014P
	3016 Ultra Blue	P3016G	P3016Q	P3016P
	3099 Black	P3099G	P3099Q	P3099P

Alkyd Flattening Paste



ITEM NO.	SIZE
PRFPQ	Quart
PRFPG	Gallon

Ron-Glo Fluorescent Colors



Ron-Glo Fluorescent Colors are solvent-based lead free flat colors formulated for the graphics arts industry. They are designed for use on properly primed white substrates that require high visibility paint such as signs, painted bulletins, exhibits, safety & aviation markings etc.

		GALLON	QUART
	DESCRIPTION	ITEM NO.	ITEM NO.
	RG01 Blue	PRGF01	PRGF01Q
	RG02 Cerise	PRGF02	PRGF02Q
	RG03 Flame Orange	PRGF03	PRGF03Q
	RG04 Flame Red	PRGF04	PRGF04Q
	RG05 Green	PRGF05	PRGF05Q
	RG06 Lime Yellow	PRGF06	PRGF06Q
	RG07 Red	PRGF07	PRGF07Q
	RG08 Shock Pink	PRGF08	PRGF08Q
	RG09 Sun Yellow	PRGF09	PRGF09Q
	RG10 Vivid Orange	PRGF010	PRGF010Q
	RGUV UV Absorber	PRGUV	PRGUVQ

Quick Dry Background Enamel



Quick Dry Background Enamels are lead free enamels formulated for production background work where a quick dry finish is required. They are designed to yield a durable, high gloss, weather resistant finish.

	GALLON	QUART
DESCRIPTION	ITEM NO.	ITEM NO.
QD101 White	PRQD101G	PRQD101Q

Also available in colors

Speed Dry Enamel White 4000



Designed as a background enamel when it is desired to apply both the background the lettering/design in the same day. Brushes easily and has excellent hiding power. Available in quarts and gallons.

ITEM NO.	SIZE
P4000Q	1 Quart













Bulletin

Bulletin Color Enamel

Solvent Based

Ronan Bulletin Colors are high quality, high gloss enamels specially formulated for use on signs and billboards. Preferred for larger scale signage, Bulletin Colors are designed for painting backgrounds, lettering copy and graphics. One coat coverage, fast dry, fast cut in and extreme high gloss produce a dazzling, weather resistant finish. Recommended for use on outdoor advertising billboards, metal highway signs, commercial signs. All types of wood, masonite, masonry and metal surfaces.



		GALLON	QUART
	DESCRIPTION	ITEM NO.	ITEM NO.
	B021 Black	PRB021G	PRB021Q
	BF21 Flat Black	PRBF21G	PRBF21Q
	B101 White	PRB101G	PRB101Q
	BF101 Flat White	PRBF101G	PRBF101Q
	B100 Vermillion	PRB100G	PRB100Q
	B102 Fire Red	PRB102G	PRB102Q
	B104 Bright Red	PRB104G	PRB104Q
	B105 Imitation Silver	PRB105G	PRB105Q
	B106 Carmine	PRB106G	PRB106Q
	B107 Imitation Gold	PRB107G	PRB107Q
	B108 Maroon	PRB108G	PRB108Q
	B114 Medium Brown	PRB114G	PRB114Q
	B115 Dark Brown	PRB115G	PRB115Q
	B116 Ivory	PRB116G	PRB116Q
	B124 Medium Orange	PRB124G	PRB124Q
	B125 Bright Orange	PRB125G	PRB125Q
	B130 Primrose Yellow	PRB130G	PRB130Q
	B131 Light Yellow	PRB131G	PRB131Q
	B132 Lemon Yellow	PRB132G	PRB132Q
	B133 Medium Yellow	PRB133G	PRB133Q

		GALLON	QUART
	DESCRIPTION	ITEM NO.	ITEM NO.
	B134 Chrome Yellow	PRB134G	PRB134Q
	B135 Golden Yellow	PRB135G	PRB135Q
	B140 Light Green	PRB140G	PRB140Q
	B142 Emerald Green	PRB142G	PRB142Q
	B143 Process Green	PRB143G	PRB143Q
	B144 Medium Green	PRB144G	PRB144Q
	B145 Phthalo Green	PRB145G	PRB145Q
	B148 Dark Green	PRB148G	PRB148Q
	B150 Blue Green	PRB150G	PRB150Q
	B152 Light Blue	PRB152G	PRB152Q
	B153 Phthalo Blue	PRB153G	PRB153Q
	B154 Process Blue	PRB154G	PRB154Q
	B155 Reflex Blue	PRB155G	PRB155Q
	B156 Brilliant Blue	PRB156G	PRB156Q
	B158 Dark Blue	PRB158G	PRB158Q
	B162 Purple	PRB162G	PRB162Q
	B164 Process Purple	PRB164G	PRB164Q
	B165 Rubine Red	PRB165G	PRB165Q
	B166 Magenta	PRB166G	PRB166Q
	B180 Light Gray	PRB180G	PRB180Q

Aquacote Water-Based Bulletin Enamel



Aquacote is a waterborne, low odor, high gloss, solid covering, acrylic Bulletin Enamel formulated for graphic arts and maintenance applications. It is lead free, fast drying, easy brushing, environmentally friendly, VOC compliant and easy clean up. It produces a durable, flexible, weather resistant finish and exhibits excellent adhesion to wood, steel, concrete, galvanized metal, aluminum and treated or untreated vinyl. It is recommended for painting backgrounds, lettering copy and graphics on signs, outdoor advertising billboards, metal highway signs, commercial signs and vinyl banners.

		GALLON	QUART	PINT
	DESCRIPTION	ITEM NO.	ITEM NO.	ITEM NO.
	WB021 Black	PRWB21G	PRWB21Q	PRWB21P
	WB101 White	PRWB101G	PRB101Q	PRB101P
	WB102 Fire Red	PRWB102G	PRWB102Q	PRWB102P
	WB104 Bright Red	PRWB104G	PRWB104Q	PRWB104P
	WB107 Imitation Gold	PRWB107G	PRWB107Q	PRWB107P
	WB108 Maroon	PRWB108G	PRWB108Q	PRWB108P
	WB114 Medium Brown	PRWB114G	PRWB114Q	PRWB114P
	WB116 Ivory	PRWB116G	PRWB116Q	PRWB116P
	WB124 Medium Orange	PRWB124G	PRWB124Q	PRWB124P
	WB130 Primrose Yellow	PRWB130G	PRWB130Q	PRWB130P
	WB132 Lemon Yellow	PRWB132G	PRWB132Q	PRWB132P
	WB142 Emerald Green	PRWB142G	PRWB142Q	PRWB142P
	WB143 Process Green	PRWB143G	PRWB143Q	PRWB143P
	WB148 Dark Green	PRWB148G	PRWB148Q	PRWB148P
	WB152 Light Blue	PRWB152G	PRWB152Q	PRWB152P
	WB154 Process Blue	PRWB154G	PRWB154Q	PRWB154P
	WB155 Reflex Blue	PRWB155G	PRWB155Q	PRWB155P
	WB156 Brilliant Blue	PRWB156G	PRWB156Q	PRWB156P
	WB162 Purple	PRWB162G	PRWB162Q	PRWB162P
	WB164 Process Purple	PRWB164G	PRWB164Q	PRWB164P
	WB166 Magenta	PRWB166G	PRWB166Q	PRWB166P
	WB2202 White White	PRWB2202G	PRWB2202Q	PRWB2202P
	WBCL Clear Base - Gloss	PRWBCLG	PRWBCLQ	PRWBCLP
	WBFL Flattening Clear	PRWBFLG	PRWBFLQ	PRWBFLP



Fast Dry Gold Size

An exceptional, self-leveling and fast setting size for use in gold leafing. Designed to retain elasticity. The Fast Dry Gold Size allows gilding to begin in about an hour, and engine turning for up to an additional 8 hours after application.



ITEM NO. P4008PT

Luco Gold Size

Available in quick and slow set. The Quick Set Gold Size is a clear gilder's varnish designed for fast leaf work. It may also be used as a clear protective top coat over leaf, lettering and other decorative work. The Slow Set Gold Size is a Gilder's Oil designed for all leaf work where extended tack time is allowed, greater brilliance is desired and a clear protective top coat is not necessary.



ITEM NO.	DESCRIPTION	SIZE
GSQP	Quick-Dry Gold Size	Pint
GSSP	Slow-Dry Gold Size	Pint

Liquid Gold

A solvent-based solid covering, quick drying, non-smudge, metallic acrylic coating that dries to a smooth, durable, weather and tarnish resistant finish. It is formulated for use as an interior and exterior finish on wood, metal, and glass. 1 Quart.



ITEM NO. PRLGQ

Bulletin

Aqua Leaf, Water Based Metallic Look Finish

Aqua Leaf is a water based, lead free, non-gassing, pearlescent, metallic-like coating with built in ultra violet protection. It is formulated with nacreous pigments to yield a lustrous metallic look. It dries to a flexible, weather & fade resistant, bright metallic like finish and exhibits excellent adhesion to wood, metal, treated and untreated vinyl and many other substrates.



		GALLON	QUART
	DESCRIPTION	ITEM NO.	ITEM NO.
	WP01 Silver	PRWP01G	PRWP01Q
	WP02 Brass	PRWP02G	PRWP02Q
	WP03 Inca Gold	PRWP03G	PRWP03Q
	WP04 Mayan Gold	PRWP04G	PRWP04Q
	WP05 Copper	PRWP05G	PRWP05Q
	WP06 Bronze	PRWP06G	PRWP06Q
	WP07 Aztec Gold	PRWP07G	PRWP07Q
	WP08 Duranodic Bronze	PRWP08G	PRWP08Q
	WP09 Rich Gold	PRWP09G	PRWP09Q
	WP10 Metallic Blue	PRWP10G	PRWP10Q
	WP11 Metallic Violet	PRWP11G	PRWP11Q
	WP12 Emerald Green	PRWP12G	PRWP12Q
	WP13 Patina	PRWP13G	PRWP13Q
	WP14 Pearl	PRWP14G	PRWP14Q
	WP15 Oyster White	PRWP15G	PRWP15Q
	WP16 Gun Metal	PRWP16G	PRWP16Q
	WP17 White (Tint Base)	PRWP17G	PRWP17Q
	WP18 Real Gold	PRWP18G	PRWP18Q
	WP19 Platinum	PRWP19G	PRWP19Q
	WP20 Statuary	PRWP20G	PRWP20Q
	WP21 Teal	PRWP21G	PRWP21Q
	WP22 Penny Copper	PRWP22G	PRWP22Q
	WF01 Interference Silver/Gold	PRWF01G	PRWF01Q
	WPFC Aqua Leaf Flow Control	PRWPFCG	PRWPFCQ



Learn more about our many fine products at our website
www.sfsupplies.com

In addition to item description and specs you can view large detailed images of all the items



MasterCatalog.pdf

A PDF version of our Master Catalog is available on our site for you to download

Primers & Clear Coatings

Solvent-Based Primers

Fast Dry Blockout White



A fast drying, high opacity, solvent reducible alkyd primer designed to "block out" previously painted sign faces. It is also an excellent primer for wood and MDO board.

ITEM NO.	SIZE
PRBFDB05G	5 Gallon
PRBFDBOG	1 Gallon
PRBFDBOQ	Quart

Sticktite White Metal & Wood Primer



A fast drying, high opacity, solvent reducible alkyd primer designed for use on metal, wood and MDO board. May also be used as a primer for properly prepared galvanized metal. Dries with a low luster finish.

ITEM NO.	SIZE
PRBSTWPG	1 Gallon
PRBSTWPQ	Quart

Masonite Primer



A solvent reducible, alkyd primer designed for use on tempered masonite. It provides excellent adhesion and retains the smooth appearance of the masonite sheet.

ITEM NO.	SIZE
PRBMPG	1 Gallon

Zinc Primer (Chromate Free) Metal Primer



A yellow alkyd/linseed oil composition corrosion resistant primer that utilizes new pigment technology to replace the outdated chromate composition. This coating system exhibits excellent corrosion resistance on properly prepared metal surfaces.

ITEM NO.	SIZE
PRBZCPG	1 Gallon

Universal Metal Primer



A fast drying, high performance, rust inhibitive, phenolated alkyd primer that exhibits excellent adhesion and penetration. May be top-coated with virtually any paint system, including Bulletin Color, Background Enamel, lacquers, acrylic enamels, synthetic enamels as well as two component urethanes and epoxies. Recommended for use as a primer over a variety of aluminum, steel, galvanized metal, wood and concrete surfaces.

ITEM NO.	COLOR
PRUPGG	Gray
PRUPROG	Red Oxide
PRUPWG	White

Water-Based Primers

Prime-All



A unique, interior-exterior, waterborne, acrylic primer that combines fast dry convenience with outstanding adhesion, sealing, stain blocking, corrosion resisting and weathering properties. Excellent adhesion to aged steel, wood, aged galvanized metal, weathered aluminum, MDO plywood, conventional plywood, cement, Fiberglas, concrete, plastic, ceramic, flexible vinyl and glass substrates.

ITEM NO.	SIZE
PRPRALW5G	5 Gallon
PRPRALWG	1 Gallon

Prime Lock DTM (Direct to Metal) Primer



A unique, corrosion resistant, waterborne, 100% acrylic primer formulated for use on difficult to adhere to metal & plastic surfaces. Excellent adhesion to steel, galvanized metal, aluminum, zinc aluminum, baked aluminum, tin, rigid PVC and other plastic surfaces. Available in White and Gray.

ITEM NO.	SIZE
PRPLDTMWG	1 Gallon

Clear Coatings Solvent Based

Acrylic Clear Overcoat



A solvent based, fast drying, acrylic clear topcoat specially formulated to provide long lasting protection to painted surfaces. Designed for use as a topcoat on painted signs and bulletins, oil color signs, gold leaf lettering or wherever resistance to the effects of long-term exposure to weather is a requirement.

ITEM NO.	SIZE
PRBACOQ	1 Quart
PRBACOG	1 Gallon

Sign Finishing Clear

An excellent medium for creating glazes using Bulletin Colors, Lettering Enamels and Japan Colors. Not recommended for top coating signs.



ITEM NO.	SIZE
PRBSFCQ	1 Quart
PRBSFCG	1 Gallon

4005 Speed Dry UV Acrylic Clear



Fast drying and crystal clear. A multipurpose solvent based acrylic clear that provides excellent UV protection. Ideal as a protective topcoat on thermal and solvent based prints.



ITEM NO.	SIZE
P4005Q	1 Quart
P4005G	1 Gallon
P4005A	12 oz. Aerosol

Sign Restoring Clear (4003)



Often an alternative to completely repainting a sign with Lettering Enamels or Bulletin Colors, this oil-based clear finish may be used to partially restore gloss levels.

ITEM NO.	SIZE
P4003Q	1 Quart

Paints, Additives & Reducers

Glowz Glow-In-The-Dark



This glow in the dark paint really makes your projects stand out! It's highly visible at night, making it perfect for items from camping equipment to your car keys. Best if used over white base.



- High night visibility
- Produces glowing effect
- Recharges with exposure to light

ITEM NO.	SIZE
KR5220	8 oz.

Rich Art Window Paint

Rich Art Window Paint is water resistant, yet it can easily be removed from windows with warm soapy water and ammonia. This specially formulated paint adheres to almost any glass surface, including most tinted and coated windows.



ITEM NO.	COLOR	SIZE
PW-14G	W-14 White	Gallon
PW-14P	W-14 White	Pint
PW-24P	W-24 Black	Pint
PW-30P	W-30 Lemon Yellow	Pint
PW-31P	W-31 Yellow	Pint
PW-42P	W-42 Orange	Pint
PW-50P	W-50 Blazing Red	Pint
PW-52P	W-52 Red	Pint
PW-61P	W-61 Turquoise	Pint
PW-62P	W-62 Deep Blue	Pint
PW-72P	W-72 Green	Pint
PW-77P	W-77 Deep Green	Pint
PW-81P	W-81 Magenta	Pint
PW-83P	W-83 Purple	Pint
PW-92P	W-92 Burnt Sienna	Pint
PW-93P	W-93 Burnt Umber	Pint

T-4 SIGN BEADS



ITEM NO.	SIZE
PT4SB	1 lb.

Hardener 4007



Designed to accelerate drying time for alkyd based paints including: Lettering Enamels, Bulletin Colors, Gloss Enamels, and Pearlescent Enamels. Will improve adhesion to most substrates as well as extend color life and increase gloss. Also, will aid in preventing lifting when an automotive clear coat is to be applied over the paint.



ITEM NO.	SIZE
P4007P	1 Pint

Reducer 6000, 6001, 6002



Reducer 6000, Low Temp Reducer 6001 & High Temp Reducer 6002 are designed to reduce viscosity under specialized conditions and adjust flow without altering the quality of the coating being reduced.



ITEM NO.	DESCRIPTION	SIZE
P6000Q	Reducer 6000	1 Quart
P6001Q	Reducer 6001	1 Quart
P6002Q	Reducer 6002	1 Quart

Brush Conditioner and Cleaner 4004



A premium product designed for conditioning, cleaning and storing brushes. Excellent for reconditioning, softening and renewing hardened natural and nylon brushes, without interfering with the proper ties of oil-based sign paints. Available in quarts.



ITEM NO.	SIZE
P4004Q	1 Quart

Super Gloss Tinting Clear 4006



Designed primarily for achieving various halftones and shades of color. Excellent for the creation of tones from fully transparent to fully opaque colors.



ITEM NO.	SIZE
P4006P	1 Pint
P4006Q	1 Quart

Tinting Black 4001



Mix with lettering White or Bulletin White; may also be used to darken and deepen "1 SHOT" Lettering Enamels and Bulletin Colors.



ITEM NO.	SIZE
P4001P	1 Pint

Tinting White 4002



Oil based white for use in tinting Lettering Enamels and Bulletin Colors without affecting the properties of the base coatings.



ITEM NO.	SIZE
P4002P	1 Pint

Wall Dog Brush Oil

The ideal acid-free product to protect and condition your sign, lettering, pinstriping and fine art brushes!



- Prevent paint build up in the hair and heel of brushes.
- Maintains the shape at the brushes and keeps it soft.
- Restores the natural oil to the hair of the brushes.

ITEM NO.	SIZE
TSWDBOP	1 Pint

Bestine Solvent and Thinner

Bestine solvent and thinner formulated for thinning rubber cement, Bestine is also a most versatile cleaner. Bestine readily cleans up inks, spray adhesive, and is an exceptional parts cleaner.



ITEM NO.	SIZE
TSBG	Gallon
TSB55G	55 Gallon Drum

WIL-Bond

WIL-Bond is a liquid preparation that cuts gloss on painted or varnished surfaces so new finish goes on smoothly, bonds tightly and lasts longer. May be used with latex, oil-base or any other paint or enamel for better adhesion.



ITEM NO.	SIZE
TSWBQ	Quart
TSWBG	Gallon

Paint Thinner

Paint Thinner meets the demanding requirements of the environmentally conscious consumer. The toxicity potential is very low, and its characteristics make it an excellent choice for indoor use. It can be used for most application where mineral spirits or paint thinner is recommended.



ITEM NO.	SIZE
TSPTG	Gallon

Goof Off Graffiti Remover

The quick, easy and proven way to remove graffiti. Specially formulated to cut through spray paint, ink, — powerfully dissolving graffiti without damaging the surface below. Use it on stone, brick, wood, metal, glass, block — and even some factory baked auto finishes.



ITEM NO.	SIZE
TSGRGO	16 oz. spray

Mineral spirits

Mineral spirits is the most commonly recommended general purpose solvent available. It is often specified on oil based paint, varnish and other solvent thinned product labels Mineral Spirits is also useful for removing oil, tar and wax from most surfaces safely.



ITEM NO.	SIZE
TSMS	Gallon

Naphtha

Naphtha evaporates approximately five times faster than mineral spirits type paint thinners, which speeds the drying time of oil-based paints, enamels and varnishes. Naphtha also degreases and cleans metal, porcelain, wood surfaces. It also thins some adhesives and rubber cements.



ITEM NO.	SIZE
TSNAG	Gallon

Gum Turpentine

The original paint solvent, refined from the living pine tree. Its gum resin has a natural affinity for wood, and allows turpentine to carry the pigment-binding resin of paints deeply into the wood, resulting in the strongest possible bond. Use to safely clean and preserve natural bristle brushes.



ITEM NO.	SIZE
TSGTG	Gallon

Steam Distilled Turpentine

Steam Distilled Turpentine is derived from stumps and remnants of lumbering operations. It has the same solvent power as Gum Turpentine, but without the natural gum resin content. It has a mild characteristic pine odor, high solvent power and medium drying speed.



ITEM NO.	SIZE
TSTPG	Gallon

Denatured Alcohol Solvent

The highest quality denatures ethyl alcohol. Use it as a shellac thinner and a clean burning fuel; specifically for use with alcohol burning appliances. Available in 5 gallon, 1 Gallon, Quart and pint metal containers.



ITEM NO.	SIZE
TSALG	Gallon

Acetone

An extremely powerful, fast evaporating chemical having a variety of uses. It is often specified as a thinning solvent for lacquers, epoxies, vinyl and various mastic's. It is also commonly used with fiberglass and other polyester resins used in boat and auto body repairs. Being 100% water miscible, Acetone may be cut with water to reduce its bite when cleaning fiberglass or other appropriate surfaces.



ITEM NO.	SIZE
TSASG	Gallon

Lacquer Thinner

This general purpose thinner is a medium evaporator and may be used as a reducer for both nitrocellulose and epoxy lacquers. A good choice for brushing, dipping and spraying lacquers. Medium – Fast Drying.



ITEM NO.	SIZE
TSLQG	Gallon

Metal Sign Paint



Metal Sign Paint

MARK 1 is an advanced metal sign paint process that uses a universal colorant system to provide both a compliant 2.8 VOC formulation and a conventional 4.0 VOC formulation in a single coating system. Available in a full range of glosses and an extended range of intermix colors through Spraylat's new Integrated Color Matching System. This coating system is also fast dry, smooth and very easy to apply in production. The weatherability of Spraylat's MARK I coatings is excellent when applied over Spraylat's recommended wash primer or epoxy primer

- Fast Dry, Acrylic Urethane Chemistry
- Versatile, Multi-Formulation 2K System
- -2.8 VOC Complaint Product
- -4.0 VOC Conventional Product
- Extensive Range of Colors
- Available in Satin and Gloss Finishes
- Excellent Weatherability, Durability, Cleanability
- Very Smooth Finish
- Easy Application in Production



Satin

ITEM NO.	COLOR
PSM102S	White
PSM111S	Violet
PSM112S	Maroon
PSM113S	Magenta
PSM114S	Cherry Red
PSM115S	Red Oxide
PSM117S	Yellow Oxide
PSM120S	Regal Blue
PSM121S	Pthalo Green
PSM122S	Brunt Umber
PSM123S	Black
PSM125S	Liberty Blue
PSM130S	Cardinal Red
PSM140S	Sunflower Yellow
PSM142S	Lemon Yellow
PSM147S	Poppy Red
PSM177S	Clear Gallon
PSM131S	Transparent Red Oxide
PSM132S	Transparent Yellow
PSM151S	Medium Aluminum
PSM152S	Fine Aluminum
PSM153S	Coarse Aluminum
PSM154S	Extra Fine Aluminum

Gloss

ITEM NO.	COLOR
PSM302G	White
PSM311G	Violet
PSM312G	Maroon
PSM313G	Magenta
PSM314G	Cherry Red
PSM315G	Red Oxide
PSM317G	Yellow Oxide
PSM320G	Regal Blue
PSM321G	Pthalo Green
PSM322G	Brunt Umber
PSM323G	Black
PSM325G	Liberty Blue
PSM330G	Cardinal Red
PSM340G	Sunflower Yellow
PSM342G	Lemon Yellow
PSM347G	Poppy Red
PSM377G	Clear Gallon
PSM331G	Transparent Red Oxide
PSM332G	Transparent Yellow

These intermix colors can be mixed to match thousands of colors.
S&F will mix your custom color.



Catalyst

ITEM NO.	DESCRIPTION
PSM380V	Gloss Modifier VOC
PSM381C	Gloss Modifier Conventional
PSM150V	Catalyst 2.8 VOC
PSM156V	Catalyst 3.5 VOC
PSM151C	Catalyst Conventional
PSM181C	Catalyst High Gloss
PSM390C	Gloss Enhancer

Reducers

ITEM NO.	DESCRIPTION
PSM165C	Reducer Conventional
PSM168V	Reducer E 3.5 VOC
PSM169V	Reducer E 2.8 VOC
PSM197C	Reducer Conventional Warm Temp.
PSM198V	Reducer 3.5 VOC Warm Temp.
PSM199V	Reducer 3.5 VOC Hot Temp.

ITEM NO.	DESCRIPTION
PSMBR500	Brush & Roll Additive
PSM190V	Universal Retarder Qt.
PSM164A	Accelerator Qt.
PSM166A	Tape IT Accelerator Qt.
PSMMC-509	Metal Cleaner

Mix ratio for Mark 1

FOR A NON-COMPLIANT SYSTEM:

Three (3) parts Mark 1 Color to one (1) part Catalyst SM151C to one (1) part Reducer SM165C

FOR A 2.8 VOC COMPLIANT SYSTEM:

Three (3) parts Mark 1 Color to one (1) part Catalyst SM150V to one (1) part Reducer SM161V

FOR A 3.5 VOC COMPLIANT SYSTEM:

Three (3) parts Mark 1 Color to one (1) part Catalyst SM150V to one (1) part Reducer SM195V

Brushes & Rollers



Field Master

1 Shot's Field Master coatings are high quality, yet affordable, easy to use, single stage, isocyanate-free coatings, color matched precisely to your program specifications. Field Master is a 2.8 VOC system that is field ready for brush, roller, or spray applications.

1 Shot's Field Master products may be used for a wide range of exterior or interior applications. Whether you are painting at local, regional, or national locations, Field Master, available in large or small quantities, is batch made and custom matched to program specifications.

The advantages of 1 Shot's Field Master products include:

- Repeatable batch made color
- Supplied as an easy to use single stage product
- 20,000 Standard Colors readily available through our intermix program
- Custom Colors or Corporate Specials
- No pot life issues

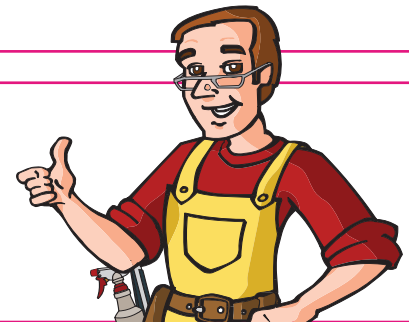

Custom Colors?

We offer paint mixing for the Spraylat MarkI and Field Master intermix paints. They can be mixed to match an extensive range of colors. Please call us to discuss your custom color needs.

Roller & Tray

9" Pink Mohair Roller Lint-free

- 9"x1/4" – Mohair
- Deluxe fabric and long life core
- For all paints and coatings
- 100% guaranteed



ITEM NO. TSMHR

9" White Roller

- 9"x1/4" – White
- Extra thick phenolic core
- Designed to withstand all types of solvents
- Lint-free guarantee



ITEM NO. TSRR

9" Black Foam Roller

ITEM NO. TSFR9



9" Roller Handle

ITEM NO. TSRH



3" Roller Handle

ITEM NO. TSRH3



3" Black Foam Roller

ITEM NO. TSFR3



9" Metal Paint Tray

ITEM NO. TSMT



3" Trim and Touch-Up Roller

- Handy tray included
- For small painting projects and blending in touch-ups
- Small diameter roller fits in tight places



ITEM NO. TS3RK

3" Trim and Touch-Up Roller Refill

2 per pack

ITEM NO. TS3RR



9" Paint Tray Plastic Inserts

ITEM NO. TSMTPI

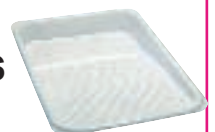

See brushes on page 166

Paint Supplies

Tape

Masking Tape

A general purpose, semi-bleached, crepe paper with excellent tensile strength. Very comfortable; good resistance to "bleed-through". Natural rubber adhesive. Used for a variety of home and industrial applications.



ITEM NO.	DESCRIPTION
LYMT3/4	3/4"
LYMT1	1"
LYMT1-1/2	1-1/2"
LYMT2	2"
LYMT3	3"

Scotch-Blue™ Painters Masking Tape #2090

This tape removes cleanly without adhesive transfer or surface damage for up to 14 days, even in direct sunlight.



ITEM NO.	DESCRIPTION
LY3M20901	1" x 60 yds.
LY3M209034	3/4" x 60 yds.

Lettering Tape

3/8"x180 yards
Available in Clear or Red.



ITEM NO.	DESCRIPTION
LYT38CL	Clear, 3/8"x180yds
LYT38R	Red, 3/8"x180yds

Fabtac Adhesive Stencil



ITEM NO.	SIZE
AWAS1820	18" x 20yd.
AWAS1830	18" x 30yd.
AWAS2410	24" x 10yd.
AWAS2430	24" x 30yd.

Paint Mask



ITEM NO.	SIZE	COLOR
VA1828-S-C	15" x 150'	White
VA1830-S-C	15" x 150'	Yellow
VA1828-S-J	20" x 150'	White
VA1830-S-J	20" x 150'	Yellow
VA1828-S-M	24" x 150'	White
VA1828-S-Q	30" x 150'	White
VA1830-S-Q	30" x 150'	Yellow
VA1828-S-U	48" x 150'	White
VA1828-S-W	60" x 150'	White
VA1830-S-W	60" x 150'	Yellow

Dust Mask



ITEM NO.	DESCRIPTION
HDDM50	50 pack
HDDM	5 pack

Gloves



ITEM NO.	DESCRIPTION
HDGD	Dotted Gloves
HDGR	Red Gloves

Gold Leaf

25 Pages per book.
20 Books per box.

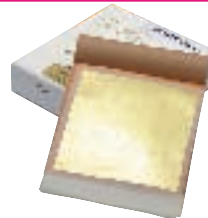

ITEM NO.	DESCRIPTION
GL23XXD	Book 23k Deep XX Gold Leaf (Germany) Special Order
GL23P	Book 23k Patent Gold Leaf (Australian)
GLSL	Book Loose Silver Leaf (Germany)
GLSLP	Book Patent Silver Leaf (Germany)

Pantone Color Formula Guide

PANTONE



INCLUDES:

- Pantone Formula Guide Solid Coated
- Pantone Formula Guide Solid Uncoated

ITEM NO.	DESCRIPTION
PCFG	Printer Edition

Questions?

Need help selecting the best product? Our "signology" experts will be happy to provide you with clear, concise answers – just ask!



ProGrade™ Yellow Paint Mask



A yellow paint mask with a removable adhesive, can be computer plotted or sandblasted. Designed to the highest industry standards -- "professional grade".



ITEM NO.	SIZE
VPGPMY30150	30" x 150'
VPGPMY48150	48" x 150'
VPGPMY60150	60" x 150'
VPG48250	48" x 750'
VPG60250	60" x 750'

Spray Paint

Interior-Exterior Spray Paint for General Purpose

No Runs, No Drips, No Errors!™ This fast-drying paint creates a smooth professional finish every time. And it dries in 12 minutes or less, which means you can get the look you want in no time!

- Smooth, long lasting finish
- Excellent weather resistance
- Available in 52 colors



ITEM NO.	COLOR
KR1501	Glossy White
KR1502	Flat White
KR1508	Semi-Gloss White
KR1506	Almond
KR2108	Banner Red
KR2101	Cherry Red
KR1910	True Blue
KR1901	Regal Blue
KR1908	Chevy Blue
KR1913	Purple
KR1806	Sun Yellow
KR2016	Emerald Green
KR2001	Hunter Green
KR2501	Leather Brown
KR1606	Pewter Gray
KR1608	Smoke Gray
KR1613	Semi-Flat Black
KR1602	Ultra-Flat Black
KR1601	Glossy Black
KR1301	Crystal Clear Acrylic Gloss
KR1313	Crystal Clear Acrylic Satin

Fusion for Plastic

This top-selling paint is the first of its kind that bonds directly to most plastics. Turn a treasured toy into something new again. Get many more years of enjoyment out of your outdoor patio furniture.

- No sanding, no priming, no fuss
- Features the EZ Touch Fan™ Spray Nozzle



ITEM NO.	COLOR
KR2320	#2320 Glossy White
KR2321	#2321 Glossy Black
KR2420	#2420 Satin White
KR2421	#2421 Satin Black

Interior-Exterior Primer

Start here to get the most out of your paint project. Priming your surface is easy to do and helps you achieve better results.

- Increases paint adhesion
- Smooths uneven surfaces
- Ensures true paint color is achieved



ITEM NO.	DESCRIPTION
KR1318	All-Purpose Gray Primer
KR1315	All-Purpose White Primer

Fluorescent Spray Paints

Get bold with Krylon® Fluorescent Paints. Neon colors provide high visibility for greater safety in your home, office or shop.

- For safety and decor items
- Glows under ultraviolet (black) light.



ITEM NO.	COLOR
KR3109	Blue
KR3105	Cerise
KR3106	Green
KR3104	Lemon Yellow
KR3101	Red-Orange
KR3102	Yellow-Orange

OSHA Color Paints

Use Krylon® OSHA Color Paints to make any surface safe and provide protection from adverse weather conditions, moisture, and industrial fumes. OSHA colors can be sprayed on metal, plastic, wood, and masonry.

- APWA color standards
- High visibility safety colors
- Mark physical hazards, designate caution



ITEM NO.	COLOR
KR2012	Safety Green
KR2410	Safety Orange
KR1929	Safety Purple
KR2116	Safety Red
KR1813	Safety Yellow

Matte Finish

Protect and enhance your finished project with this permanent, non-glossy finish. It reduces sheen and light reflection, while providing invisible protection.

ITEM NO. KR1311



UV-Resistant Clear Coating

For a permanent, protective coating start here. This tough finish does not yellow with age and protects arts, crafts and valuables.

ITEM NO. KR1305



Workable Fixatif

Delivers a workable finish and lasting protection for artwork.

- Eliminates smudging, wrinkling and gloss
- Protects pencil, charcoals, pastels, chalk, tempura, conte, crayon, watercolor, India ink and more

ITEM NO. KR1306



Metallic Paints

Create metallic accents that dry quickly to a brilliant shine with Metallic Spray Paint.

- Dries quickly
- Easy to use
- Brilliant metallic-like finish



ITEM NO.	COLOR
KR1401	Bright Silver
KR1403	Dull Aluminum
KR1404	Chrome Aluminum
KR1406	Silver Metallic
KR1701	Bright Gold
KR1706	#1706 Gold Metallic
KR1709	Copper Metallic
KR2203	#2203 Copper Metallic
KR2204	#2204 Brass Metallic
KR2205	Light Anodized Bronze
KR2206	Dark Anodized Bronze

Spray Paint

Tough Coat



Industrial Tough Coat Acrylic Enamel provides the ultimate in durability and protective finishes. All colors contain a high amount of solids to assure maximum coverage on metal and wood.



ITEM NO. COLOR

KR1760	#1760 Aluminum
KR1800	#1800 OSHA White
KR3720	#3720 Flat White

Metal Trim and Anodizing Paint



A fast drying specialty pigmented coating used for the touch-up and installation of anodized and painted building components. Excellent outdoor color retention.

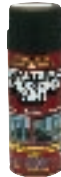

For use in window and door frames, railings, gutters, and other metal trim. Also excellent for the touch-up and installation of storefronts, fascia, and curtain walls.

ITEM NO. DESCRIPTION

KRBZ	Bronze #1857
------	--------------

Farm & Implement Paints



Give your farm, lawn and garden equipment a fresh, new look that stands up to the harshest weather and chemicals.



- Original equipment colors
- High-gloss, factory-like colors
- Weather and chemical resistant

ITEM NO. COLOR

KR1809	School Bus Yellow
KR1818	Amer. Beauty Red

AwnTube™ Matchmaker Touch-Up Paint

Corrosion resistant touch-up paint gives awning a perfect clean look after welding.
12/Case, 12 oz. each



ITEM NO. AWTSP

Sprayon® Zinc-Rich Cold Galvanizing Compound



A high performance primer containing 97% pure zinc dust pigment blended with epoxy resin. The compound fuses zinc to the metal substrate and delivers protection against corrosion equal to or better than hot dipped galvanize.

ITEM NO. KRS00740

Frog Juice Spray



Frog Juice is very glossy. It is a relative to automotive clear. It is totally synthetic and will not yellow. It does not require a hardener or catalyst. Achieves maximum hardness slowly over a period of 30 days, yet is ready to handle and place outdoors in 30 minutes.
12 oz. spray can.



ITEM NO. COLOR

LYSFS7002	#7002 Bug Eye White
LYSFS7003	#7003 Fly Black
LYSFS7005	#7005 Pond Water Blue
LYSFS7006	#7006 Lily Yellow
LYSFS7009	#7009 Sunset Orange
LYSFS7012	#7012 Water Beetle Burgundy
LYSFS7014	#7014 Ladybug Red
LYSFS7017	#7017 Blue Fly Blue
LYSFS7024	#7024 Toad Green
LYSFS7028	#7028 Frog Wart Grey
LYSFS7052	#7052 Tadpole Grey
LYSFS7060	#7060 Squashed Frog Red
LYSFS7061	#7061 Frog Green
LYSFS7067	#7067 Frog Split Yellow
LYSFS7071	#7071 Eel Teal
LYSFS7074	#7074 Pollywog Purple
LYSFS7108	#7108 Buzzard Blue
LYSFS7139	#7139 Cattail Brown
LYSFS7076	#7176 Frog Tongue Pink
LYSFSC	Clear Juice

Brushes

Luco Round Lettering Brushes Series 95 RD

These round lettering brushes are made of Kazan squirrel hair fitted into a seamless round nickel-plated brass ferrule. They feature short, dark blue handles.



ITEM NO. SIZE ITEM NO. SIZE

B95RD0	#0	B95RD11	#11
B95RD1	#1	B95RD12	#12
B95RD2	#2	B95RD14	#14
B95RD3	#3	B95RD16	#16
B95RD4	#4	B95RD18	#18
B95RD5	#5	B95RD20	#20
B95RD6	#6	B95RD22	#22
B95RD8	#8	B95RD24	#24
B95RD9	#9	B95RD26	#26
B95RD10	#10	B95RD28	#28

Kolonok Artist Brush 1607, Flat

Kolonok is a top brand in Kolinsky sable artist brushes. Each Kolonok brush is thoroughly inspect before sending it to you. In addition, each Kolinsky sable brush is tested with water. Only the finest artist brushes are shipped to you.

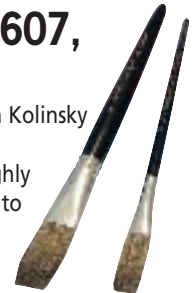

ITEM NO. SIZE ITEM NO. SIZE

B160714	1/4"	B160734	3/4"
B160738	3/8"	B16071	1"
B160712	1/2"		

Artist Brush 1625, Flat



ITEM NO. SIZE ITEM NO. SIZE

B162518	1/8"	B162512	1/2"
B1625316	3/16"	B162558	5/8"
B162514	1/4"	B162534	3/4"
B1625516	5/16"	B16251	1"
B162538	3/8"	B1625114	1 1/4"



www.sfsupplies.com

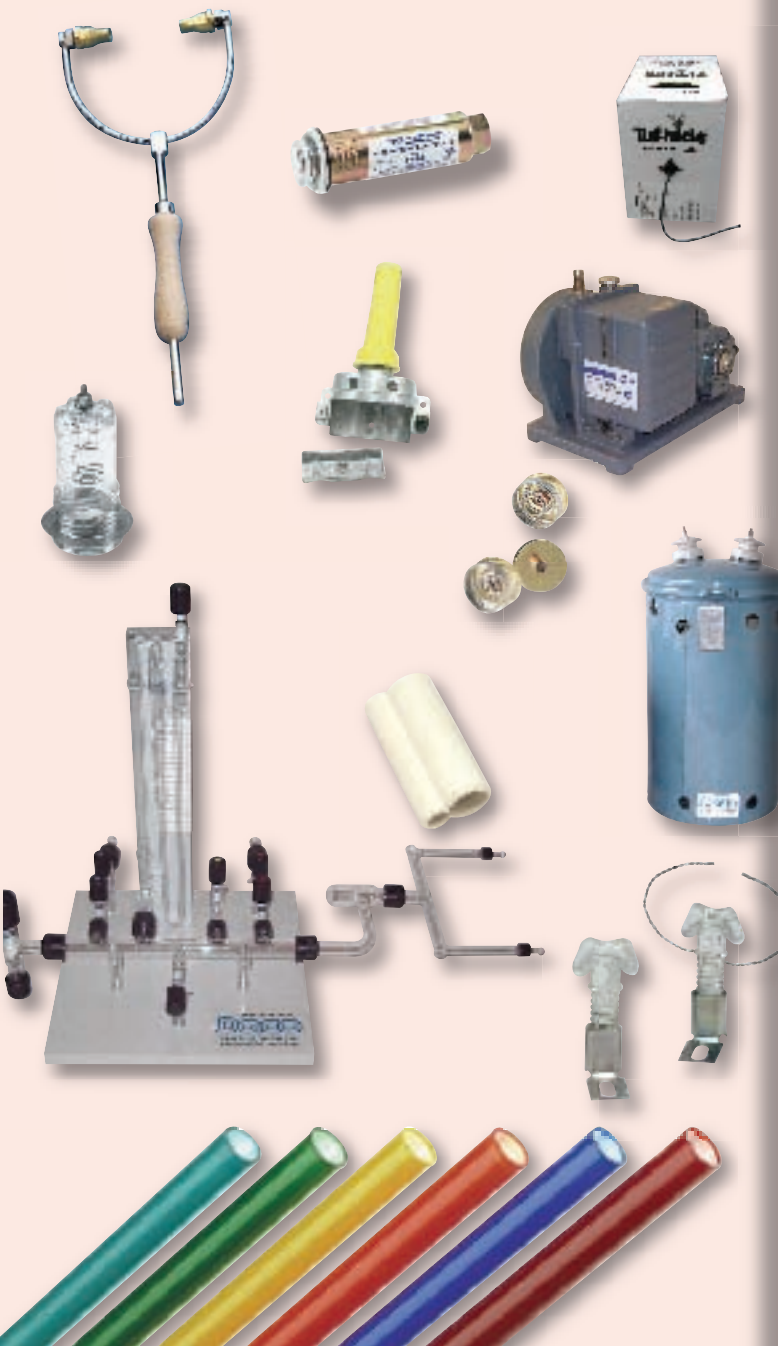

INDEX

DIGITAL MEDIA	5
SIGN VINYL	45
VINYL AND WRAP SUPPLIES	59
WIDE FORMAT EQUIPMENT	73
VINYL CUTTERS	87
ENGRAVERS	95
SOFTWARE	97
SUBSTRATES	105
BANNER	127
SIGN DISPLAY	139
TAPES & ADHESIVES	145
PAINT	153
NEON SUPPLIES & EQUIPMENT	167
GLASS PROCESSING	
Manifolds	169-179
Bombarding.....	180
NEON PROCESSING	
Glass.....	181-182
Glass Bending	183-186
Tools.....	187-188
GLASS TUBING	
EGL Tubing	189-192
Electrodes.....	193
INSTALLATION	
Housing	194-197
Wiring & Connecting.....	198-203
Tube Support	204-205
TRANSFORMERS	207
LED SYSTEMS	229
LIGHTING & ELECTRIC	243
SIGN EXTRUSION	267
LETTER & ACCESSORIES	277
MOUNTING HARDWARE	281
EQUIPMENT & SHOP TOOLS	293

Manifold Systems



Manifold and Complete Pumping System for Neon Tubing

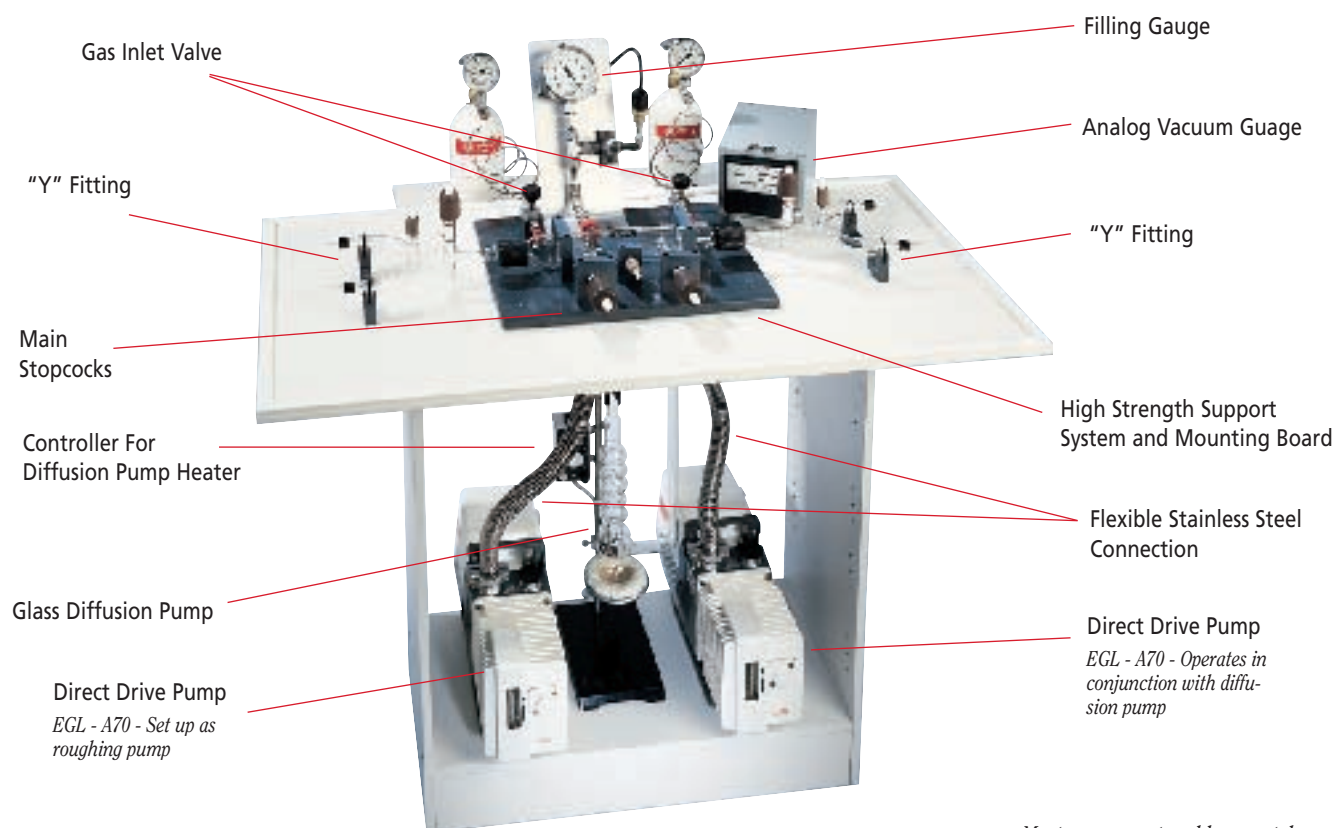

Gas Inlet Valve

"Y" Fitting

Main Stopcocks

Controller For Diffusion Pump Heater

Glass Diffusion Pump

Direct Drive Pump
EGL - A70 - Set up as roughing pump

Filling Gauge

Analog Vacuum Gauge

"Y" Fitting

High Strength Support System and Mounting Board

Flexible Stainless Steel Connection

Direct Drive Pump
EGL - A70 - Operates in conjunction with diffusion pump

*Most components sold separately
Stand not available from EGL*

Superior design and construction provide the fastest, most consistent pumping speeds, and the brightest, cleanest neon tubes attainable

The MAXI-VAC™ manifold virtually eliminates the leakage, breakage, contamination, and downtime common to older systems by eliminating the components that cause it. Gone forever are the grease-type stopcocks, numerous connections, and maze of fragile glass tubing which result in wasted repair time and, worse still, finished neon products of inconsistent quality.

Large Bore, Grease-Free Stopcocks

The MAXI-VAC manifold employs the fewest number of stopcocks to minimize the possibility of leakage.

The two 25mm diameter main stopcocks are larger than on any other pumping manifold, providing the highest pumping rates. The stopcocks are machined from durable Teflon®, and feature a new coarse thread design that provides long life, fast actuation, and easy removal and re-threading for cleaning. The stopcocks are also grease-free, eliminating the contamination problem of grease-type stopcocks 100 percent.

Heavy Wall, Large Diameter Manifold Tubing

Short lengths of heavy wall 50mm diameter borosilicate tubing are welded in a compact configuration which has the fewest possible number of connections, then annealed to remove strain. The result is an extremely strong assembly that provides the highest possible flow rates, maximum vacuum integrity, minimal gas waste, and the easiest interior access for cleaning.

Manifolds

Manifold Systems

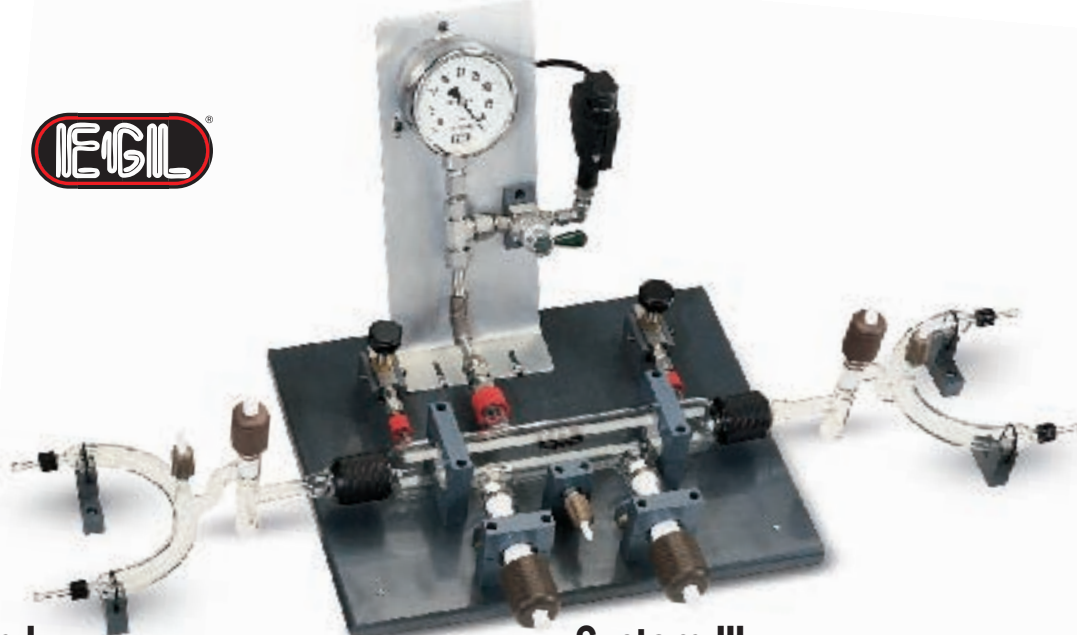

System I

Includes:

- Borosilicate Glass Manifold complete with sturdy base
- 0-40MM HG/TORR fill gauge
- Highly accurate vacuum gauge complete with gauge adapter/stopcock
- Newly designed oil diffusion pump (for maximum pumping performance) complete with heater and ALL necessary mounting hardware

ITEM NO.	DESCRIPTION	
716000	Complete system for gas flasks	120V, 60Hz
716005	Complete system for gas flasks	220V, 50Hz
716010	Complete system for gas tanks*	120V, 60Hz
716015	Complete system for gas tanks*	220V, 50Hz

System II

Includes:

Same as System I. Also includes Series A70 or equivalent vacuum pump with stainless steel flex hose and adapter.

ITEM NO.	DESCRIPTION	
716025	Complete system for gas flasks	120V, 60Hz
716026	Complete system for gas flasks	220V, 50Hz
716027	Complete system for gas tanks*	120V, 60Hz
716028	Complete system for gas tanks*	220V, 50Hz

* Gas Transfer System included with "System IV" only
120V refers to all electrical components except bombarders and chokes (both are 220V primary)

System III

Includes:

Same as System II. Also includes choice of KVA bombarder & variable output transformer choke & milliamp gauge.

ITEM NO.	DESCRIPTION	
716060	Complete system for gas flasks with 15 KVA bombarder and choke	120V, 60Hz
716061	Complete system for gas flasks with 15 KVA bombarder and choke	220V, 50Hz
716062A	Complete system for gas tanks* with 15 KVA bombarder and choke	120V, 60Hz
716063A	Complete system for gas tanks* with 15 KVA bombarder and choke	220V, 50Hz
716078	Complete system for gas flasks with 22 KVA bombarder and choke	120V, 60Hz
716080A	Complete system for gas tanks* with 22 KVA bombarder and choke	120V, 60Hz

System IV

for gas tanks only

Includes:

Same as System III, plus second Series A70 or equivalent vacuum pump with stainless steel flexible hose and adapter, two gas tank systems, EGL digital temperature gauge, set of replacement "O" rings, additional 50cc bottle of clear diffusion pump oil, and 100 pairs of 8cc PREMIUM PLUS electrodes.

ITEM NO.	DESCRIPTION	
716164	Complete system for gas tanks* w/2 Series A70 vacuum pump and 22 KVA bombarder and choke	120V, 60Hz

Manifold Systems

Analog Capsule Fill Pressure Gauge



The EGL Analog Capsule Fill Pressure/Torr Gauge features a four-inch easy-to-read face for precise indication of mm Hg/Torr from 0 to 40 in 1-unit graduations. It has a 1/4" M NPT connection and can be fitted to virtually any manifold using the 19mm glass compression adapter.

Adapter must be used when attaching to a glass manifold.

ITEM NO.	DESCRIPTION
733205	Fill Gauge Complete, includes adapter and support legs
733202	Fill Gauge with Adapter
733200	Fill Gauge Only

EZ Read Gas Pressure Gauge (Manometer)



The EGL EZ Read gauge provides accurate readings of rare gases during neon tube or cold cathode filling. Accuracy of .1mm is possible.

The EGL EZ Read gauge uses a greaseless stopcock assembly designed to prevent the butyl oil from ascending into the manifold system should sudden pressure be applied to the liquid during operation.

Connection is made with a glass compression fitting that will accommodate 12 to 15mm tubing. Each gauge is supplied with a calibrated scale and required gauge oil.

EZ Read Gauge Complete - with stand

ITEM NO. 733600

EZ Read Gauge Glass Only

ITEM NO. 733625

RED Butyl Phthalate Oil, 2oz

ITEM NO. NRBPO



Digital Pirani Vacuum Gauge

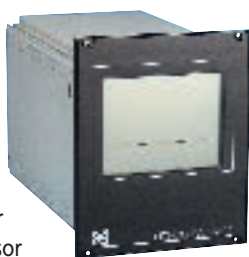

The TM-20 is a single station Pirani Gauge. It can display pressure in Torr, Microns, M-Bar, or Pascal units using a large easy-to-read LCD display with digital and bar graph readout.

Measurement range is from 760 Torr (ATM) down to 1x10 range (1 micron).

Complete gauge includes a TR211 sensor with 1/8" NPT fitting and 10 feet of sensor cable. The gauge can be bench- or panel-mounted and is housed in a 1/4 din case.

ITEM NO. 735370

MAXI-VAC® Single-Stage Borosilicate Oil Diffusion Pump

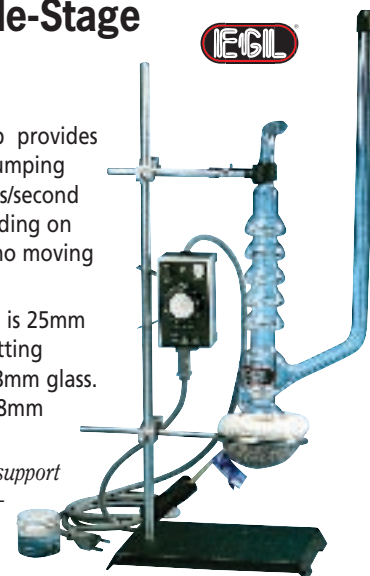

This efficient oil diffusion pump provides pressures of 1×10^{-5} Torr at a pumping rate of approximately 8-10 liters/second (up to 600 liters/minute) depending on backing pump. This pump has no moving parts for easy maintenance.

The Diffusion Pump Intake Port is 25mm diameter with a compression fitting that will accommodate 15 to 18mm glass. The Foreline (Exhaust) port is 18mm diameter.

Complete system includes Vertical support rod with base, pancake heater mantle with support, clamp to secure pump, heater controller, and finest quality diffusion pump oil

ITEM NO.	DESCRIPTION
734300	120V/60 Hz Model
734301	220V/50 Hz model complete
734305	Diffusion pump glass only
734320	Pancake heater mantle, 120V/60Hz
734321	Pancake heater mantle, 220V/50Hz
734315	Heater controller 120V/60Hz
734316	Heater controller 220V/50Hz
713055	Pancake heater support ring
713050	Vertical support rod with base
713060	Diffusion pump clamp
735010	50ml clear diffusion pump oil

Analog Vacuum Gauge



The VT6 Analog Vacuum Gauge is a rugged reliable thermocouple-type instrument. Available in the 0-1000 micron range.

The gauge features a large easy-to-read analog display with 1 micron divisions in the 0-10 micron range. The gauge tubes have a 1/8" male NPT thread. The gauge is supplied with an 8' cable for the gauge tube.

Complete unit includes gauge tube and grounding unit.

ITEM NO.	DESCRIPTION
735340	120/60Hz, Complete unit
735341	220/50Hz, Complete unit
735350	120/60Hz, Gauge only
735351	220/50Hz, Gauge only
735360	Gauge Tube

Manifolds

EGL Gas Transfer System

Maximize quality, consistency, economy with EGL's Gas Transfer System

Simply eliminating system shutdowns for flask replacements will justify investing in this system. In addition, it offers:

- Gas purity: Gas bottled in cylinders maintains its highest purity.
- Tighter control: With the system's pressure gauge, stopcock leakage is virtually non-existent.
- Better economy: Liter-for-liter, costs are reduced by purchasing gas in bulk. EGL tanks are available in 25, 50 and 100 liter sizes.

Additionally, since the tanks are capable of being filled to a much higher pressure than glass flasks, 100% of gas volume will be used rather than approximately 80% when utilizing the glass flasks.

The EGL Gas Transfer System provides uninterrupted flow of pure Neon, Argon or special gas mixtures into tubes for neon signs, cold cathode, etc. A precision-made filling valve eliminates the use of two glass stopcocks. Clean gas flow is guaranteed, as compared to double-stopcock systems which require constant lubrication and can allow air leakage into glass flasks. No entrapped grease vapors are automatically pushed into the neon tubes when the glass stopcocks are used.

No gas losses are incurred when changing glass flasks with small, immeasurable volumes of remaining gases. No labor charges are incurred for each changing of replacement flasks. For example, one fifty (50) liter cylinder will eliminate 50 bottle changes. A system can hold 100% of its gases indefinitely, unlike glass stopcocks which cannot prevent seepage for long periods of time.



EGL Gas Transfer Systems and Components

ITEM NO.	DESCRIPTION
NEGTS	Gas Transfer System (Excluding Tank – One System required per gas tank)
448520	Pressure Gauge
733000	Robbins Valve
733010	Glass fitting for Robbins valve
733020	Metal fitting for Robbins valve
448005	Washer compression set for metal side
448010	Teflon washer compression set for glass side
NEMORBT	Set "O" Ring for Gas Bulb Manifold #713076
NEMORGT	Set "O" Ring for Gas Transfer Manifold #713075

Lead Glass Stopcocks

Made in USA

EGL Stopcocks are used by virtually all neon shops in the United States and in many shops overseas.

ITEM NO.	DIAMETER
NSC2	2mm
NSC4	4mm
NSC6	6mm
NSC8	8mm
NSC10	10mm

Dow Corning High Vacuum Grease

5.3 oz.

ITEM NO. NDCSCG



Bombarders & Chokes



Bombarder Transformers

15 KVA Bombarder Transformers are suitable for use with all applications, and are generally the recommended choice for this reason.

22 KVA models are best suited for large scale, full-time production shops processing 15-25 mm tubing and using primarily 60-120 milliamp electrodes.

The EGL model 4600 variable-controlled choke is a DC reactance device using a dial Variac. When used in conjunction with the EGL milliamp gauge (item no. 733300) the model 4600 will provide precise control of bombarding levels combined with ease of operation and reliability.



BOMBARDER TRANSFORMER SPECIFICATIONS

MODEL	PRIMARY VOLT ¹	PRIMARY NOMINAL AMPS	PRIMARY PEAK AMPS	MINIMUM BREAKER SIZE ²	MINIMUM WIRE SIZE ³	SECONDARY VOLTS NOMINAL/PEAK	AVERAGE NOMINAL MA	PEAK MA	BOMBARDER DUTY CYCLES
15 KVA	240	10-80	100	100A	#2	26KV/24KV	800	1500	100%
22 KVA	240	10-80	100	100A	#2	26KV/24KV	800	1750	100%

1 - 208V services will draw approximately 10% more.

2 - Minimum 100 Amp service recommended.

3 - Minimum size included for wire and breaker suitable for most applications. For heavy, continuous production, use next-size-larger wire and breaker minimums.

CHOKES, BOMBARDERS & VARIACS

MODEL	CHOKE ONLY	BOMBARDER ONLY	VARIAC ONLY	CHOKE COMPLETE Includes Choke & Variac	BOMBARDER COMPLETE Incl. Choke Bombarder & Variac
15 KVA 220V/60Hz	718615	716615	718815	718620	716435
15 KVA 220V/50Hz	718515	716515	718806	718630	718550
22 KVA 220V/60Hz	718622	716622	718815	718660	718445
22 KVA 220V/50Hz*	718522	716522	718806	718525	718500

Bombarder Contactor (2-pole, 90 amp) includes main contactor assembly, metal enclosure and auxiliary contactor

ITEM NO. 718830

Contactor Foot Switch (10 amp, 500V), a heavy-duty single-pole, double-throw foot switch with guard. A 14 gauge SJ electrical cord with ground required for installation (not included).

ITEM NO. 718835

Digital Temperature Gauge

Designed for the neon bombarding process, this gauge provides accurate Fahrenheit or Celsius readings in a range of 32°F-650°F (0-325°C) and features a large, clear, 3/4" LCD, enabling the operator to concentrate fully on bombarding of units.

A high quality durable probe made for neon tubing (8-20mm diameter) with a foil thermocouple (replaceable) provides accurate temperature readings.

The unit is housed in a durable plastic case and comes equipped with one nine-volt battery for approximately 180 hours of operation

ITEM NO. 734200

Replacement Thermocouple

ITEM NO. 734210



Milliamp Gauge

The EGL Milliamp Gauge provides a reading of 0-1000 MA (1 AMP), and can be wired in series to indicate the precise power level drawn from the bombarding transformer. The gauge is simple to install and operates with any bombarder.

ITEM NO. 733300

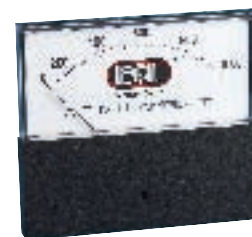

Manifolds

Manifold Systems

Precision® Manifold Systems by Daco

Precision® Manifold Systems are constructed with heavy wall PYREX® tubing and large bore, grease-free stopcocks. PYREX® offers superior outgassing properties and ease of cleaning compared to other glass and metal manifolds. Modular design provides the flexibility to match the manifold system to your requirements. Suitable for processing neon tubing as well as cold cathode lamps.

Single ended manifolds allow the operator to process either one or two units at a time. Double ended manifold systems allow the operator to alternate processing two units at a time from one side of the manifold to the other.

Precision® SE

The Precision® SE (single ended) manifold is constructed of 22mm borosilicate tubing with a 12mm main stopcock. The Precision SE can be set up for pumping from the right or left side. The double arm pumping attachment allows the operator to process either one or two units at a time. It may be adapted for use with a 0-40 Torr filling gauge. The Precision® SE can also be equipped with Gas Transfer Systems for use with metal canisters of gas.

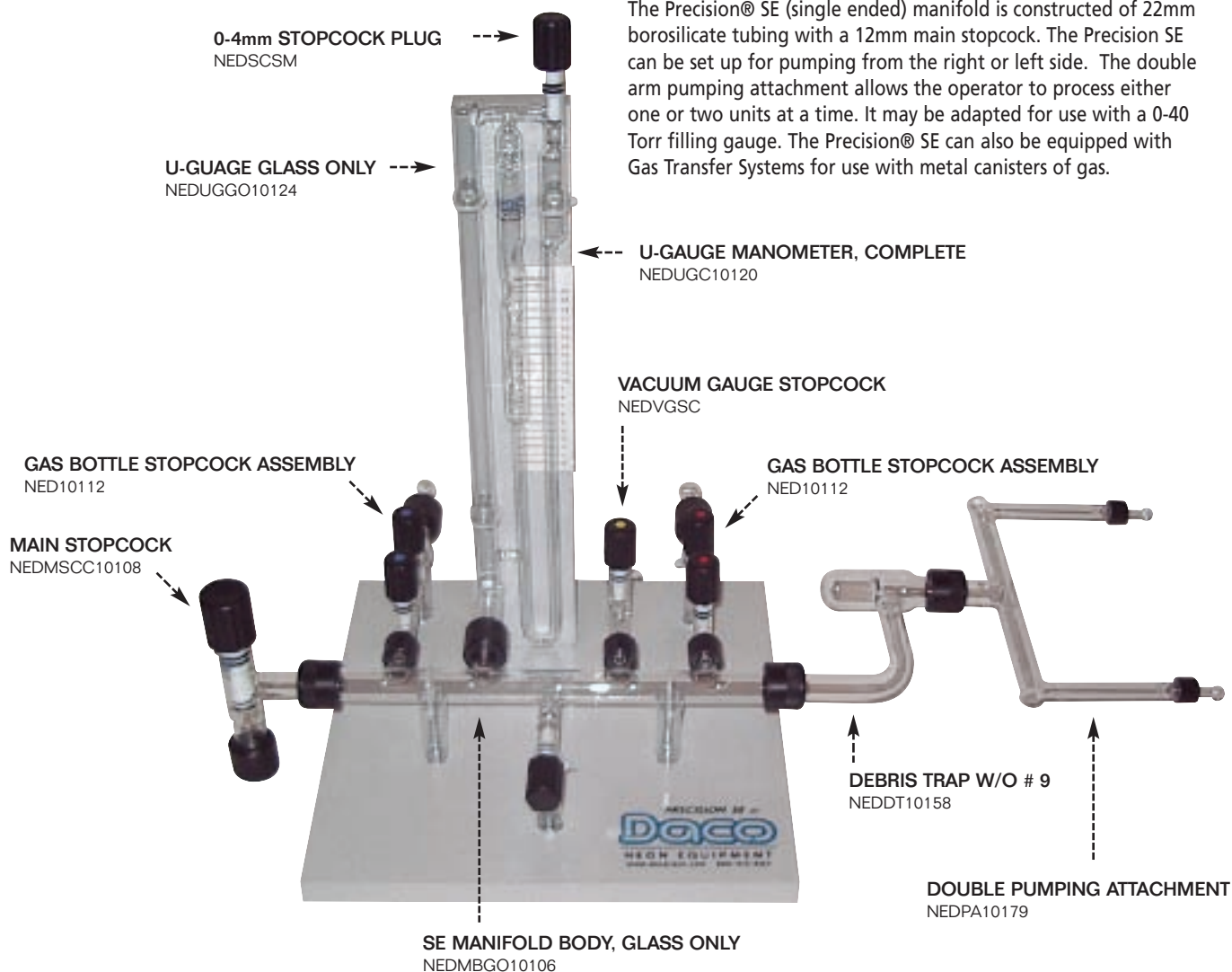

ITEM NO.	DESCRIPTION
NEDM10100	SE Manifold with U-Gauge Manometer & Gas Bottle Stopcocks
NEDM10102	SE Manifold with U-Gauge Manometer without Gas Bottle Stopcocks
NEDM10101	SE Manifold with 0-40 Torr Gauge & Gas Bottle Stopcocks
NEDM10103	SE Manifold with 0-40 Torr Gauge without Gas Bottle Stopcocks

Manifold Systems

DACO

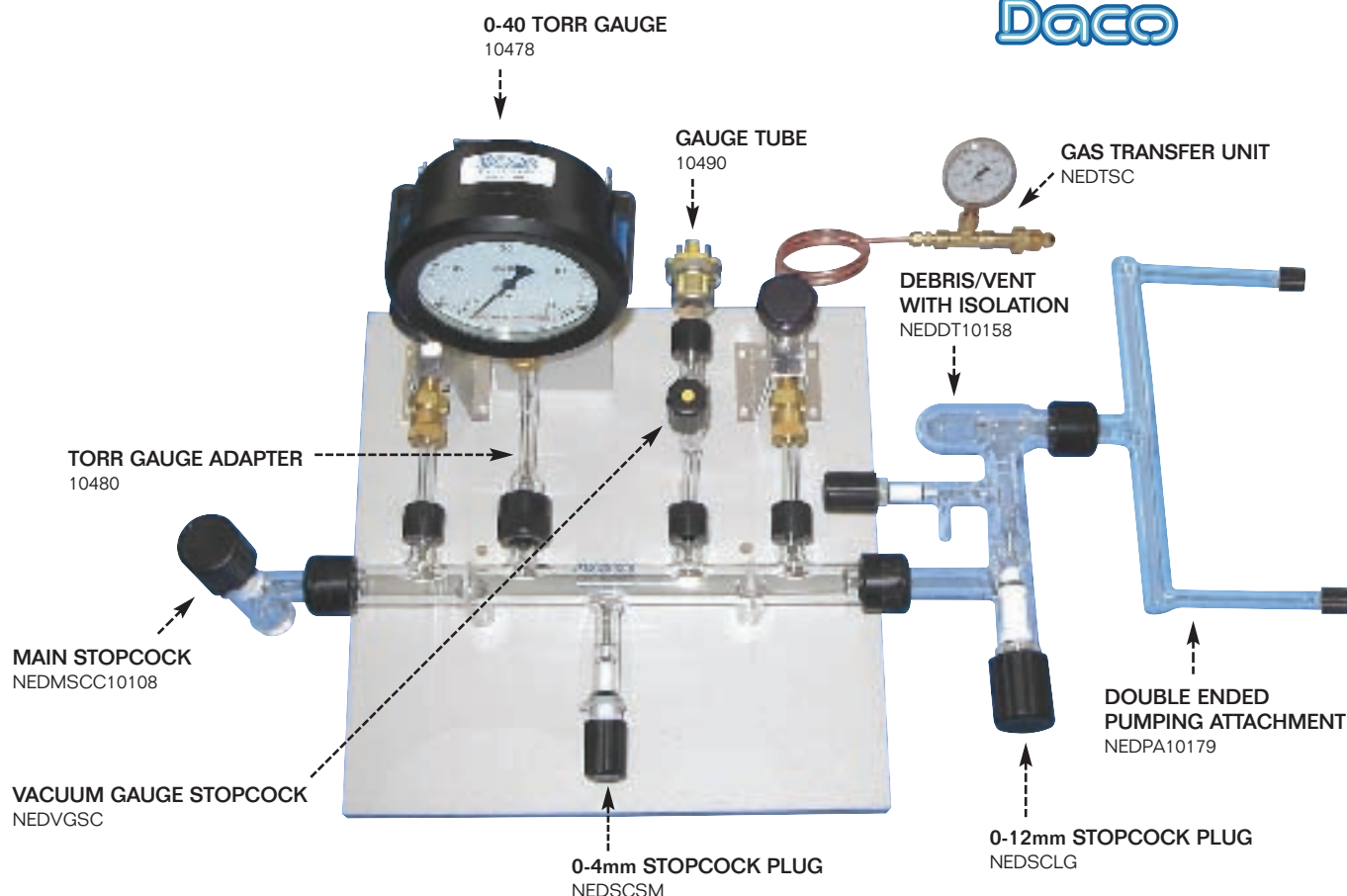

Standard Options Available:

Debris Trap for SE & DE Manifolds

ITEM NO.	DESCRIPTION
NEDDT10150	Prevents large particles from entering the manifold
NEDDT10152	For Precision II manifold
NEDDT10154	Debris Trap with 9mm connector includes port for a third gas bottle or transfer system
NEDDT10156	For Precision II manifold
NEDDT10158	Debris Trap with Isolation/Vent Valve isolates the pumping attachment and unit being processed from the manifold. Allows the operator to alternate processing from one side to the other.
NEDDT10160	For Precision II manifold
NEDDT10162	Debris Trap with Isolation/Vent Valve and port for a third gas
NEDDT10164	For Precision II manifold

Pumping Attachment for SE & DE Manifolds

Uses 7mm connector to allow attachment of 5 or 6mm tubulation to the manifold without welding or rubber hoses. Swivel arm moves up and down which makes the alignment with the tubulation easier and faster

ITEM NO.	DESCRIPTION
NEDPASEFA	Single ended with fixed arm #10166
NEDPA10168	For Precision II manifold
NEDPA10170	Single ended with swivel arm
NEDPA10179	Double ended with fixed arms #10179
NEDPA10181	For Precision II manifold
NEDPA10183	Double ended with swivel arms
NEDPA10185	For Precision II manifold
NEDPA10216	Double ended with fixed arm w/Roughing Pump Stopcock
NEDPA10215	For Precision II manifold
NEDPA10217	Double ended with swivel arm w/Roughing Pump Stopcock

Manifolds

Manifold Systems

Precision® DE

The Precision® DE (double ended) is constructed of 22mm tubing with a 12mm main stopcock. The DE is pictured with gas transfers, but can also be set up with gas flasks. The main stopcock is positioned in the middle of the manifold. The Precision® DE Manifold allows the operator to increase production by alternating from one side to the other.

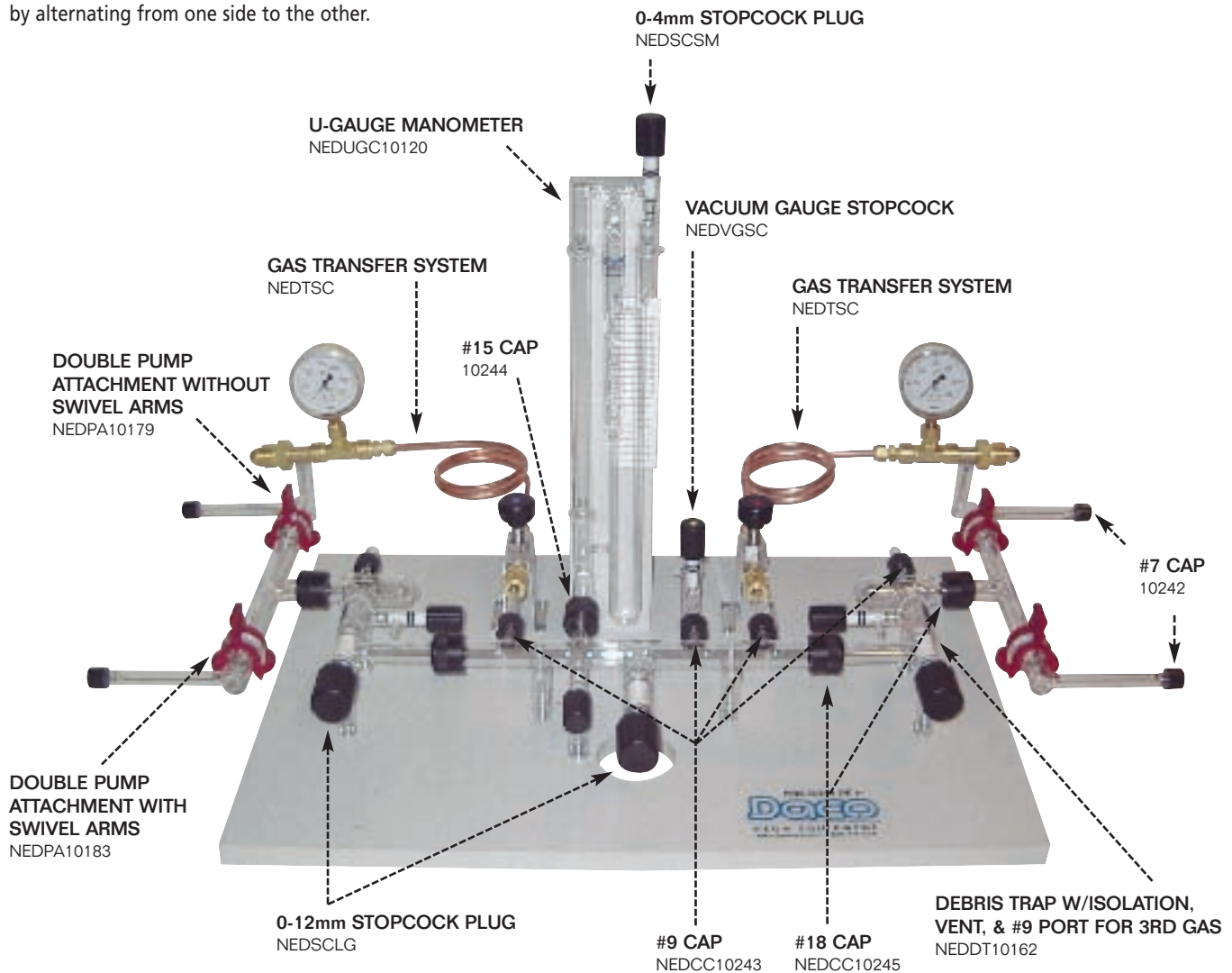

ITEM NO.	DESCRIPTION
NEDM10126	DE Manifold with U-Gauge Manometer & Gas Bottle Stopcocks
NEDM10128	DE Manifold with U-Gauge Manometer without Gas Bottle Stopcocks
NEDM10127	DE Manifold with 0-40 Torr Gauge & Gas Bottle Stopcocks
NEDM10129	DE Manifold with 0-40 Torr Gauge without Gas Bottle Stopcocks

Manifold Systems



Precision® II High Flow

The Precision® II High Flow Manifold is constructed of 28mm borosilicate tubing with a 20mm main stopcock. This high volume manifold provides extremely fast pumping speed and outstanding ultimate vacuum capability. The Precision II can be utilized as either a single sided or as a double sided system. With the double sided system the operator increases productivity by alternating two units at a time from one side of the manifold to the other. The Precision II manifold can be outfitted with a U-Gauge Manometer or 0-40 Torr Gauge and/or for use with metal canisters or gas flasks.

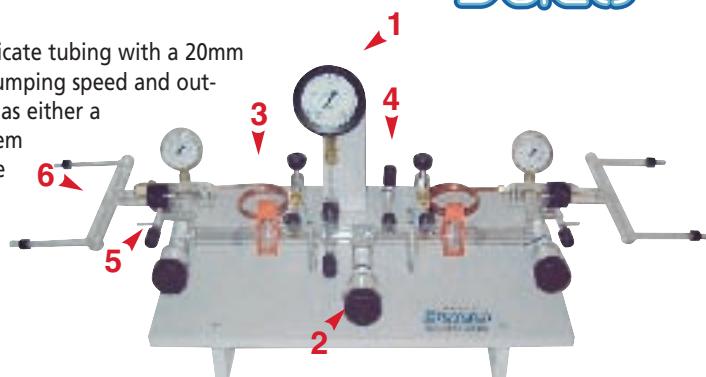

1. 0-40 Torr Capsule Fill Gauge*
2. Plug Main Stopcock (Included With Manifold)
3. Gas Transfer System
4. Vacuum Gauge Stopcock
5. Isolation Debris/Vent Trap
6. Double Ended Pumping Attachment with Fixed Arms

*U-Gauge Manometer also available

ITEM NO.	DESCRIPTION
10134	Manifold with U-Gauge Manometer & Gas Bottle Stopcocks
10136	Manifold with U-Gauge Manometer without Gas Bottle Stopcocks
10135	Manifold with 0-40 Torr Gauge & Gas Bottle Stopcocks
10137	Manifold with 0-40 Torr Gauge without Gas Bottle Stopcocks

Gas Transfer System

Meters the gas from metal canisters. Can be used with any Precision Manifold or adapted to other manifolds.

ITEM NO. NEDTSC

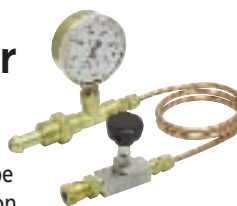

Vacuum Gauge Stopcock

Isolates the vacuum gauge while bombarding. Also protects the gauge tube from influx of contaminants. Accepts standard 1/8 NPT gauge tubes.

ITEM NO. NEDVGSC



U-Gauge Fluid Clear

ITEM NO.	SIZE
NEDUGF15CC	15cc
NEDUGF30CC	30cc



U-Gauge Manometer, Complete

Includes Glass, Stopcock, Mounting Board & Brackets. The most accurate method for measuring fill pressure.

ITEM NO. NEDUGC10120



Gas Bottle Stopcock Assembly, Complete

Meters the gas from glass flasks.

ITEM NO. NED10112



Butyl Phthalate Oil Red, 2oz

ITEM NO. NRBPO



U-Gauge Glass only

ITEM NO. NEDUGGO10124

0-40 Torr Capsule Fill Gauge

Easy-to-read analog gauge. Provides the operator continuous pressure readings during bombarding and for gas filling. Can be retrofitted to any Precision Manifold or to other manifolds.

ITEM NO. 10478



Gas Bottle Breaker Bars

Used for breaking the seal on glass flasks. Glass enclosed breaker bars eliminate the metal outgassing and contaminating the rare gas bottle.

ITEM NO. 10188

O-Ring Lubricant, 5ml

ITEM NO. NEDORL10191

Accessories & Replacement Glass for Manifolds:

ITEM NO.	DESCRIPTION
10106	SE Manifold Glass Body only
NEDMSCC10108	Main Stopcock Complete, Glass, Stopcock Plug, Cap & O'ring
10110	Main Stopcock SE Glass only
10132	DE Manifold Glass Body only
NEDSCSM	Plug for DE Main Stop Cock
NEDSCLG	0-12mm Stopcock Plug, complete
10141	0-20mm Stopcock Plug, complete
10257	O'ring Kit, for Manifold w/U-Gauge Gas Bottle Stopcock
NEDORS10258	O'ring Kit, for Manifold w/U-Gauge, without Gas Bottle Stopcock

Manifolds



Precision® Diffusion Pump Systems

The Precision® Diffusion Pump is a high performance, high vacuum secondary pump specifically designed and manufactured for neon and cold cathode production. The Diffusion Pump can be easily adapted to fit any pumping system and will improve the performance of virtually every vacuum pump. It works in unison with the mechanical vacuum pump producing higher pumping speeds and better ultimate vacuums, especially at low pressures when more performance is needed. Most importantly, the faster pumping speed and better vacuum achieved with a Diffusion Pump help produce a cleaner, longer lasting tube.

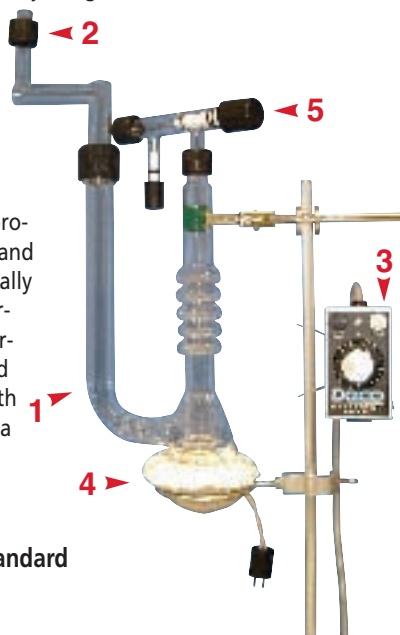

1. Diffusion Pump Body, Standard
2. Adapter to Manifold
(sold separately)
3. Heater Control
4. Heater
5. Isolation/Vent Valve
(sold separately)

Replacement Glass:
Diffusion Pump Glass Only

Options Available:

Diffusion Pump Standard

has an 18mm port to the vacuum pump and 25mm port to the manifold. Designed for use with the Precision® SE and Precision® DE Manifolds. May be adapted to any other manifold.

Diffusion Pump High Flow

has a 25mm port to the vacuum pump and manifold. Designed for use with the Precision II High Flow Manifold. May be adapted to any other manifold.

Diffusion Pump Isolation/Vent Valve

allows the system to remain under vacuum when not in use while venting the vacuum pump.

Diffusion Pump to Manifold Adapter

allows connection between the diffusion pump and manifold.

ITEM NO.	DESCRIPTION
NEDDP10453	Diffusion Pump, Standard
NEDDP10453-1	Diffusion Pump, 230 Volt
NEDDP1V10456	Diffusion Pump Isolation/Vent Valve, Standard
NEDDPA10458	Diffusion Pump to Manifold Adapter, Standard
10459	Diffusion Pump to Manifold Adapter w/18mm Connector for other Manifolds
10470	Diffusion Pump, High Flow
10456	Diffusion Pump Isolation/Vent Valve, High Flow
10458	Diffusion Pump to Manifold Adapter, High Flow
10468	Fluid Diffusion Pump #704-50cc
10469	Fluid Diffusion Pump #704-100cc

Precision® Vacuum Gauges

Allows the operator to precisely monitor vacuum levels after bombarding. These gauges include rugged but sensitive gauge tubes for excellent stability, accuracy, and reliability. Good to determine ultimate vacuum, slight leaks, outgassing, and integrity of the system.



ITEM NO.	MODEL	DESCRIPTION
10486	Vacuum Gauge II	RANGE: 0 - 100 Microns Good for cold cathode and all neon applications. Accuracy rating is ±1% AMD (@ 1 is ±.2).
NEDPVG10489	Vacuum Gauge III	RANGE: 0 - 1,000 Microns Good for all neon applications to determine if manifold consistently pulls below 5 microns. Accuracy rating is ±2% AMD (@ 5 is ±1.5).

Digital Vacuum Gauge

Compact battery powered unit with fast, accurate, and easy-to-read digital display. Includes battery and is mounted in a rugged free-standing case. Good for all neon applications.



RANGE: 0 - 200 Microns
ITEM NO. NEDDVG10497

Caution:

With all vacuum gauges, a stopcock should be installed between the manifold and vacuum gauge tube in order to isolate the vacuum gauge from the manifold during bombarding. This stopcock also protects the gauge tube from any influx of contaminants when venting the manifold to atmosphere.



Vacuum Pumps

All EGL vacuum pumps are 2-stage rotary vane direct-drive pumps which reach an ultimate vacuum of 1×10^{-4} mbar and have ISO-KF-25 flanges on inlets and outlets. All have anti-suckback valves and are equipped with Pneurop flanges, hose nipple, centering ring, O-ring, and clamp.

VACUUM PUMP SPECIFICATIONS			
	SERIES A32	SERIES A70	SERIES A107
ITEM NO.	721300	721400	721200
Free Air Displacement CFM(L/min) 3.2 (90)	3.2 (90)	7.0 (195)	10.7 (305)
Oil Capacity Quarts	0.825	1.0	1.0
Motor Rating (hp/rpm)	1/3-1800	1/2-1800	3/4-1800
Weight (Approx.) lbs(kg)	48 (22)	55 (24.5)	63 (28.6)
Voltage/cycles	110V/50/60Hz and 220V/50/60Hz	110V/50/60Hz and 220V/50/60Hz	110V/50/60Hz and 220V/50/60Hz
Mist Eliminator (optional)	720915	720915	720915



High vacuum pumps designed for many years of dependable, highly effective service. Ideal for neon processing, these two-stage rotary vane pumps provide stable pumping efficiency even in the low micron range. Available in both belt drive and direct drive in 115 or 230 volt models, they are built for long life and ease of maintenance.

ITEM NO.	DESCRIPTION	
NEDVP1402	5.6CFM (160L/min)	Welch 1402 Belt Drive with Air Breather
VP96	10.6CFM (300L/min)	Welch 1376 Belt Drive with Air Breather
VP97	17.7CFM (500L/min)	Welch 1397 Belt Drive with Standard Filter
VP99	3.8CFM (108L/min)	Welch 8912 Direct Drive without Filter
VP100	6.1CFM (173L/min)	Welch 8917 Direct Drive without Filter
NEDVP101	7.7CFM (218L/min)	Welch 8920 Direct Drive without Filter
VP103	11.3CFM (320L/min)	Welch 8925 Direct Drive without Filter



Flushing Oil

Swift, safe removal of harmful sediment and contamination from high vacuum pumps is accomplished by using this specially developed oil. One or two flushings clean accumulated residues and protect the pump. Its use considerably improves high vacuum production. The pump can be refilled with operating oil immediately after flushing. This oil is for flushing only, and should not be used for high vacuum operation. 1 Gallon

ITEM NO. NFOG

High Vacuum Hose for Vacuum Pumping Systems

5/8" ID x 1/2" Wall, latex
ITEM NO. 723000

1/2" ID x 1/2" Wall, latex
ITEM NO. 723500

3/4" ID x 1/2" Wall, pure gum
ITEM NO. NEPG34X12

3/8" ID x 3/8" Wall, pure gum
ITEM NO. 724500

1/2" ID x 3/8" Wall, pure gum
ITEM NO. 725500



Metra 19 Vacuum Pump Oil

For direct-drive vacuum pumps

A distilled hydrocarbon oil with good ultimate vacuum and low back streaming. It is an ideal oil for most direct-drive rotary vane vacuum pumps. 1 Gallon

ITEM NO. NVPOG



Metra 1 Vacuum Pump Oil

For belt-drive vacuum pumps

A highly refined general purpose hydrocarbon mineral oil recommended for most belt-drive rotary vane vacuum pumps. 1 Gallon

ITEM NO. NVPO1G



Bombarding

Bombarders & Chokes



Bombarders, Chokes & Prewire Units

Daco Bombarders and Chokes are suitable for all applications in a full range of sizes from 5KVA to 15KVA. All bombarders require 208-240 line voltage. Sliding Core Chokes are available to match each size bombarder or the Chokemaster Variac Choke controls all bombarders up through 15KVA. The Prewire Unit (safety switch) prevents accidental activation of the bombarder. The Prewire is ready for easy installation and includes a magnetic contactor with a choice of either thumb switch or foot switch.

Bombarders

ITEM NO.	SIZE	SECONDARY VOLTAGE	LINE LOAD AMPS
NEDB5K15V	5 KVA	15000	20.8
NEDB7.5K15V	7.5 KVA	15000	31.2
NEDB10K15V	10 KVA	15000	41.6
NEDB12.5K15V	12.5 KVA	15000	52.0
NEDB12.5K23.5V	12.5 KVA	23500	52.0
NEDB15K15V	15 KVA	15000	62.5
NEDB15K20V	15 KVA	20000	62.5



Chokes

ITEM NO.	SIZE	SECONDARY VOLTAGE	LINE LOAD AMPS
NEDC5K15V	5 KVA	15000	
NEDC7.5K15V	7.5 KVA	15000	
NEDC10K15V	10 KVA	15000	41.6
NEDC12.5K15V	12.5 KVA	15000	52.0
NEDC15K15V	15 KVA	15000	62.5
NEDC10K20V	10 KVA	20000	41.6
NEDC12.5K20V	12.5 KVA	20000	
NEDC12.5K23.5V	12.5 KVA	23500	52.0
NEDC15K20V	15 KVA	20000	62.5



Prewire Units

ITEM NO.	DESCRIPTION
NEDPWWS	Prewire unit with Magnetic Contactor & Thumb Switch
NEDPWWFS	Prewire unit with Magnetic Contactor & Foot Switch

Chokemaster Variac Choke

The Chokemaster Variac Choke is a DC reactance choke controlled by a 10 amp variac. It provides precise control of the bombarding current by simply turning the dial on the variac to the desired level. The Chokemaster controls any bombarder up to 15KVA over a continuous range from 20% to 100% of output.

ITEM NO. NEDC10616

10 Amp Dial Control Variac

ITEM NO. 10640



Bombarding Temperature Gauge



Monitors the glass temperature of the tube during the bombarding cycle to:

- Ensure that glass temperature is high enough for sufficient degassing;
- Prevent the tubing from being overheated, which may damage the phosphor powders and cause deformation of the glass; and
- Monitor glass cool down temperatures in correlation with vacuum levels obtained during pump down.



Shows either Centigrade or Fahrenheit on easy-to-read digital display.

ITEM NO. NEDTGT

Bombarding Milliamp Meter



Precisely monitors bombarding current levels from 0 - 1,000 MA. Allows processing exactly to the electrode manufacturer's specifications for best possible results when used with the Bombarding Temperature Gauge.



ITEM NO. NEDBMM

Gasses



All EGL gases are of the highest quality: 99.999% pure

EGL standard and blended gas mixtures are shipped in hard or soft glass flasks in Jumbo (2.65 liter) and Regular (1.25 liter) sizes as shown below. All gases are bottled in a completely new rare gas plant, using state-of-the-art apparatus and techniques.

Also available is a complete gas transfer system for use with 25, 50, or 100 liter EGL disposable gas tanks.



EGL Neon (Red)

Excellent for clear red units, or for coated tubing

ITEM NO.	EGL PART NO.	DESCRIPTION	VOLUME (LITERS)
NGR	412000	Soft Glass (lead)	.90
NGRHG1	416000	Hard Glass (Pyrex®)	1
NGRSG	420000	Soft Glass (lead)	2.65
NGRHG2	424000	Hard Glass (Pyrex®)	2
NGR25	436000	Tank	25
NGR50	440000	Tank	50
NGR100	444000	Tank	100

EGL Argon (Blue)

For low-voltage fluorescent tubes and fluorescent lamps. Mercury required. Not recommended for outdoor use.

ITEM NO.	EGL PART NO.	DESCRIPTION	VOLUME (LITERS)
NGA	413000	Soft Glass (lead)	.90
NGAHG1	417000	Hard Glass (Pyrex®)	1
NGASG	421000	Soft Glass (lead)	2.65
NGAHG2	425000	Hard Glass (Pyrex®)	2
NGA25	437000	Tank	25
NGA50	441000	Tank	50
NGA100	445000	Tank	100

EGL Blue (Replaces #1050)

EGL's standard mixture for warmer climates - used in clear or fluorescent-coated tubing with added mercury.

ITEM NO.	EGL PART NO.	DESCRIPTION	VOLUME (LITERS)
NGB	411001	Soft Glass (lead)	.90
NGBHG1	415000	Hard Glass (Pyrex®)	1
NGBSG	419000	Soft Glass (lead)	2.65
NGBHG2	423000	Hard Glass (Pyrex®)	2
NGB25	435000	Tank	25
NGB50	439000	Tank	50
NGB100	443000	Tank	100

EGL K4 Cold Weather Gas (Blue)

The best for all-weather applications, from below-zero regions to the tropics. The high percentage of Ne in K4 provides the heat necessary to completely vaporize mercury under cold weather conditions. Mercury required. Proven 14 to 49% brighter than competitive cold weather gases by independent laboratory.

ITEM NO.	EGL PART NO.	DESCRIPTION	VOLUME (LITERS)
NGK4	414000	Soft Glass (lead)	.90
NGK4HG1	418000	Hard Glass (Pyrex®)	1
NGK4SG	422000	Soft Glass (lead)	2.65
NGK4HG2	426000	Hard Glass (Pyrex®)	2
NGK425	438000	Tank	25
NGK450	442000	Tank	50
NGK4100	446000	Tank	100

EGL Flushing Helium

The finest and safest gas for preliminary bombarding, or for flushing-out repair units.

ITEM NO.	DESCRIPTION	VOLUME (LITERS)
NGFH	429000	Soft Glass (lead)
NGFHHG1	430000	Hard Glass (Pyrex®)
NGFHSG	426175	Soft Glass (lead)
NGFH25	438800	Tank
NGFH50	442200	Tank
NGFH100	445600	Tank



Spectra Gas Neon (Red)

ITEM NO.	DESCRIPTION	VOLUME (LITERS)
NDGN12	Spectra Gas Neon	12
NDGN20	Spectra Gas Neon	20
NDGN50	Spectra Gas Neon	50
NDGN100	Spectra Gas Neon	100

Spectra Gas Mixed (Blue)

Argon 45%, Balance Neon

ITEM NO.	DESCRIPTION	VOLUME (LITERS)
NDGM20	Spectra Gas Mixed	20
NDGM50	Spectra Gas Mixed	50

Spectra Gas K-4 (Blue)

Argon 25%, Balance Neon

ITEM NO.	DESCRIPTION	VOLUME (LITERS)
NDGK412	Spectra Gas K-4	12
NDGK420	Spectra Gas K-4	20
NDGK450	Spectra Gas K-4	50
NDGK4100	Spectra Gas K-4	100

Gasses

Gas (BTU) Ratings / Air (CFH) Ratings

Mixer sized refer to the orifice in the Venturi mixers. Mixers are sized to each fire

5 Point Crossfire Natural and Artificial
BMT 7 Crossfire Natural and Artificial
S-21-N Crossfire Natural and Artificial

#3141 Mixer
#2230 Mixer
#1929 Mixer

BTU RATINGS	GAS BTU	CFH GAS (CUBIC FT/HR)	CFH AIR (CUBIC FT/HR)	CFM AIR (CUBIC FT/MIN)
790 JCN 5 point	20,000	19.25	150	2.5
BMT 7	25,000	24	200	3.33
S-21-N	50,000	48	400	6.66
16" RB	116,000	111	1115	18.58
24" RB	178,000	170	1200	20
#1 Torch	6,000	6	50	.83
#2 Torch	4,000	4	50	.83
#3 Torch	4,000	4	50	.83

Note: The above consumption chart is for natural gas.

Artificial (Manufactured) Gas (Propane)

1. The air pressure and volume is the same specification as per the chart above.
2. The CFH (cubic feet per hour) for artificial gas is double that in the chart above.
Example: 1-16" Ribbon Burner = 111 CFH Natural Gas. Artificial Gas is 222 CFH.

CAUTION: All gas supplies and systems should be installed and checked by a licensed gas fitter for safety purposes.

- Natural Gas has 1000 BTU per cubic foot
- BTU stands for British Thermal Unit.
- One BTU is equivalent to the heat required to raise the temperature of 1 pound of water from 59 degrees to 60 degrees Fahrenheit.

Ribbon Burners

Ribbon burners are utilized for creating sweeping curve effects and script-type lettering for neon signs. EGL Ribbon Burners feature a brass burner bar to eliminate warping and side ignition, and an improved economizer valve with O-ring seals to eliminate leakage.

All models are equipped with a control slide to adjust flame length. The cast aluminum body rotates 360 on a collar flange which can be bolted on a workbench, or threaded onto an available pipe stand with 17-pound weighted base plate.



16" Ribbon Burner



24" Ribbon Burner w/Stand

Automatic Ribbon Fire

The AUTOMATIC RIBBON FIRE is a stand-alone unit which has its own air supply. Simply connect the gas and plug in to 115 volt circuit. Automatically ignites when the foot switch is depressed, then shuts down when the switch is depressed a second time. Minimizes gas consumption and reduces heat buildup in your shop.

ITEM NO. NEDARB10726



Complete System includes economizer and bench flange

ITEM NO.	DESCRIPTION	BURNER TIP
NERB16NC	16" Ribbon Burner, complete with Stand	Natural Gas
664103	16" Ribbon Burner, complete with Stand	Artificial Gas
NERB16NNS	16" Ribbon Burner, complete without Stand	Natural Gas
NERB16ANS	16" Ribbon Burner, complete without Stand	Artificial Gas
658001	24" Ribbon Burner, complete with Stand	Natural Gas
658501	24" Ribbon Burner, complete with Stand	Artificial Gas
NERB24NC	24" Ribbon Burner, complete without Stand	Natural Gas
NERB24AC	24" Ribbon Burner, complete without Stand	Artificial Gas

ITEM NO.	DESCRIPTION	BURNER TIP
NERB16NH	16" Ribbon Burner Head	Natural Gas
NERB16AH	16" Ribbon Burner Head	Artificial Gas
659000	24" Ribbon Burner Head	Natural Gas
659500	24" Ribbon Burner Head	Artificial Gas
664325	16" Screens	Natural Gas
664320	16" Screens	Artificial Gas
663100	24" Screens	Natural Gas
663000	24" Screens	Artificial Gas

ITEM NO.	DESCRIPTION
NERB16SLIDE	16" Slide
NERB12SLIDES	12" Slides (2)
664300	Bench/Stand Flange
NERBST	Floor Stand
NERBEC	Economizer

Glass Bending

Cannon-Fire Crossfires



Cannon-fire Crossfire shown with optional Swing-Out Burner

BMT-7 Series

Provides a knife-shape flame, ideal for splicing and sufficient heat for bending glass 15mm or less

Complete System includes burners, side pipes, sliding base, T-splitter, and 1/4" Venturi mixer

Burner Tip BMT-7

ITEM NO.	DESCRIPTION
NCFBMT7CS	Complete System with Stand
NCFBMT7CNS	Complete System without Stand
NCFSOBC	Complete System with Swing-Out Burner
NCFTBMT7	Burner Tip
NCFSPBMT7	Side Pipe
NCFRBMT7	Reducer
NCFTS	T-Splitter
	Stand

S21 Series

Provides a broad, high-heat flame hotter than 5-point crossfires but more diffused, hence better for bending than splicing.

Complete System includes burners, side pipes, sliding base, T-splitter, and 1/4" Venturi mixer

Burner Tip S21

ITEM NO.	DESCRIPTION
653051 S21N	Complete System with Stand
653000 S21N	Complete System without Stand
653551 S21A	Complete System with Stand
653500 S21A	Complete System without Stand
NCCTS21N	Burner Tip Natural Gas
NCCTS21A	Burner Tip Artificial Gas
NCFSPBMT7	Side Pipe
NCFTS	T-Splitter
	Stand

Mixers

Series BMT-7 (#676300) complete

ITEM NO. NCFBMT7

SERIES S21 (#677000) complete

ITEM NO. NCFMS21

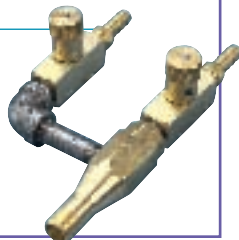

5-Point Crossfires



5-Point Crossfire shown with optional Swing-Out Burner

790 JC Series

Provides an even heat output system to bend or splice all diameters, from 8mm to 35mm.

Complete System includes burners, side pipes, sliding base, T-splitter, and 1/4" Venturi mixer

ITEM NO.	DESCRIPTION
NCFNCWS	Complete System with Stand, Natural Gas Tip
NCF790JCNS	Complete System without Stand, Natural Gas Tip
651551 790 JC A	Complete System with Stand, Artificial Gas Tip
651500 790 JC A	Complete System without Stand, Artificial Gas Tip
NCFT790JCN	Burner Tip, Natural Gas
NCFT790JCA	Burner Tip, Artificial Gas
NCFSP790JC	Side Pipe for 790 JC
NCFTS	T-Splitter
	Stand



Manifold with Burner Tips

T-Splitter

5-Point Crossfire Manifolds

ITEM NO.	DESCRIPTION
674200 N	Manifold with Burner Tips
674100 A	Manifold with Burner Tips
674000	Manifold Casting Only
655530	Brass Elbow

Mixer

Series 790-JC/BMT-71/4 (#675000)

ITEM NO. NCFM790JC



Hand Torches

Torch No. 1

Splicing torch with #81 oblong "fishtail" burners for splicing 10-25 mm glass.

ITEM NO.	SPACE BET. BURNERS	BURNER TIP
NHT1	2"	Natural or Artificial Gas

Brass Fishtail Burner Tips

for Torch No. 1 (1/4" MPT)

ITEM NO.	BURNER TIP
NHTT81N	Natural or Artificial Gas

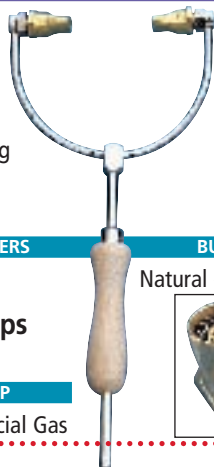

Torch No. 2

Combination Splicing/Tipping torch with #228 oblong "fishtail" burners for splicing smaller diameter glass (up to 13mm), and for tipping off with reduced flame.

ITEM NO.	SPACE BET. BURNERS	BURNER TIP
NHT2N	1 1/2"	228-Natural Gas
NHT2A	1 1/2"	228-Artificial Gas

Brass Fishtail Burner Tips

for Torch No. 2

ITEM NO.	BURNER TIP
NHTT228N	228-Natural Gas
NHTT228A	228-Artificial Gas



Torch No. 3

Tipping torch with #228 oblong "fishtail" brass burners for tipping off tubes up 6mm diameter. May also be used for splicing tubes up to 10mm.

ITEM NO.	SPACE BET. BURNERS	BURNER TIP
NHT3N	1 1/2"	Natural Gas
NHT3A	1 1/2"	Artificial Gas

Brass Fishtail Burner Tips

for Torch No. 3 (1/4"-27 Thread)

ITEM NO.	BURNER TIP
NHTT228N	228-Natural Gas
NHTT228A	228-Artificial Gas



Brass Round Burner Tips

for Torch No. 3 (1/4"-27 Thread)

ITEM NO.	BURNER TIP
667540	100ST-Natural or Gas



Needle Valve, 1/8"

ITEM NO. 682000

Mixer 44-50 1/8"

ITEM NO. NEVMC

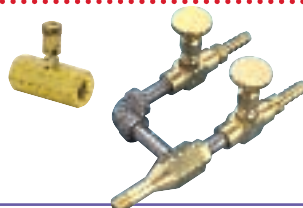

Torch No. 500

Tipping torch with round burners for tipping off tubes up to 6mm diameter. May also be used for splicing tubes up to 10mm. Replaceable stainless steel tips enable the torch body to be reused indefinitely.

ITEM NO.	SPACE BET. BURNERS	BURNER TIP
650970	1 1/2"	100-Natural Gas
	1 1/2"	100-Artificial Gas

Stainless Steel Round Burner Tips

for Torch No. 500 (1/4" MPT)

ITEM NO.	BURNER TIP
667545	100ST-Natural or Gas

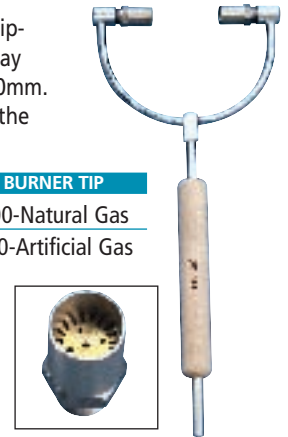

Swivels

3/16" Swivels are most commonly used for neon tubing; 1/4" are best suited for cold cathode work (18 mm and larger).

ITEM NO.	SWIVEL	ANGLE
NESW14RAOS	1/4"	Right Angle, One-sided
NESW316GRADS	3/16"	Right Angle, Double
NESW316RAOS	3/16"	Right Angle, One-sided
NESW14112ST	1/4" x 1 1/2"	Straight
NESW143ST	1/4" x 3"	Straight

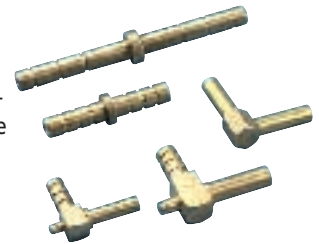

Natural Latex Tubing

for Gas and Air Supply Lines

Hand Torch Hose

1/4" ID x 3/32" Wall
ITEM NO. NELT14332

Crossfire Hose

3/8" ID x 3/32" Wall
ITEM NO. NELT38332

1/2" ID x 3/32" Wall
ITEM NO. NELT12332

Blow Hose

1/8" ID x 1/16" Wall
ITEM NO. NELT18116

3/16" ID x 1/16" Wall
ITEM NO. NELT316116

3/16" ID x 1/32" Wall
ITEM NO. NELT316132

Ribbon Burner Hose

1/2" ID x 3/32" Wall
ITEM NO. NELT12332

5/8" ID x 1/8" Wall
ITEM NO. NELT5818

Blow Hose Adaptor Kit

ITEM NO. NEDBHK



Glass Bending

Air/Gas Manifold

A completely assembled unit providing air and gas to the ribbon fire, cross fire, and hand torch. Consists of air and gas valves for the ribbon fire, venturi mixers for the cross fire and hand torch, all plumbing, and brackets for wall or bench mount. Use with either natural gas or propane. May be adapted to accept more than three fires.

ITEM NO. 10755

Venturi mixers and valves may be purchased separately.

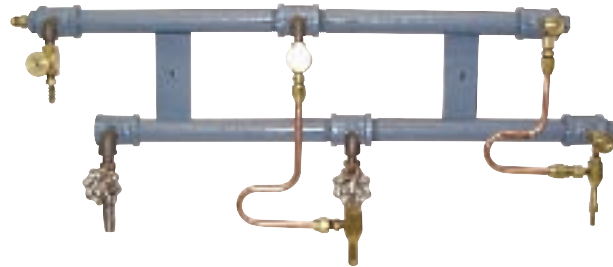

Regenerative Blowers

- Rugged construction, low maintenance
- Oilless operation
- UL and CSA approved TEFC motors with permanently sealed ball bearings
- Automatic restart thermal protection on single phase motors
- Aluminum blower housing, impeller and cover
- Can be operated with no air flow through unit
- Can be mounted in any plane
- Inlet and outlet have internal muffling



Filters

ITEM NO.	DESCRIPTION
NABAJ126B	For Blower #R2103
NABAJ126C	For Blower #R3105-1
NABAJ126D	For Blower #R4110-2
NABAJ151D	For Blower #R4 & R5



Mufflers

ITEM NO.	DESCRIPTION
NABAJ121B	For Blower #R2103
NABAJ121C	For Blower #R3105-1
NABAJ121D	For Blower #R4 & R5

Blowers

ITEM NO.	MODEL	MAX. PRESSURE	MAX. VACUUM	MAX. AIR FLOW
NAB2103	R2103	39" H ₂ O (60 Hz), 30" H ₂ O (50 Hz)	35" H ₂ O (60 Hz), 25" H ₂ O (50 Hz)	42 CFM (60 Hz), 33 CFM (50 Hz)
NAB3105-1	R3105-1	43" H ₂ O (60 Hz), 31" H ₂ O (50 Hz)	40" H ₂ O (60 Hz), 28" H ₂ O (50 Hz)	53 CFM (60 Hz), 44 CFM (50 Hz)
NAB4110-2	R4110-2	52" H ₂ O (60 Hz), 38" H ₂ O (50 Hz)	48" H ₂ O (60 Hz), 35" H ₂ O (50 Hz)	92 CFM (60 Hz), 75 CFM (50 Hz)
NAB5125-2	R5125-2	65" H ₂ O (60 Hz), 50" H ₂ O (50 Hz)	60" H ₂ O (60 Hz), 47" H ₂ O (50 Hz)	160 CFM (60 Hz), 133 CFM (50 Hz)

Spark Coil

110 or 230 Volt high-frequency generator used for detecting leaks in a pumping system. BD 10A is a standard product for lab use and is available with an on/off switch. Also available is BD 20A for more specialized uses, with its finer probe tip.



ITEM NO.	DESCRIPTION	VOLTS
NTCBD10	No switch	120V
NTCBD10S	With on/off switch	120V
NTCBDRT	Replacement Tip	

Portable Slimline Tube Tester w/Case

Battery powered high frequency generator for testing pumped neon tubes and fluorescent lamps, operates on 4 AA batteries. Tube being tested will illuminate in a pulsating manner if "good". Includes leather case. 6-7/8" long x 1-1/2" wide x 3/4" deep



ITEM NO. NTT

Rechargeable Tube Tester

Allows safe and easy testing of neon tubes and fluorescent lamps. The telescoping antenna allows easy access, even in hard-to-reach installations. Simply depress the On/Off switch and then touch the antenna to the unit. Ni-Cad battery and 115/230 volt recharging adapter included. Carry it with you on every service call.



ITEM NO. NTTR

Replacement Antenna

ITEM NO. NTTRA

UltraViolet Color Checker

A compact, lightweight 4 watt UV lamp for checking the color of phosphor coated tubing, the EGL color checker is housed in a high quality, impact-resistant ABS plastic case that resists fading, peeling and cracking from exposure to heat or chemicals.

6-1/2" long x 1-1/4" wide x 1-3/4" height, Weighs 8 oz., and uses 4 AA 1.5 volt batteries (not included)



ITEM NO. NCOT

Color Checker

Used to determine the color of the open tubing. Operates with batteries. The handle opens to provide a stand with a 360° rotation of the light source.



ITEM NO. NEDCOT11459

Load Milliamp Meter

Allows the factory and the installation personnel to determine the proper secondary voltage transformer required for each application. Great for field testing transformer loads on service calls. Includes a handy and durable carrying case.



ITEM NO. NEDLMM

Digital Map Measure

Used for measuring required lengths of glass tubing by following the exact contours of a to-scale working drawing of the intended design; also helps determine the strength of the voltage transformer to be used.

Scale Master Classic 6020

With 72 built-in scales

ITEM NO. NTM6020

Scale Master II 6130

With 91 built-in scales

ITEM NO. NTM6130



Electrode Holder

keeps fingers cool while splicing.

ITEM NO. NEH



Brass Electrode Holder

ITEM NO.	DIAMETER
NEHB10	10mm
NEHB12	12mm
NEHB15	15mm
NEHB18	18mm



Corks



ITEM NO.	DIAMETER
NC8	8mm
NC10	10mm
NC12	12mm
NC15	15mm

Mercury

Triple-distilled EGL mercury is the purest available anywhere. Packed in 1 lb. glass bottles.

ITEM NO. NME



Mercury Spill Kit

ITEM NO. NMESK

Mercury Injector

The EGL Mercury Injector improves operator safety and dispensing accuracy. Pressing a button advances a plunger, dispensing 10 micro-liters (100mg) of mercury, equivalent to a ball 2mm in diameter—the correct amount for most argon-filled "neon" tubes. The reservoir has a 500 microliter capacity, good for 50 applications.



ITEM NO. NMIN

Tools

Neon Electro Pounce Unit



Save time and money by simply drawing with this electric pencil rather than using outdated pounce wheels. Crisp, clean holes of various sizes can be easily pounced in one or many sheets of paper by simply adjusting the voltage dial.

The Electro Pounce comes complete with a standard 10 foot pounce cord and a dozen replacement needles. Cord assemblies are stocked in several additional standard lengths, and custom cords of nearly any length are available on a special order basis.

ITEM NO.	DESCRIPTION
NELPORN	Neon Electro Pounce Needles (Dozen)
NELPO	Neon Electro Pounce Unit

Neon Hand Block

- Used for flattening neon tube bends
- Clean – No harmful fumes
- Leaves no marking on neon tubing
- Withstands temperatures in excess of 1400 degrees F
- Available in 2 sizes



ITEM NO.	DIMENSIONS LxWxH
NHBSM	4 x 2½ x ¾
NHB	7½ x 3 x 1

6" Glass File

- High quality files
- Use for scoring neon tubing and smoothing cut edges
- Warding Bastard #1 cut File
- Double cut sides, Single cut edges



ITEM NO. NGF

Kitco Electric Tube Cutter

The Kitco Electric Glass Cutter provides smooth and easy cuts every time even for the most difficult cuts. Saves time and virtually eliminates hairline crack backs even when cutting on radius bends, near double backs, and on classic glass.

Four heat settings allow precise temperature control for even heating of the tube. Cutter includes 10, 12, 13, 15, and 20mm wire cutting loops. Extra wire loops are available in 8-25mm sizes. A second cutting handle can be added to switch glass sizes without changing the wire loop. Available in 115 and 230 volt models.

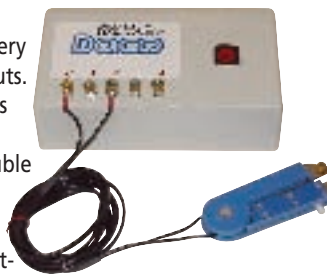

ITEM NO.	DESCRIPTION
10879	Electric Tube Cutter
10880	Cutter handle only
10882.1	Loops

Bombarding Mica

Used to put between glass while bombarding to protect from breaking.



ITEM NO. NMI

China Markers

ITEM NO.	COLOR
LYCMBK	Black
LYCMBL	Dark Blue
LYCMR	Red
LYCMW	White



Nonsbestos Material

- Translucent high temperature fabric
 - Little odor
 - Contains NO asbestos
 - Marks well with carbon papers or pen inks as well as friction feed plotters
 - Will withstand multiple "heats"
- 38" x 25 yard roll



ITEM NO. NNB

Pattern Paper; Burroughs 1" Grid

- Premium quality 70 lb kraft paper
 - 1" grid
 - 1/4" plot points
- 48" x 110 yard roll

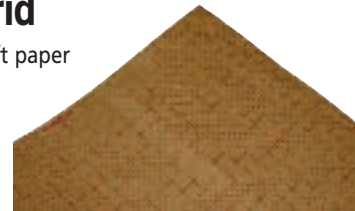

ITEM NO. NPPA

Acetone

Can be used to wash out manifolds.



ITEM NO. TSASG

Bronze Screen

Used to protect the pattern paper.



ITEM NO. NEDBS



**EGL's East Coast Master Distributor
of Neon Glass & Electrodes!**



EGL Tubing

World's Largest Color Selection!

EGL has introduced more new colors in the last 10 years than any other source — stunning, saturated colors that give your neon signage, channel letters and architectural lighting unequalled brilliance, uniformity and longevity.

For top performance and cost effectiveness in both general and specialized applications, EGL produces neon tubing of many types including:

- SIGNMATE™ Single-Coated Tubing
- SIGNMATE II™ Double-Coated Tubing
- ACCUWALL® Coated and Uncoated Colored Glass Tubing
- Rare Earth Phosphor Coated Tubing
- Tri-phosphor Coated Tubing
- Cold Cathode Tubing

Choose from one of the world's largest tubing color selections now in stock for immediate shipment, including colors comparable to other makers, but with superior batch-to-batch consistency. And no other neon producer provides faster turn-around on special colors.

EGL's proprietary phosphor coatings dramatically boost adhesion, uniformity, brightness and long term color stability—virtually eliminating flaking, color washout and darkening at bends and splices.

EGL phosphor coatings combine special adhesives, the world's finest phosphors and a range of proprietary additives—specially processed, uniformly coated, baked and annealed in computer controlled ovens at 1000°F (532°C).

Developed and supported by the industry's most renowned phosphor chemists with more than 80 years of combined experience, these formulations deliver unmatched brightness and stability without flaking, washout, ripples, specks or darkening at the bends (even with shades of blue).

And with EGL's Total Quality Management Program, you can count on consistent color and longevity, tube-to-tube, box-to-box, year-to year.



EGL Neon Tubing

All EGL tubing is individually straightened, fire-polished, washed, and dried, using EGL's special Sani-Dry process to eliminate residue contamination. It is then coated, baked, and annealed, reducing glass stress and strain.

The world's finest phosphors, proprietary adhesives, and special additives combine to provide unmatched brilliance and consistency without flaking, even at the tightest bends.



Standard

Signmate™ Single-Coated 4-Foot Neon Tubing



SIGNMATE™ tubing is single-coated with proprietary phosphors to produce the world's most popular whites and colors. All tubing four foot, lead glass.

ITEM NO.	COLOR
NGE8300	8300 Bright White
NGEE65	E65 Daylight (White)
NGEE30	E30 Snowwhite (White)
NGE6500	6500 Snowwhite (White)
NGEOW	Omniwhite
NGEE66	E66 Britewhite (White)
NGE4500	4500 (White)
NGEV4500	V4500 (White)
NGE3500	3500 (White)
NGEV3500	V3500 (White)
NGEE3000	Warm White E3000 (White)
NGEP	H37 Pink
NGEE10	E10 Green
NGEE20	E20 Turquoise
NGEE21	E21 Aqua
NGEE12	E12 Turquoise
NGEE40	E40 Blue

SIZES AVAILABLE:

7, 8, 9, 10, 11, 12, 13, 15 & 18mm

15mm or smaller packed in 25 lb. boxes

18mm packed in 20 lb. boxes.



Signmate II™ Double-Coated 4-Foot Lead Glass



ITEM NO.	COLOR
NGECG	Clear Gold
NGEVP	VP Green
NGECBY	Clear Brite Yellow
NGETY	Tropic Yellow
NGETG	Tropic Green

SIZES AVAILABLE:

10, 11, 12, 13, 15 & 18mm

15mm or smaller packed in 25 lb. boxes

18mm packed in 20 lb. boxes.



SIGNMATE II™ tubing is first coated with a color stain that is baked-on, then with EGL's proprietary phosphors, the pre-staining step resulting in added color vividness and intensity. Available in five select colors, SIGNMATE II tubing is excellent for borders. Care should be used if tight bending patterns are required as bend "washout" may occur.

SIGNMATE AND SIGNMATE II FOOTAGE CHART

Diameter (mm):	8	9	10	11	12	13	15	18
Ft. per Lb. average:	18	16	13	12	11	10	8.5	7.1

HP Series



This High Performance line of neon tubing is a cost effective way to improve your signage and stand out against your competition.

- Higher lumen output
- Increased/superior maintenance
- Non darkening
- Reasonably priced
- Cost effective replacement

ITEM NO.	COLOR
NGEHPNB	HP Neo Blue
NGEHPBL	HP Blue
NGEHPGR	HP Green
NGEHP TU	HP Turquoise

SIZES AVAILABLE:

10, 12, 13, & 15mm

All tubing packed in 25lb. boxes.

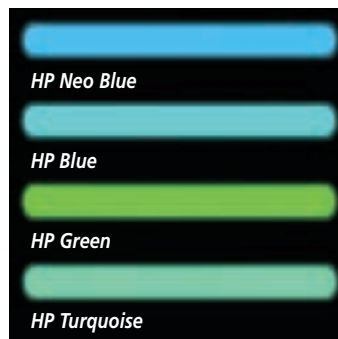

ACCUWALL Machine-Drawn 5-Foot Colored Glass Tubing



ACCUWALL® tubing is the machine-drawn colored glass that's easy to bend, opening a world of design freedom for neon signmakers. It offers a more consistent wall thickness and outside diameter, and more uniform color than traditional colored glass tubing, allowing you to bend and process the sturdiest and most vivid signage attainable in less time, with far less breakage.



ACCUWALL tubing is available uncoated, or coated with EGL's proprietary rare earth phosphors. All have fire-polished ends.

ITEM NO.	COLOR
NGEAQC	Aquamarine (Coated)
NGEBBU	Bromo Blue (Clear)
NGEBBC	Bromo Blue (Coated Blue Glass)
NGEBP	Bromo Blue (Coated Purple)
NGEBRP	Royal Purple (Coated)
NGEEGC	Emerald Green (Coated)
NGENG	Noviol Gold (Clear)
NGEE50	E-50 Noviol Gold (Coated Bright Yellow)
NGEP73	P-73 Noviol Gold (Coated True Gold)
NGES81	S-81 Noviol Gold (Coated Med Yellow)
NGEE60	E-60 Casino Gold (Coated Rich Gold)
NGENG CAG	Apple Green (Coated Noviol Gold Glass)
NGEOC	Orange (Coated)
NGEOCT	Tangerine (Coated Orange Glass)
NGERRU	Ruby Red (Clear)
NGERRC	Ruby Red (Coated)



Where Argon-Mercury is indicated above, Neon is not recommended due to possible inconsistency of color. Specially-formulated phosphors achieve richest colors with Argon Gas Mixture (Blue/K-4)/HG.

SIZES AVAILABLE:

8, 10, 12, & 15mm

All tubing packed in 10 lb. boxes.

ACCUWALL FOOTAGE CHART

Diameter (mm):	8	9	10	12	15
Ft. per Lb. average:	21	19	16	14	10

Neon Tubing Display Briefcase



ITEM NO. NETD

This self-contained, portable sales kit saves time, increases sales, and ensures customer satisfaction with tubing color selections. The lockable slimline briefcase is suited to any business setting, and holds 20 neon tubes, up to four of which can be illuminated simultaneously to demonstrate color combinations.

Standard tubing colors are:

- Bromo Blue Coated Purple
- 8300 White
- 6500 Snowwhite
- Blue
- Horizon Blue
- Bromo Blue Coated
- E-12 Turquoise
- Purple
- Coral Pink
- Violet II
- Flamingo
- Ruby Red Coated
- Clear Brite Yellow
- Clear Gold
- Seacrest
- Green
- Apple Green
- Emerald Green Coated
- Casino Gold
- Royal Purple

All standard tubes are 12mm in diameter and feature EGL electrodes for maximum brilliance, clarity, and longevity.

The unit is equipped with an integral sealed lead acid 12 VDC rechargeable battery with 110/120 VAC charger, measures 16-9/16" x 12-5/8" x 5-1/2", and weighs 12.3 lbs. complete.

Also available custom kits with your choice of colors

Designer

CL Designer® Rare-Earth Colored Tubing

Up to 300% brighter than conventional neon, plus greater output stability and stain resistance.

Using colored C.L. Designer tubing behind colored fascias produces signage that is not only brighter but much more vivid and pure than signage illuminated with conventional white tubing.



ITEM NO.	COLOR
NGECP	Coral Pink
NGEFL	Flamingo
NGEVIII	Violet II
NGEPU	Purple
NGEHB	Horizon Blue
NGESC	Seacrest (Blue Green)

SIZES AVAILABLE:

7, 8, 9, 10, 11, 12, 13, 15 & 18mm

15mm or smaller packed in 25 lb. boxes

18mm packed in 20 lb. boxes.



CL Designer® Rare-Earth White Tubing

C.L. Designer Series® white tubing uses a blend of three rare-earth narrow band phosphors (red, blue and green) to improve color rendition, color preference, and achieve higher output.

ITEM NO.	COLOR
NGECLD24	C.L.Designer 24
NGECLD28	C.L.Designer 28
NGECLD30	C.L.Designer 30
NGECLD35	C.L.Designer 35
NGECLD41	C.L.Designer 41
NGECLD45	C.L.Designer 45
NGECLD65	C.L.Designer 65
NGECLD71	C.L.Designer 71
NGECLD83	C.L.Designer 83

SIZES AVAILABLE:

7, 8, 9, 10, 11, 12, 13, 15 & 18mm

15mm or smaller packed in 25 lb. boxes

18mm packed in 20 lb. boxes.



All tubing four foot, lead glass

Cold Cathode tubing available. For more information please contact your sales rep.

Clear Glass

SIZES AVAILABLE:

5, 6, 7, 8, 9, 10, 11, 12, 13, 15, 18, 20 & 25mm sizes

Packed in 50 lb. boxes

ITEM NO.	LENGTH	SIZE
NGCL5	4'	5mm
NGCL6	4'	6mm
NGCL7	4'	7mm
NGCL8	4'	8mm
NGCL9	4'	9mm
NGCL10	4'	10mm
NGCL11	4'	11mm
NGCL12	4'	12mm
NGCL13	4'	13mm
NGCL15	4'	15mm

ITEM NO.	LENGTH	SIZE
NGCL18	4'	18mm
NGCL20	4'	20mm
NGCL25	4'	25mm
NGCL188	8'	18mm
NGCL208	8'	20mm
NGCL258	8'	25mm

Heavy Wall Glass

ITEM NO.	LENGTH	SIZE
NGCL15HW		15mm



EGL Electrodes

*The World's Largest
Manufacturer of Electrodes!*

EGL Electrodes have consistently raised the industry standards for reliability and performance since their introduction in 1930.

To ensure rigid quality control, all phases of manufacturing are performed in-house, including emission coating, inverter welding shells with lead wires, and sealing and centering the mounts in glass envelopes.

Today EGL manufactures over 75 standard and custom electrodes-- the world's broadest line-- to satisfy your most specialized requirement without compromise.

The latest addition to the growing family of EGL electrodes is the "Advantage™" electrode series, combining the features you need for the ultimate in brilliance, clarity, and longevity.



*For brighter, cleaner, longer lasting neon than ever before possible,
specify advanced Advantage™ electrodes*

Advantage™ Series Electrodes

Heavier gauge, solid nickel, corrosion-proof, seven-strand lead wires

Thicker tubulation wall for easier, stronger tip-offs

100% AMERICAN MADE

After forming, shells receive proprietary nickel plating for more uniform, non-porous coverage

Stronger inner lead wires keep shell centered in tube, reducing vibration

State-of-the-art inverter welding provides superior shell support and conductivity.

Electrodes are fully annealed to relieve stress, preventing cracking

Thicker shell walls heat up evenly, eliminating hot spots, promoting uniform conversion of emission coating

Patented ceramic collar centers shell in tube, eliminating side ignition, sputtering and blackening

Newly developed emission coating measured precisely for each shell, ensuring that all shells "come up" evenly during bombardment

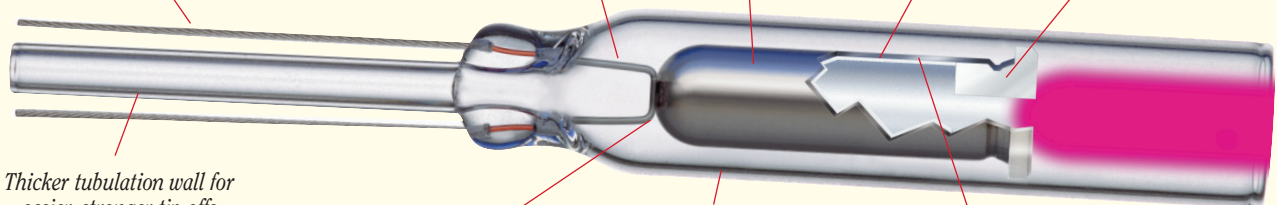

Electrodes

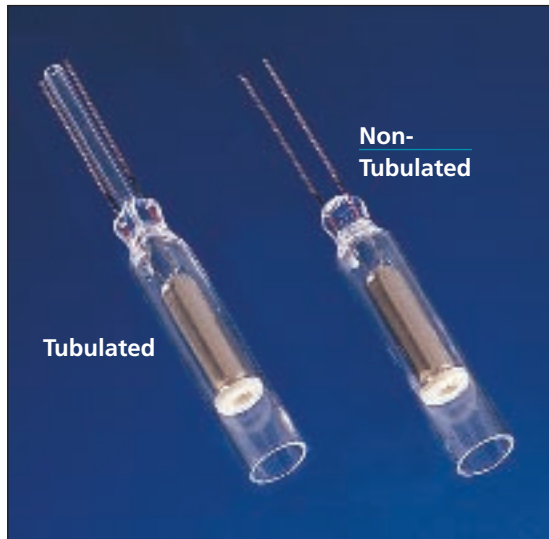

Electrode Application Specification Guide

12CM

Our smallest ceramic collar electrode designed for use 8 - 12mm neon tubing. Neon tubing must not exceed 8 feet and consideration to the electrode size must be exercised during processing. This electrode is rated to operate at 30mA maximum current. Correct processing levels must be monitored with a Milliamp Meter and Torr or Positive Pressure Gauge.

13CL

This electrode is designed for use on 12 – 13mm neon tubing. It is rated for operation on 30 – 45mA transformers and has a longer shell for use on Accuwall classic tubing and units that may require higher current levels during processing. We suggest the use of 9CMC electrodes on smaller diameter units of 8 – 10mm tubing.

15CS

This short (2 inch) electrode was designed for short length 15mm diameter neon units up to 6 feet long. It operates on up to 30mA transformers and is best suited to lead or lead-free glass. The Accuwall classic glass requires electrodes capable of longer processing times. Due to the short length of the shell, the electrode must be carefully monitored to insure it is not overheated during processing. It is ideal in applications where standing electrode height is a factor.

15CM

Our most popular electrode for use in housings or where short returns are used. It is rated for operation on 30 – 45mA transformers and can be used on neon units up to 10 feet long provided processing is monitored with all necessary gauges. Since it has a 500mA processing level, this electrode can also be used on smaller diameters of tubing. We only recommend this electrode be used on a 60mA application under ideal conditions.

15CL

This electrode can be used on all 15mm neon tubes and is rated for use on transformer up to 80mA. It can be ordered in 2 different glass sleeve lengths (2.625 and 2.875 inches). It is not recommended for use on tubing diameters smaller than 15mm due to the high processing current required to fully process the shell. This electrode has successfully outperformed all electrode life tests against our competitors. This shell construction requires full system gauges when processing for best results to insure all recommended levels are achieved and vacuum levels during bombardment are monitored to insure shells are evenly processed.

19CM

This cold cathode electrode operates on 120 – 180mA transformers. It is designed for use on 18 – 25mm cold cathode tubing and must not be used on smaller diameters. It requires a bombarder 15KV or larger to properly heat the shells and glass during production. System requirements and performance must be met before attempting cold cathode production.

19CL

This cold cathode electrode operates on up to 200mA transformers and has a longer shell than the 19CM. Again it requires a larger bombarder, 15KV or larger and system requirements must be met before attempting cold cathode production. Contact EGL for specifications.

ITEM NO.	EGL PART NO.	GLASS		SHELL		MA. RATING
		DIA.	LENGTH	DIA.	LENGTH	
N10S	122100	10mm	2"	¼"	¾"	20-30
NT10S Tubulated	122200	10mm	2"	¼"	¾"	20-30
N12L	119800	12mm	2½"	⅝"	1⅛"	30
NT12L Tubulated	119900	12mm	2½"	⅝"	1⅛"	30
N12CM	119554	12mm	2"	⅝"	¾"	30
NT12CM Tubulated	119654	12mm	2"	⅝"	¾"	30
N12CL	120909	12mm	2½"	⅝"	1⅛"	30-45
NT12CL Tubulated	121009	12mm	2½"	⅝"	1⅛"	30-45
N13CL	120904	13mm	2½"	⅝"	1⅛"	30-45
NT13CL Tubulated	121004	13mm	2½"	⅝"	1⅛"	30-45
N15CS	116004	15mm	2"	⅜"	⅝"	30-45
NT15CS Tubulated	116104	15mm	2"	⅜"	⅝"	30-45
N15CM	117204	15mm	2¾"	⅜"	1"	30-45
NT15CM Tubulated	117304	15mm	2¾"	⅜"	1"	30-45
N15CL258	114805	15mm	2½"	⅜"	1¼"	80
NT15CL258 Tubulated	114905	15mm	2½"	⅜"	1¼"	80
N15CL	115205	15mm	2½"	⅜"	1¼"	80
NT15CL Tubulated	115305	15mm	2½"	⅜"	1¼"	80
N19CM	124500	19mm	2½"	½"	1¼"	120-180
NT19CM Tubulated	124600	19mm	2½"	½"	1¼"	120-180
N19CL	124900	19mm	3½"	½"	1⅝"	200
NT19CL Tubulated	125000	19mm	3½"	½"	1⅝"	200

Housing

PK Housing

- PK Housings provide the best way to penetrate walls for electrode connections.
- Zinc plated steel and borosilicate glass construction
- 1-2-3 spring assembly facilitates easy GTO cable connection (included with PK Housings and also available as a service item.)
- Rated for 7500 volt applications, including 15000 V mid-point referenced transformer installations.
- For UL Wet Rating, PK Housings must be used with PK Silicone Caps placed over the end of PK glass insert to protect from rain, snow, dust and bugs.

PK Plug

Prevent failure of GTO cable at the rear of the PK Housing (abrasion, insect and moisture deterrent) and proposal in UL879 would mandate protection at rear of PK Housing. PK Plug is soft and pliable.



Hex female fitting

1/2" Female hex fitting contains internal threads

Panel hole: 1 3/8", 25 per box

ITEM NO. NPKHF



Reg. Male fitting

1/2" Reg. Male fitting contains external threads.

Panel hole: 1 3/8", 25 per box

ITEM NO. NPKHM

PK Housing Springs

Springs only. 100 per pack.

ITEM NO. NPKHS

Thru-Wall Porcelain Housing

Porcelain, UL Listed
25 per box



Female Threaded Hex End

ITEM NO. NPKHFP

Male Threaded End

ITEM NO. NPKHMP

Front Mounting Plate

- 3" OD for secure, stable mounting of PK housing
- 1.31" Dia ID hole for mounting between PK glass and Housing

25 per pack

ITEM NO. NPKFP



Adjustable Mounting Clamp

- Used to mount PK
- Raises PK to match Two-up, G-cup, or compensate for an odd electrode bend
- Clamps around PK housing with rivet or bolt/nut

25 per box

ITEM NO. NPKAMC



Strain Relief

Strain Reliefs for PK housing
100 per pack

ITEM NO. NPKSR



Porcelain Housing

- Stronger than glass
- Doesn't break like glass
- More drainage holes
- Uniform wall thickness
- Aluminum mounting ring
- No edge glow like glass
- Our phosphor-bronze spring is superior to a stainless steel spring
- Competitive pricing compared to glass

TC-50 (peanut) Porcelain

50 per box

Length: 2 1/2"

Inside Diameter: 7/8"

Outside Diameter : 1 1/4"

ITEM NO. NH200PPC



TC-100 (large) Porcelain

50 per box

Length: 3 3/8"

Inside Diameter: 1 1/8"

Outside Diameter : 1 3/4"

ITEM NO. NH100PC



TC-200 (small) Porcelain Ceramic

50 per box

Length: 3 3/8"

Inside Diameter: 7/8"

Outside Diameter : 1 1/4"

ITEM NO. NH200PC



TC-300 (large) Porcelain

50 per box

Length: 3 3/8"

Inside Diameter: 1 1/8"

Outside Diameter : 1 3/4"

ITEM NO. NH300PC

has a unique window design that offers greater drainage for water and insect accumulation



1019 (porcelain)

50 per box

Length: 2 1/4"

Inside Diameter: 1 3/16"

Outside Diameter : 1 1/4"

ITEM NO. NH300PPC



Housing

Glass Housing

- Affordable and safe method for making neon electrode connections in raceways
- Suitable for indoor, outdoor protected, and outdoor exposed (wet) locations
- Borosilicate heat resistant glass
- Spring contact allows for easy neon tube servicing
- Rated for 7500 volt applications, including 15,000 V mid-point referenced transformer installations
- Comes with a plated steel ferrule to secure the unit to the sign enclosure
- #300 and #300P Recommended for use with new UL 2161 Listed transformers to minimize nuisance tripping

#100 Glass Housing

50 per box
Panel hole: 1 $\frac{3}{4}$ "
Housing opening: 1 $\frac{1}{4}$ "
Overall height: 3 $\frac{5}{8}$ "

ITEM NO. NH100



#200 Glass Housing

50 per box
Panel hole: 1 $\frac{3}{8}$ "
Housing opening: 7/8"
Overall height: 3 $\frac{1}{2}$ "

ITEM NO. NH200



#200P Glass Housing

100 per box
Panel hole: 1 $\frac{3}{8}$ "
Housing opening: 7/8"
Overall height: 2 $\frac{1}{2}$ "

ITEM NO. NH200P



#300 Glass Housing

100 per box
Panel hole: 1 $\frac{1}{2}$ "
Housing opening: 1 $\frac{1}{4}$ "
Overall height: 3 $\frac{1}{2}$ "

ITEM NO. NH300



#300P Glass Housing

100 per box
Panel hole: 1 $\frac{1}{2}$ "
Housing opening: 1 $\frac{1}{4}$ "
Overall height: 3 $\frac{1}{2}$ "

ITEM NO. NH300P

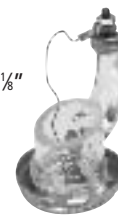

#20 Glass Bushing

- Borosilicate heat resistant glass
- Comes with a plated steel ferrule to secure the unit to the sign enclosure
- Enables a neon electrode to penetrate safely into a sign enclosure.

25 per box
Hole: 1 $\frac{1}{8}$ "
Opening: 7/8"
Height: 2 $\frac{1}{2}$ "



Slip-Stick Bushing

Heavy wall glass insulator with one-way clip and rubber.
Length: 4 $\frac{1}{4}$ "
25 per box

ITEM NO. NSS



G-2 Neon Electrode Receptacle

Use for connecting two neon electrodes; simply attach electrode buttons and insert into receptacle. Includes zinc coated steel base and one piece compression spring electrode connector. Complies with UL 2161 20.1 Exception No. 3 and also with 1999 NEC 600-23(b) Exception No. 2. Use with SGFP-exempt PBKM transformers in self-contained letters.

Metal base can be inverted and recessed for use with 1 $\frac{3}{4}$ " tube supports for a slim, neat appearance.

50 per box

ITEM NO. NHG2C



Need help selecting the right product?

Need help selecting the best product to meet your neon sign project? What's the best glass, transformer, etc. for your application? Or, should you use LED modules for this project? Wondering about warranties and specs? Our "neonology" experts will be happy to provide you with clear, concise answers – just ask!



Housing Accessories

PK Silicone Cap

- A flexible silicone rubber cap to protect from rain, snow, dust and bugs.
- Fits A#200, #200P Glass Housings and PK™ Housings
- Improves UL Listing of Westrim PK™ Housings to wet locations which includes outdoor exposed installations

100 per pack

ITEM NO. NPKRC

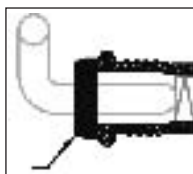

Housing Cap – Plastic Igloo Style

- Provides effective installation for the GTO connection to the housing
- UL listed for dry and damp at 7500 volts max, including 15,000 V mid-point referenced transformer installations
- Fits #100, #200 and #200P Glass Housings or any 8-32 housing stud
- Rigid plastic, igloo-shaped

100 per pack

ITEM NO. NHC

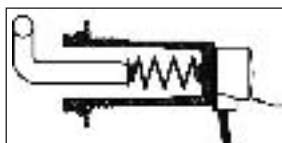

Neon Electrode Housing Boots

- Eliminate potential arcing problems and fire hazards
- prevent contamination of high-voltage connections
- The only multi-purpose housing cap available

WPB-100-EGH

Fits #100 Glass Electrode Housing

*Will Accommodate
12mm, 15mm & 18mm neon tubes*

ITEM NO. NHB100

WPB-200-EGH

Fits #200 Glass Electrode Housing

*Will Accommodate
10mm, 12mm & 15mm neon tubes*

ITEM NO. NHB200

WPB-303-EMH Universal Cap

Fits all Metal Cased Neon Electrode Housings

*Will Accommodate
12mm, 15mm & 18mm neon tubes*

ITEM NO. NPKHB



Brass Electrode Caps

- Use on tubulated electrodes to protect the tubulation from damage
- Use with any housing which utilizes a spring-type electrode contact
- Made of brass to provide a positive electrical connection and resist corrosion
- Available in 12 and 15 mm diameters, regular and long lengths



ITEM #	DESCRIPTION	DIMENSIONS DxL
NEC12	12mm regular	.45" x .615"
NEC12(L)	12mm long	.45" x .87"
NEC15	15mm regular	.575" x .615"
NEC15(L)	15mm long	.575" x .87"
NEC19(L)	19mm long	

Brass Electrode Buttons

Electrode buttons are most commonly used to provide positive high voltage connection for electrodes inserted in spring type housings of similar receptacles. Designed for use with 12mm - 15mm electrodes.

- Use on non-tabulated electrodes
- Use with any housing which utilizes a spring-type electrode contact
- Made with wings to secure electrode wires

1000 per pack



ITEM #	DESCRIPTION	DIMENSIONS DxL
NEB15	15mm	.72 x .016"

1-2-3 Spring Assembly

- Stainless steel spring, rivet and brass washer assembly
- Included with all Westrim PK™ Housings
- Facilitates easy GTO cable connections
- Packaged in bags of 25 each-complete with installation instructions

ITEM NO. NPK123



Electrode Saver

Used for servicing broken electrodes.

Size: 15mm

ITEM NO. NES15



Wiring & Connecting

Electrode Insulator Boot

- Prevents Contamination of high voltage connections, Arcing problems & Fire hazards.
- Eliminates Drilling 1-1/2" holes, Revamping neon units, Labor on installations, Additional cost of housing, Expensive return service calls
- Boots are UL and CSA listed for dry, damp, or wet locations.



One-Piece Electrode Insulator Boot

Neon electrode insulator boot may be used on straight neon tubing or double-back applications.

ITEM NO.	SIZE	COLOR
NMEIB110BK	10mm	Black
NMEIB115BK	15mm	Black

Two-Piece Water-Tite Electrode Insulator Boot

Neon electrode insulator boot used on double-back applications.

ITEM NO.	SIZE	COLOR
NMEIB212BK	12mm	Black
NMEIB215BK	15mm	Black

Electrode Housing Wide

For dry and damp locations only

Used to insulate the connection between electrode and GTO cable inside raceway-mounted channel letters with any sign face material where 90° angle installations are necessary. Designed to fit inside glass housings and hold in place around glass ends. Internal ring makes the housing weather-tight.

- Made of flame retardant PYROLENE105.
- 50 per bag



ElectroBits

ITEM NO.	SIZE	COLOR
NEBEHW3BLK	13mm	Black
NEBEHW3WHT	13mm	White
NEBEHW5BLK	15mm	Black
NEBEHW5WHT	15mm	White

Electrode Housing Sleeve Wide

For dry and damp locations only

Used to insulate the connection between electrode and GTO cable inside raceway-mounted channel letters with any sign face material where 90° angle installations are necessary. Designed to fit inside glass housings and hold in place around glass ends. Internal ring makes the housing weather-tight. With attached GTOSLEEVEING 3730.

- Made of flame retardant PYROLENE105.
- 50 per bag

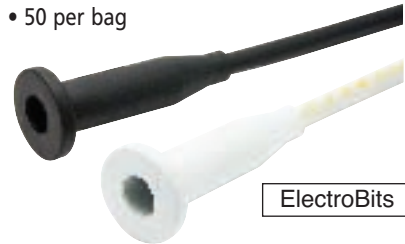

ElectroBits

ITEM NO.	SIZE	COLOR
NEBEHSW3BLK	13mm	Black
NEBEHSW3WHT	13mm	White
NEBEHSW5BLK	15mm	Black
NEBEHSW5WHT	15mm	White

Short Stops

Used to insulate connections between electrodes and GTO cables. Easy to slide onto electrodes without breaking glass.

100 per pack.

Also available in master box of 1680 pcs.



ITEM NO.	SIZE	COLOR
NASS10BK	10mm	Black
NASS10GY	10mm	Gray
NASS13BK	13mm	Black
NASS13GY	13mm	Gray
NASS15BK	15mm	Black
NASS15GY	15mm	Gray

End Caps

Used to insulate connections between electrodes and high voltage cables. Easy to slide onto electrodes without breaking glass.

100 per pack.

Also available in master box of 1680 pcs.



ITEM NO.	SIZE	COLOR
NAEC10BK	10mm	Black
NAEC10GY	10mm	Gray
NAEC12/13BK	12/13mm	Black
NAEC12/13WHT	12/13mm	White
NAEC12/13GY	12/13mm	Gray
NAEC15BK	15mm	Black
NAEC15WHT	15mm	White
NAEC15GY	15mm	Gray

End Cap

ElectroBits

For dry and damp locations

Use to insulate double back connections between electrodes and GTO

100 per bag.



ITEM NO.	SIZE	COLOR
NEBEC13BK	12/13mm	Black
NEBEC13WHT	12/13mm	White
NEBEC15BK	15mm	Black
NEBEC15WHT	15mm	White

Short Stop

ElectroBits

For dry and damp locations

Use to insulate straight aligned connections between electrodes and GTO cable.

100 per bag.



ITEM NO.	SIZE	COLOR
NEBSS13BK	13mm	Black
NEBSS15BK	15mm	Black
NEBSS15WHT	15mm	White

End Cap Residential

For dry and damp locations only

Insulate electrode connections for residential use. Complete with lock system.

100 per bag



ElectroBits

ITEM NO.	SIZE	COLOR
NEBECR10WBLK	10mm	Black
NEBECR10WWHT	10mm	White
NEBECR13WBLK	13mm	Black
NEBECR13WWHT	13mm	White
NEBECR15WBLK	15mm	Black
NEBECR15WWHT	15mm	White
NEBECR16WBLK	16mm	Black
NEBECR16WWHT	16mm	White

Low Voltage End Cap

For dry and damp locations only

Insulate electrode connections for low voltage signs.

100 per bag



ElectroBits

ITEM NO.	SIZE	COLOR
NEBEC10TBLK	10mm	Black
NEBEC10TWHT	10mm	White
NEBEC13TBLK	13mm	Black
NEBEC13TWHT	13mm	White
NEBEC15TBLK	15mm	Black
NEBEC15TWHT	15mm	White

Long Sleeve

For dry and damp locations only

Used to insulate connections between electrodes placed within 1 to 3 inches away from each other. May be secured in place with two wraps of electrical tape

- 100 per bag

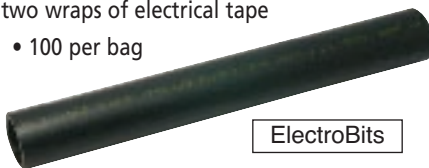

ElectroBits

ITEM NO.	SIZE	COLOR
NEBLS13BK	13mm	Black
NEBLS13WHT	13mm	White
NEBLS15BK	15mm	Black
NEBLS15WHT	15mm	White



Your Complete Source for

LARGE FORMAT

Printers & Media

Billboards...



Fleet Graphics



Trade Show Signage



Visit the S&F
Digital Graphics Showroom

Wiring & Connecting

GTO Cable

GTO-15 Silicone Integral Sleeved

Silicone integral sleeve GTO is UL814 approved and is rated 15000V at 150C. It uses 14 AWG tinned copper conductor and is insulated with flexible 100% pure silicone and 200C Dielectric silicone. GTO wire is resistant to humidity, UV, Ozone and Corona.



ITEM NO.	COLOR	ROLL LENGTH
NGTOFW	White	150'
NGTOFBK	Black	150'

NOODLE FLEX

ITEM NO.	COLOR	ROLL LENGTH
NGTOBK1500	BLACK	14ga 1000'
NGTOBK14	BLACK	14ga 250'



GTOFullflex

w/GTO Sleeving 3730 or wGTO Covering 3870

The GTOFullflex series reduces installation time with pre-sleeved GTOFlex GTO15 wire.

- Pre-sleeved GTOFlex GTO15 18 AWG, 19 strand copper wire in: GTO Sleeving 3730 for use with ECW and SSW series, or GTO Covering 3870 for maximum reduction of capacitive loading and corona buildup.
- 100 Foot rolls

ITEM #	DESCRIPTION	COLOR
NEBFFGTOBK	GTO15,18G,3730	Black
NEBFFGTOWHT	GTO15,18G,3730	White



ElectroBits

GTO Sleeving 3730 & 3830

For dry and damp locations

100 Foot rolls

#3730

Use to protect and cover GTO cable when using wide end caps and wide short sleeves.

#3830

Use to protect and cover GTO cable when using non-wide end caps and non-wide short sleeves.

ElectroBits



ITEM #	INTERIOR DIA.	EXTERIOR DIA.	COLOR
NEB3730BK	7.7mm	9.2mm	Black
NEB3730WHT	7.7mm	9.2mm	White
NEB3830BK	9.6mm	11mm	Black
NEB3830WHT	9.6mm	11mm	White

GTO Covering 3870

For dry and damp locations

100 Foot rolls

Use to protect and cover GTO cable where extra insulation and/or physical protection is desired.

ITEM #	DIAMENSIONS	COLOR
NEB3870BK	2mm wall thickness	Black
NEB3870WHT	2mm wall thickness	White



Non-Metallic Greenfield

ID PVC sleeving for GTO and primary wire, designed to be used with the Quik-Connect, and 101-F and 101-G connectors, UL Recognized. 100' roll per box

Available in 3/8" or 1/2"

ITEM NO. NHNMG38

ITEM NO. NHNMG12



GTO Clear Vinyl Covering

100' (3/8"x5/8")

ITEM NO. NGTOCCO



PLASTIC TUBE

1" O.D. x 72" (3/4" ID)

ITEM NO. PLT172

Wiring & Connecting

Cable Supports

- Use to provide wire standoff distances in accordance with the NEC
- Made from electrical grade porcelain
- Available with mounting screw for metal or wood (please specify)
- Overall Height 2 1/2"
- Diameter: 1 1/4"



ITEM NO.	DESCRIPTION
NPCSM	with mounting screw for metal
NPCSW	with mounting screw for wood

Ring Terminals

- Use to connect GTO to transformer terminals or to housings
- Wire size: 14-16 awg
- Wire strip length: 1/4" (6.5mm)
- No flammable plastic on crimp end to cause fires



ITEM#	EYELET SIZE	QUANTITY
ESNC	0.265" (#12 - 1/4" stud)	200
ESNI	0.200" (#8 - #10" stud)	250

Connectors

High Voltage Connector

One piece die cast zinc housing with mounting bracket, ground screw, one-screw duplex clamp and one piece insulator cap made of flame retardant PYROLENE105.

HVC 1001 insulates splice between two GTO cables. When routed through listed sign enclosures, GTO cables should be covered with GtoSleeving or GtoCovering. When routed outside listed sign enclosures, GTO cables should be covered with GtoSleeving and routed through flexible or rigid metallic conduit. Use with 1/2" conduit. 10 per pack

ITEM NO. NEBHVC1001



High Voltage Junction Box

Channel letters are fully assembled in the shop with the electrode receptacles installed, tubes mounted, wired complete with flex conduit and GTO. At the installation site, the letters are mounted to the building and wired to one another using the hi-volt connector. This procedure reduces glass breakage.

- Splices two GTO cables.
- Rated for 7500 volt applications, including 15000V mid-point referenced transformer installations
- Electrical grade porcelain and zinc plated steel construction
- 1/2" conduit knock-outs (one on each side and two on the bottom)

25 per box

ITEM NO. NPHVC



High Voltage Connector

Insulates GTO wire splice. For use with 1/2 inch liquid-tight flexible metallic conduit, or non-metallic electrical.

10 per pack

ITEM NO. NPOWERBOX



Neon Dimmers

Neon Dimmers are designed to control the brightness of neon tubing. They have special triax components to withstand burnout from the coils of neon transformers which destroy regular incandescent dimmers. Come in 4 models.

5 AMP Hard Wire Dimmer

- 600 VA, 5.2 Amps
- Strapmount
- Push-On/Off
- Field adjustable trim
- UL listed

ITEM NO. NDNE5



5 AMP Plug-In Dimmer

- 600 VA, 5.2 Amps
- Rotary Switch, also dims
- Incandescent signs
- UL listed

ITEM NO. NDNE5P



10 AMP Hard Wire Dimmer

- 1,000 VA, 8.4 Amps
- Single gang faceplate
- Field adjustable trim
- UL listed

ITEM NO. NDNE10



15 AMP Hard Wire Dimmer

- 1,500 VA, 12.5 Amps
- Double gang faceplate
- Field adjustable trim
- UL listed

ITEM NO. NDNE15



Wiring & Connecting

Passthru™ (PT) Wiring Assembly Conduit Kit

For use only with neon transformer or power supply secondary circuit high voltage wiring

The Passthru is used to protect the passage of GTO cables through walls, ceilings, raceways, channel letters and sign enclosures. Use pre-cut pt's for known installation requirements. Use field-cut pt-kits to cut unknown lengths on site. Use Passthru with grounding ring (PTGR) to comply with CSA requirements.

- Threaded half-inch aluminum conduit kit. Each pre-cut passthru comes with four locknuts, two plastic bushings, one sealing bushing. Pt1 comes with two locknuts, two plastic bushing and one sealing bushing.
- For dry and damp locations only

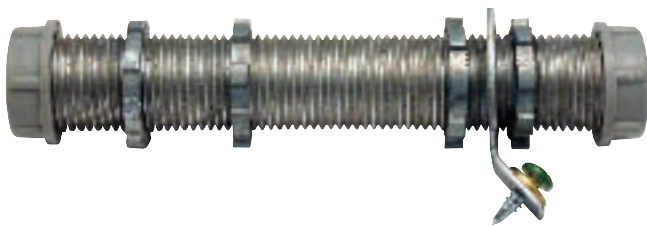

Passthru

ITEM NO.	LENGTH	PACKAGE
NEBPT1	1"	50
NEBPT2	2"	25
NEBPT3	3"	10
NEBPT4	4"	10
NEBPT5	5"	10
NEBPT6	6"	10
NEBPT7	7"	10
NEBPT8	8"	10
NEBPT10	10"	10
NEBPT12	12"	10
NEBPT16	16"	10
NEBPT18	18"	10
NEBPT20	20"	10
NEBPT24	24"	10

Passthru w/Grounding Ring

ITEM NO.	LENGTH	PACKAGE
NEBPTGR1	1"	50
NEBPTGR2	2"	25
NEBPTGR3	3"	10
NEBPTGR4	4"	10
NEBPTGR5	5"	10
NEBPTGR6	6"	10
NEBPTGR7	7"	10
NEBPTGR8	8"	10
NEBPTGR10	10"	10
NEBPTGR12	12"	10
NEBPTGR16	16"	10
NEBPTGR18	18"	10
NEBPTGR20	20"	10
NEBPTGR24	24"	10

For outdoor applications, install SRPT sealing ring, where the conduit enters the sign housing, to prevent water from entering the back of the sign.

PT-kit

Comes with:

- 5 length of 24" passthru conduit
- 60 locknuts
- 30 plastic bushings
- 15 sealing bushings

Pt-kits can make up to 15 PT's. Additional components can be purchased separately to make a greater number of shorter PT's.

ITEM NO. NEBPTKIT

Locknut

Provides a mechanical bond to sign enclosure for a passthru. Also provides a mechanical bond for a ground ring.

100 per pack

ITEM NO. NEBLNUT



Ground Ring

Provides a ground bonding point for a passthru.

50 per pack

ITEM NO. NEBRNGR



Plastic Bushing

Provides insulation and mechanical protection for GTO cables at the entrance and exits of a passthru.

100 per pack

ITEM NO. NEBPB12



Sealing Bushing

Provides a moisture seal at the exterior entrance to a passthru.

100 per pack

ITEM NO. NEBSBPT



Sealing Ring

Provides a moisture seal to prevent water from entering through the back of a sign enclosure where a passthru enters.

50 per pack

ITEM NO. NEBSRPT



Strain Relief

Thermo plastic strain relief.

This non-metallic connector is used to fasten 3870 or 3730 covered GTO wire to a 1/2 inch transformer enclosure knockout. 25 per pack.

ITEM NO. NEBSR12

ITEM NO. NEBSR38



Straight Connector Female

Used to twist-on fasten 3/8 or 1/2 inch flexible metallic conduit to a passthru conduit. Made of die-cast zinc with female 1/2 inch NPT threads to screw onto passthru conduit. 25 per pack.

ITEM NO. NEBSCF12

to connect 1/2" flexible metallic conduit

ITEM NO. NEBSCF38

to connect 3/8" flexible metallic conduit



Straight Connector Male

Used to twist-on fasten 3/8" or 1/2" flexible metallic conduit to a transformer 1/2" knockout. Made of die-cast zinc with male 1/2" npt thread and locknut to fasten to a transformer closure.

25 per pack

ITEM NO. NEBSC12

to connect 1/2" flexible metallic conduit

ITEM NO. NEBSC38

to connect 3/8" flexible metallic conduit



90° Connector Female

Used to twist-on fasten 1/2" flexible metallic conduit to a passthru conduit where installation distance is limited. Made of die-cast zinc with female 1/2" npt threads to screw onto passthru with a 90° connection. 25 per pack.

ITEM NO. NEB90CF12



C.P.A. Conduit Plug Assembly

Thru-wall assembly for neon double-back electrodes in wet, damp or dry locations. Patented silicone grommet seals against weather. Can be used outdoors unprotected when used with G Cup mounted with closed end at least 45° above horizontal.

25 per box

ITEM NO. NCPA



Quik-Connect

- For channel letter installations
- Insulates high voltage GTO cable from going to ground
- Protects against corona and ozone that deteriorates insulation
- Provides smooth wall to protect insulated wire where passing through metal panels or enclosures
- UL Listed in the US for interior applications
- Smaller outside diameter to reduce larger drill bit size
- Color: blockout black

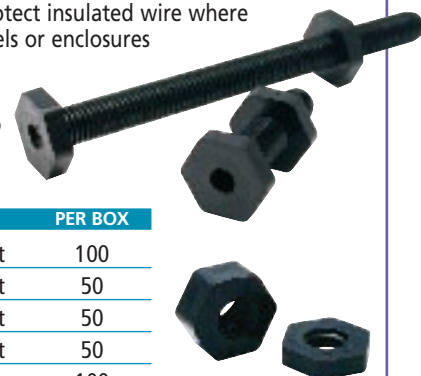

ITEM NO.	DESCRIPTION	PER BOX
NDQC2	2" Quik-Connect	100
NDQC4	4" Quik-Connect	50
NDQC6	6" Quik-Connect	50
NDQC8	8" Quik-Connect	50
ND12SP	1/2" Spacer	100
ND14N	1/4" Locknut	100

Greenfield Open Connector

Has an ID thread on one end that threads onto the Quik-Connect and a nipple on the opposite end that threads into the 3/8" Non-Metallic Greenfield.

100 per box

ITEM NO. NDGFC



Greenfield Closed Connector

Has a nipple on one end that threads into the 3/8" Non-Metallic Greenfield and an OD thread with a locknut on the opposite end that inserts into knockouts in metal panels and enclosures.

100 per box

ITEM NO. NDCLGF



Heyco Bushing

7/8" O.D. x 3/8" I.D.

ITEM NO. NHB78X38

7/8" O.D. x 3/4" I.D.

ITEM NO. NHB78X34



Non-Metallic Greenfield

ID PVC sleeving for GTO and primary wire, designed to be used with the Quik-Connect, and 101-F and 101-G connectors, UL Recognized.

Quantity: 100' roll per box

Available in 3/8" or 1/2"

ITEM NO. NHNMG38

ITEM NO. NHNMG12



Tube Support



FMS/McMahan Tube Supports

One Piece Base Supports

Our most economical tube support, the Model 52 features a one piece base. The threaded glass stand is 10mm in diameter and measures 1 1/4 inches from center of saddle to end of stem. UL and cUL listed.

For installations that benefit from increased glass height such as deep channel letters, the Model 500 provides 5-1/4" of clearance from the mounting surface. UL listed.

Both models available with brass or aluminum base, with or without tie-wires.



ITEM NO.	DESCRIPTION	BASE	HEIGHT	PACK
NTS52	Tube Support	Aluminum	1 1/4"	500
NTS52TW	Tube Support w/Tie Wires	Aluminum	1 1/4"	500
NTS52B	Tube Support	Brass	1 1/4"	500
NTS52BTW	Tube Support w/Tie Wires	Brass	1 1/4"	500
NTS500A	Tube Support	Aluminum	5 1/4"	100
NTS500ATW	Tube Support w/Tie Wires	Aluminum	5 1/4"	100
NTS500B	Tube Support	Brass	5 1/4"	100
NTS500BTW	Tube Support w/Tie Wires	Brass	5 1/4"	100

Economical One Piece Base Supports

Both models available with brass or aluminum base, with or without tie-wires.



ITEM NO.	DESCRIPTION	BASE	HEIGHT	PACK
NTSEC52A	Tube Support	Aluminum	1 1/4"	500
NTSEC52ATW	Tube Support w/Tie Wires	Aluminum	1 1/4"	500
NTSEC52B	Tube Support	Brass	1 1/4"	500
NTSEC52BTW	Tube Support w/Tie Wires	Brass	1 1/4"	500

Two Piece Spring Temper Brass Base Supports

Our exclusive two piece spring temper brass base features two locking notches which hold the glass more securely than conventional one piece bases. This support available in 8mm and 10mm diameter threaded glass stand which is 1 1/4 inches from center of saddle to end of stem.



A longer version of the 10mm is available that provides 2 1/2" of clearance to help accommodate new code requirements.

The Model 835 tube support is designed for applications where more space is desired or necessary between the fluorescent tube and the sign face. The glass stand is 3 1/2 inches long with cut-off notches every quarter inch starting at 2 inches. The 835 features a two piece zinc plated spring temper brass base. In addition to their standard size, Model 835 tube supports are also stocked at a length of 2 1/2 inches. UL and cUL listed.

ITEM NO.	DESCRIPTION	GLASS DIA.	BASE HEIGHT	PACK
NTS10T3	Tube Support	10mm	Brass 1 1/4"	500
NTS10T3TW	Tube Support w/Tie Wires	10mm	Brass 1 1/4"	500
NTS10T3L	Tube Support	10mm	Brass 2 1/2"	500
NTS10T3LTW	Tube Support w/Tie Wires	10mm	Brass 2 1/2"	500
NTS8T	Tube Support	8mm	Brass 2 1/2"	500
NTS8TTW	Tube Support w/Tie Wires	8mm	Brass 2 1/2"	500
NTS835	Tube Support		Brass 3 1/2"	100
NTS835TW	Tube Support w/Tie Wires		Brass 3 1/2"	100

Coil Spring Base Supports

Our Model 30 tube support features a coil spring base made from zinc plated spring temper brass wire. The glass stand twists into the spring coil easily, but will not pull out when tube is attached.

The Model 30 is particularly effective when used on fluorescent tubing which is installed and then subject to vibration in shipping, high winds, or other similar conditions. The Model 30 also features a threaded glass stand 10mm in diameter and 1 1/4 inches from center of saddle to end of stem. UL and cUL listed.

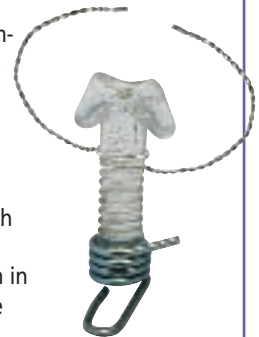

ITEM NO.	DESCRIPTION	BASE	HEIGHT	PACK
NTS30	Tube Support	Brass	1 1/4"	500
NTS30TW	Tube Support w/Tie Wires	Brass	1 1/4"	500

Tube Support

Tube Supports

Pro-V Clear Tube Support

- Fits tubing 10 to 16 mm
- 2-Piece UV Resistant Clear Polycarbonate Construction
- Clip rotates full 360 degrees for easy installation
- Length adjustable from 1 5/8" to 2"
- 100 per bag, 10 bags per box



ITEM NO. NPPCTS

Grab-It Tube Support

ITEM NO.	FOR TUBE SIZE
NTSGI8	8
NTSGI9	9
NTSGI10	10
NTSGI12	12
NTSGI13	13
NTSGI15	15



Quick Support

ITEM NO.		PACK
NDQS1	QS-1	100
NDQS5	QS-5	500



Aluminum Extension Post

ITEM NO. NEP



Clear Vue Tube Support

- Virtually invisible in use
- Mounts through center
- Clear Polycarbonate material
 - UV Stabilized
 - V-0 Flame Rating



ITEM NO.	HEIGHT
NTSCV10	3/8"
NTSCV20	3/4"
NTSCV30	1 1/16"
NTSCV40	1 1/8"
NTSCV50	2"
NTSCV60	2 3/8"
NTSCV70	2 3/4"

Copper Tie Wire

- 22 AWG solid, bare copper
- Use in securing neon tubing to tube supports
- Available in 1 lb, and 5 lb reels
- Approximately 500 feet per pound



ITEM #	DESCRIPTION
NCW1	Tie wire, 1 lb. spool
NCW5	Tie wire, 5 lb. spool

Thinned Coating Silver Tie Wire

ITEM #	DESCRIPTION
NCW51	1 lb. spool



Stainless Steel Tie Wire

ITEM #	DESCRIPTION
PCTW20	.020, 1lb. spool
PCTW30	.032, 1lb. spool



Stazon Blockout Paint & Thinner



Stazon blockout paint is generally used on fluorescent sign tubing where portions of the tubing are to be "blocked out" and thus not show as being illuminated.

- Quick drying
- Dries to a sharp edge
- Resists blistering and cracking
- Apply with brush or dip
- Heat resistant
- Waterproof
- Re-dissolvable

Available in Black, Light Gray and White.

Stazon Blockout Paint now also comes in an environmentally-friendly water-based formula. With the opacity, adherence, coverage, and ease-of-use you'd expect from the makers of the world's favorite solvent-based blockout paint.

Solvent-Based

ITEM NO.	COLOR	SIZE
NBOBKQ	Black	Quart
NBOBKG	Black	Gallon
NBOLGQ	Lt. Gray	Quart
NBOLGG	Lt. Gray	Gallon
NBOWQ	White	Quart
NBOWG	White	Gallon
NBOTQ	Thinner	Quart
NBOTG	Thinner	Gallon

Water-Based

ITEM NO.	COLOR	SIZE
NBOWBBKQ	Black	Quart
NBOWBBKG	Black	Gallon
NBOWBGYQ	Gray	Quart
NBOWBGYG	Gray	Gallon

Blockout Brush



ITEM NO.	DESCRIPTION
NBB12	1/2" Brush
NBB1	1" Brush



www.sfsupplies.com



INDEX

DIGITAL MEDIA	5
SIGN VINYL	45
VINYL AND WRAP SUPPLIES	59
WIDE FORMAT EQUIPMENT	73
VINYL CUTTERS	87
ENGRAVERS	95
SOFTWARE	97
SUBSTRATES	105
BANNER	127
SIGN DISPLAY	139
TAPES & ADHESIVES	145
PAINT	153
NEON SUPPLIES & EQUIPMENT	167
TRANSFORMERS	207

FERROMAGNETIC

Outdoor	208-210
Self-Enclosed	211-212
Indoor	213-214
Housing Style	215-216
Cold Cathode	217
Testers	217
Accessories	218
Cross Reference Chart	219-221
ANSI Luminous Tube Footage Chart ...	222-223

ELECTRONIC

Indoor	224-225
Channer Letter	226-227
12 VDC Power Supply	228

LED SYSTEMS	229
LIGHTING & ELECTRIC	243
SIGN EXTRUSION	267
LETTER & ACCESSORIES	277
MOUNTING HARDWARE	281
EQUIPMENT & SHOP TOOLS	293

Outdoor

Standard Outdoor Style Protector™ Normal Power Factor 30mA/60mA

- Secondary circuit ground fault protection, interrupting transformer output to eliminate the danger of a fire in case of an arc to ground.
- LED diagnostics, reduces troubleshooting time.
- A 29-minute by-pass switch, which enables efficient fault detection, in the same manner that you were accustomed to work with old UL506 transformers.
- Three automatic resets, eliminating nuisance tripping, providing continuous and better performance, thus saving service costs.
- Available in 277 and 347V, which results in potential cost savings, as you can install more transformers per circuit when compared to 120V applications.



CASE A BPX Style



CASE B CPX Style

Transformers are UL2161
Listed and CSA Approved.

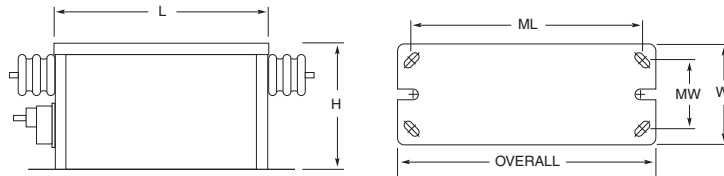

Normal Power Factor 120/277 Volts, 60 Hertz

120 Volts				277 Volts				DIMENSIONS IN INCHES							CASE	WT. LBS.
ITEM NO.	LINE AMP	ITEM NO.	LINE AMP	SECONDARY KV	PRIMARY MA	PRIMARY VA	OVERALL	L	W	H	ML	MW				
NA 1530BPX 120	3.75	NA 1530BPX 277	1.62	15,000	30	450	11	9	4 3/8	5 3/8	10	2 1/2	A	22		
NA 1230BPX 120	3.00	NA 1230BPX 277	1.30	12,000	30	360	11	9	4 3/8	5 3/8	10	2 1/2	A	22		
NA 930CPX 120	2.25	NA 930CPX 277	0.97	9,000	30	270	9 1/2	8 1/4	3 3/8	3 3/8	8 3/8	2	B	13		
NA 7530CPX 120	1.88	NA 7530CPX 277	0.81	7,500	30	225	9 1/2	8 1/4	3 3/8	3 3/8	8 3/8	2	B	13		
NA 630C 120	1.50	NA 630C 277	0.65	6,000	30	180	9 1/2	8 1/4	3 3/8	3 3/8	8 3/8	2	B	13		
NA 530C 120	1.33	NA 530C 277	0.58	5,000	30	160	9 1/2	8 1/4	3 3/8	3 3/8	8 3/8	2	B	13		
NA 430C 120	1.17	NA 430C 277	0.51	4,000	30	140	9 1/2	8 1/4	3 3/8	3 3/8	8 3/8	2	B	13		
NA 330C 120	0.83	NA 330C 277	0.36	3,000	30	100	9 1/2	8 1/4	3 3/8	3 3/8	8 3/8	2	B	13		
NA 1560BPX 120	7.50	NA 1560BPX 277	3.25	15,000	60	900	11 1/8	9 1/2	5 3/8	6 1/2	10 3/8	2 1/2	A	36		
NA 1260BPX 120	6.00	NA 1260BPX 277	2.60	12,000	60	720	11 1/8	9 1/2	5 3/8	6 1/2	10 3/8	2 1/2	A	35		
NA 960BPX 120	4.50	NA 960BPX 277	1.95	9,000	60	540	11	9	4 3/8	5 3/8	10	2 1/2	A	22		
NA 7560BPX 120	3.75	NA 7560BPX 277	1.62	7,500	60	450	11	9	4 3/8	5 3/8	10	2 1/2	A	22		
NA 660BPX 120	3.00	NA 660BPX 277	1.30	6,000	60	360	11	9	4 3/8	5 3/8	10	2 1/2	A	22		
NA 560CPX 120	2.66	NA 560CPX 277	1.15	5,000	60	320	9 1/2	8 1/4	3 3/8	3 3/8	8 3/8	2	B	13		
NA 460CPX 120	2.40	NA 460CPX 277	1.04	4,000	60	290	9 1/2	8 1/4	3 3/8	3 3/8	8 3/8	2	B	13		
NA 360CPX 120	2.00	NA 360CPX 277	0.87	3,000	60	240	9 1/2	8 1/4	3 3/8	3 3/8	8 3/8	2	B	13		

Aeon™ Outdoor Transformer 2-15/30mA

One power-sensing Aeon™ transformer replaces ten fixed voltage units; reducing the number of SKUs to be inventoried and transported to installation sites and service calls by 90%. Aeon™ part# 21530BPX120 will replace 15, 12, 10.5, 9, 7.5, 6, 5, 4, 3, and 2 thousand Volt units.



120 Volts		SECONDARY			PRIMARY	DIMENSIONS IN INCHES						CASE	WT. LBS.
ITEM NO.	AMP	KV	MA	VA	OVERALL	L	W	H	ML	MW			
NA 21530BPX 120	2.50	2000-15,000	30	300	11 1/4	9	6 3/8	4 3/8	10 1/4	2 1/2	A	22	

Standard Outdoor Style Protector™ High Power Factor

- Secondary circuit ground fault protection, interrupting transformer output to eliminate the danger of a fire in case of an arc to ground.
- LED diagnostics, reduces troubleshooting time.
- A 29-minute by-pass switch, which enables efficient fault detection, in the same manner that you were accustomed to work with old UL506 transformers.
- Three automatic resets, eliminating nuisance tripping, providing continuous and better performance, thus saving service costs.
- Available in 277 and 347V, which results in potential cost savings, as you can install more transformers per circuit when compared to 120V applications.



CASE A BPX Style



CASE B CPX Style

Transformers are UL2161 Listed and CSA Approved.

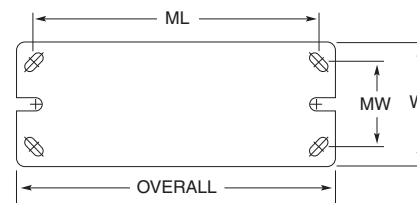
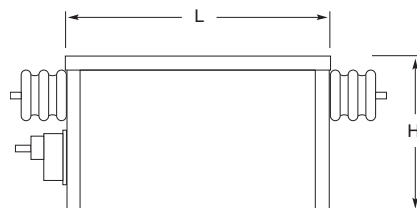

High Power Factor 120 Volts, 60 Hertz

120 Volts		277 Volts		DIMENSIONS IN INCHES										CASE	WT. LBS.
ITEM NO.	LINE AMP	ITEM NO.	LINE AMP	SECONDARY KV	PRIMARY MA	VA	OVERALL	L	W	H	ML	MW			
NA P1530BPX 120	2.08	NA P1530BPX 277	0.90	15,000	30	250	11¼	9	4¾	6¾	10¼	2½	A	23	
NA P1230BPX 120	1.67	NA P1230BPX 277	0.72	12,000	30	200	11¼	9	4¾	6¾	10¼	2½	A	23	
NA P1030BPX 120	1.46	NA P1030BPX 277	0.63	10,500	30	170	11¼	9	4¾	6¾	10¼	2½	A	23	
NA P930CPX 120	1.25	NA P930CPX 277	0.54	9,000	30	150	11¼	10	3½	3¾	10¾	2	B	15	
NA P7530CPX 120	1.04	NA P7530CPX 277	0.45	7,500	30	125	11¼	10	3½	3¾	10¾	2	B	15	
NA P630C 120	0.83	NA P630C 277	0.36	6,000	30	100	11¼	10	3½	3¾	10¾	2	B	15	
NA P530C 120	0.75	NA P530C 277	0.32	5,000	30	90	11¼	10	3½	3¾	10¾	2	B	15	
NA P430C 120	0.62	NA P430C 277	0.27	4,000	30	75	11¼	10	3½	3¾	10¾	2	B	15	
NA P330C 120	0.46	NA P330C 277	0.20	3,000	30	55	11¼	10	3½	3¾	10¾	2	B	15	
NA P1560BPX 120	4.17	NA P1560BPX 277	1.81	15,000	60	500	11¾	9½	5½	6½	10¾	2½	A	36	
NA P1260BPX 120	3.33	NA P1260BPX 277	1.44	12,000	60	400	11¾	9½	5½	6½	10¾	2½	A	35	
NA P960BPX 120	2.50	NA P960BPX 277	1.08	9,000	60	300	11¼	9	4¾	6¾	10¼	2½	A	23	
NA P7560BPX 120	2.08	NA P7560BPX 277	0.90	7,500	60	250	11¼	9	4¾	6¾	10¼	2½	A	23	
NA P660BPX 120	1.67	NA P660BPX 277	0.72	6,000	60	200	11¼	9	4¾	6¾	10¼	2½	A	23	
NA P560CPX 120	1.42	NA P560CPX 277	0.62	5,000	60	170	11¼	10	3½	3¾	10¾	2	B	15	
NA P460CPX 120	1.09	NA P460CPX 277	0.47	4,000	60	130	11¼	10	3½	3¾	10¾	2	B	15	
NA P360CPX 120	0.85	NA P360CPX 277	0.36	3,000	60	100	11¼	10	3½	3¾	10¾	2	B	15	

Outdoor

Standard Outdoor Style Protector™ Normal Power Factor 30mA/60mA

FRANCE

- **Primary Wiring Requirements of a Standard Transformer** - with the added safety of Secondary Ground Fault Protection.
- **Bypass Feature** - For easy troubleshooting of ground faults and primary wiring problems. Overrides the SCGFP for up to 30 minutes.
- **Diagnostic Circuits** - LED indicates the reason for service, allowing for quick, easy troubleshooting.
- **User Friendly** - Adapts to any grounding situation.
- **Secondary Circuit Ground Fault Protection** - (SCGFP) Disables unit upon detection of arcs to ground in compliance with UL2161 and NEC requirements.
- **Can be used in flashing/dimming applications.**



Transformers are UL2161 Listed and CSA Approved.

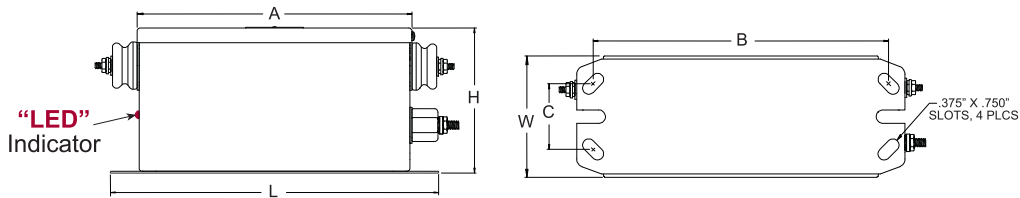

Normal Power Factor 120 Volts, 60 Hertz

120 Volts			DIMENSIONS IN INCHES										WT. LBS.
ITEM NO.	MFR. PART NO.	AMP	SECONDARY		PRIMARY	L	W	H	A	B	C		
			KV	MA	VA								
NF15300	15030P5G-2E	3.60	15,000	30	435	11.25	4.656	5.205	9.203	10.125	3.0	21	
NF12300	12030P5G-2E	3.15	12,000	30	380	11.25	4.656	5.205	9.203	10.125	3.0	18	
NF9300	9030P5G-2E	2.35	9,000	30	285	10.0	3.7	4.89	8.375	9.0	2.0	13	
NF75600	7560P5G-2E	3.85	7,500	60	460	11.25	4.656	5.205	9.203	10.125	3.0	21	

Unitran™ Protector™ Self-Enclosed Style



- Recommended for indoor neon signs and indoor neon lighting.
- Outdoor non-weatherproof unitran enclosed design, providing pre-wiring for easy installation, eliminating the need for a transformer box and primary switch.
- Secondary circuit ground fault protection, interrupting transformer output to eliminate the danger of a fire in case of an arc to ground.
- Three automatic resets, eliminates nuisance tripping, provides continuous and better performance, thus saving service costs.
- A 29-minute by-pass switch, which enables efficient fault detection, in the same manner that you were accustomed to work with the old UL506 transformers.
- High power factor, 277 and 347 Volt models, which allows installation of more units on one circuit, saving material and labour costs.

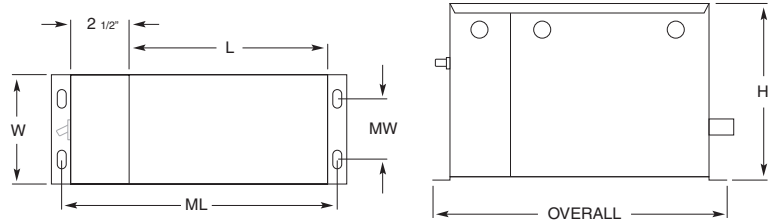

Transformers are UL2161 Listed and CSA Approved.



Normal Power Factor 120/277 Volts, 60 Hertz

120 Volts		277 Volts		SECONDARY		PRIMARY	DIMENSIONS IN INCHES					WT.	
ITEM NO.	LINE AMP	ITEM NO.	LINE AMP	KV	MA	VA	OVERALL	L	W	H	ML	MW	LBS.
NA 1530FPX 120	3.75	NA 1530FPX 277	1.62	15,000	30	450	12½	10¾	4½	7⅞	11¾	2½	23
NA 1230FPX 120	3.00	NA 1230FPX 277	1.30	12,000	30	360	12½	10¾	4½	7⅞	11¾	2½	23
NA 1030FPX 120	2.62	NA 1030FPX 277	1.14	10,500	30	315	12½	10¾	4½	7⅞	11¾	2½	23
NA 930FPX 120	2.25	NA 930FPX 277	0.97	9,000	30	270	12½	10¾	4½	7⅞	11¾	2½	15
NA 7530FPX 120	1.88	NA 7530FPX 277	0.81	7,500	30	225	12½	10¾	4½	7⅞	11¾	2½	15
NA 630F 120	1.58	NA 630F 277	0.69	6,000	30	180	12½	10¾	4½	7⅞	11¾	2½	13
NA 530F 120	1.33	NA 530F 277	0.58	5,000	30	160	12½	10¾	4½	7⅞	11¾	2½	13
NA 430F 120	1.17	NA 430F 277	0.51	4,000	30	140	12½	10¾	4½	7⅞	11¾	2½	13
NA 330F 120	0.83	NA 330F 277	0.36	3,000	30	100	12½	10¾	4½	7⅞	11¾	2½	13
NA 1560FPX 120	7.50	NA 1560FPX 277	3.25	15,000	60	900	13¾	11½	5⅞	8¼	12½	2½	37
NA 1260FPX 120	6.00	NA 1260FPX 277	2.60	12,000	60	720	13¾	11½	5⅞	8¼	12½	2½	37
NA 960FPX 120	4.50	NA 960FPX 277	1.95	9,000	60	540	12½	10¾	4½	7⅞	11¾	2½	23
NA 7560FPX 120	3.75	NA 7560FPX 277	1.62	7,500	60	450	12½	10¾	4½	7⅞	11¾	2½	23
NA 660FPX 120	3.00	NA 660FPX 277	1.38	6,000	60	360	12½	10¾	4½	7⅞	11¾	2½	23
NA 560FPX 120	2.66	NA 560FPX 277	1.15	5,000	60	320	12½	10¾	4½	7⅞	11¾	2½	23
NA 460FPX 120	2.40	NA 460FPX 277	1.04	4,000	60	280	12½	10¾	4½	7⅞	11¾	2½	23
NA 360FPX 120	2.00	NA 360FPX 277	0.87	3,000	60	240	12½	10¾	4½	7⅞	11¾	2½	23

High Power Factor models

Available in all sizes. Use same item no. as normal power factor, add "P" after "NA" [i.e. NA1530FPX would be NAP1530FPX.

Self-Enclosed

Self-Enclosed Style

FRANCE

- **Diagnostic Circuit** - LED indicates the reason for service, allowing for quick, easy troubleshooting
- **Primary Wiring Requirements of a Non-SCGFP** - with the added safety of Secondary Ground Fault Protection.
- **Service Switch** - For easy troubleshooting of ground faults and primary wiring problems. Overrides the SCGFP for up to 30 minutes.
- **Auto Reset** - After secondary ground fault, automatically attempts to reset three times within ten seconds. Manual reset possible at any time by disconnecting primary power.
- **Can be used in flashing/dimming applications.**
- **Secondary Circuit Ground Fault Protection** - (SCGFP) Disables unit upon detection of arcs to ground in compliance with UL2161 and NEC requirements.
- **Easy Wiring Methods** - Virtual Ground and Series Wiring Methods
- **User Friendly** - Adapts to most grounding situations.
- **Easy to carry handle.**
- **On/Off Toggle Switch.**

Transformers are UL2161 Listed and CSA Approved.

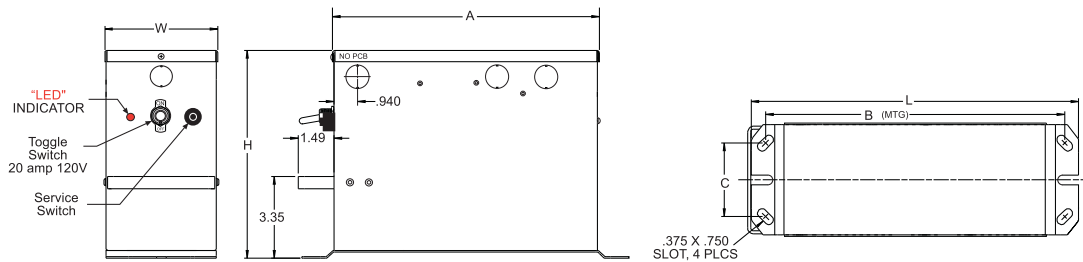

Normal Power Factor 277 Volts, 60 Hertz

120 Volts		AMP	SECONDARY		PRIMARY VA	DIMENSIONS IN INCHES						WT. LBS.
ITEM NO.	MFR. PART NO.		KV	MA		L	W	H	A	B	C	
NF1530EN277	15030 P5KA2NG-2E	1.55	15,000	30	425	13.35	4.50	5.205	9.203	10.125	3.0	25
NF930EN277	9030 P5KA2NG-2E	1.00	9,000	30	275	13.35	4.50	5.205	9.203	10.125	3.0	19

Indoor Hanger Type

- **Hanging bracket**, enabling easier installation and dual mounting methods in indoor applications.
- **Secondary circuit ground fault protection**, interrupting transformer output to eliminate the danger of a fire in case of an arc to ground.
- **Supplied with cord and plug, primary switch and secondary GTO leads**, saving wiring costs during installation of your neon signs.
- **Sleeveless GTO # 16 AWG 15 kV**, eliminates the need for additional sleeving, thus minimizes losses while operating the electrical sign.



CASE A 12kv & 15kv

CASE B 7.5kv & 9kv

Transformers are UL2161 Listed and CSA Approved.



CASE A

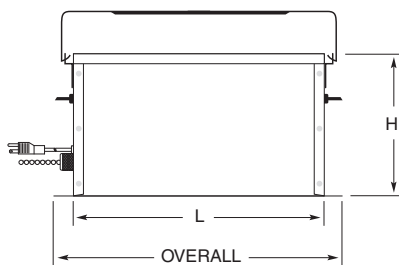

CASE B

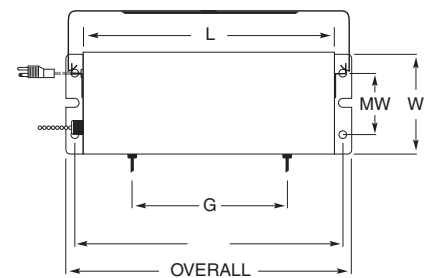

Normal Power Factor 120 Volts, 60 Hertz

120 Volts		SECONDARY		PRIMARY	DIMENSIONS IN INCHES							CASE	WT. LBS.
ITEM NO.	AMP	KV	MA	VA	OVERALL	L	W	H	ML	MW	G		
NA 1530HP 120	3.90	15,000	30	470	11¼	9	6¾	4¾	10¼	2½	9	A	22
NA 1230HP 120	3.00	12,000	30	360	11¼	9	6¾	4¾	10¼	2½	9	A	22
NA 930HP 120	2.50	9,000	30	295	9½	8¼	3¾	3¾	8¾	2	4½	B	13
NA 7530HP 120	2.05	7,500	30	245	9½	8¼	3¾	3¾	8¾	2	4½	B	13

Indoor

Indoor Hanger Type

FRANCE

- Brackets Are Provided for Easy Wall or Ceiling Installation
- 8' Ft. Three-Conductor Line Cord with 3-Prong Plug, Pull-Chain ON/OFF Switch, and 24" Long Secondary Cable
- Secondary Circuit Ground Fault Protection



Transformers are UL2161 Listed and CSA Approved.

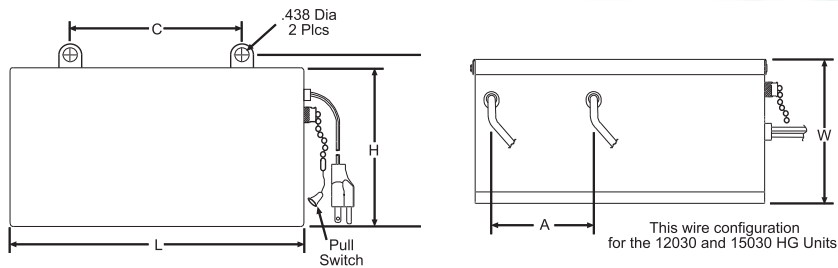

Normal Power Factor 120 Volts, 60 Hertz

120 Volts		AMP	SECONDARY		PRIMARY VA	DIMENSIONS IN INCHES						WT. LBS.
ITEM NO.	MFR. PART NO.		KV	MA		L	W	H	A	B	C	
NF1530H	15030HG	1.55	15,000	30	425	13.35	4.50	5.205	9.203	10.125	3.0	25
NF1230H	12030HG	1.00	12,000	30	275	13.35	4.50	5.205	9.203	10.125	3.0	19
NF930H	9030HG	1.00	9,000	30	275	13.35	4.50	5.205	9.203	10.125	3.0	19

Housing /Mini Housing Style

- **No secondary wiring required**, resulting in safer, more efficient installation of your neon sign.
- **Deep electrode housings**, providing greater overall protection, longevity and better fit for your electrodes.
- **High power factor models are available**, which allows installation of more units on one circuit, saving material and labour costs.
- **Available in 277 and 347V**, which results in potential cost savings, as you can install more transformers per circuit when compared to 120V applications.



Transformers are UL2161 Listed and CSA Approved.

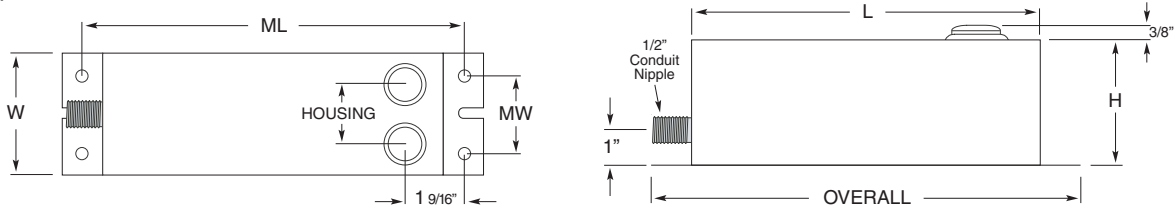

Normal Power Factor 120/277 Volts-60 Hertz

120 Volts				277 Volts				DIMENSIONS IN INCHES							WT. LBS.
ITEM NO.	LINE AMP	ITEM NO.	LINE AMP	SECONDARY KV	MA	PRIMARY VA	OVERALL	L	W	H	ML	MW	HOUSING		
NA 1230EK 120	3.00	NA 1230EK 277	1.30	12,000	30	360	11 1/8	10 3/8	4 1/2	4 1/8	11	2	2 1/2	23	
NA 1030EK 120	2.62	NA 1030EK 277	1.14	10,500	30	315	11 1/8	10 3/8	4 1/2	4 1/8	11	2	2 1/2	23	
NA 930EK 120	2.25	NA 930EK 277	0.97	9,000	30	270	11	9 3/8	3 3/8	3 3/8	10 1/4	2	1 3/4	13	
NA 7530EK 120	1.88	NA 7530EK 277	0.81	7,500	30	225	11	9 3/8	3 3/8	3 3/8	10 1/4	2	1 3/4	13	
NA 630EK 120	1.58	NA 630EK 277	0.69	6,000	30	180	11	9 3/8	3 3/8	3 3/8	10 1/4	2	1 3/4	13	
NA 530EK 120	1.33	NA 530EK 277	0.58	5,000	30	160	8 3/8	7	3 3/8	3 3/8	7 3/8	2	1 3/4	10	
NA 430EK 120	1.17	NA 430EK 277	0.51	4,000	30	140	8 3/8	7	3 3/8	3 3/8	7 3/8	2	1 3/4	10	
NA 330EK 120	0.83	NA 330EK 277	0.36	3,000	30	100	8 3/8	7	3 3/8	3 3/8	7 3/8	2	1 3/4	10	
NA 1260EK 120	6.00	NA 1260EK 277	2.60	12,000	60	720	13 3/8	11 3/4	5 1/2	4 3/4	12 1/2	2 1/2	2 1/2	35	
NA 960EK 120	4.50	NA 960EK 277	1.95	9,000	60	540	15	13 3/8	3 3/8	3 3/8	14 1/4	2	1 3/4	22	
NA 7560EK 120	3.75	NA 7560EK 277	1.62	7,500	60	450	15	13 3/8	3 3/8	3 3/8	14 1/4	2	1 3/4	22	
NA 660EK 120	3.00	NA 660EK 277	1.38	6,000	60	360	11 3/4	10 3/8	3 3/8	3 3/8	11	2	1 3/4	22	
NA 560EK 120	2.66	NA 560EK 277	1.15	5,000	60	320	11 3/4	10 3/8	3 3/8	3 3/8	11	2	1 3/4	13	
NA 460EK 120	2.40	NA 460EK 277	1.04	4,000	60	290	11	9 3/8	3 3/8	3 3/8	10 1/4	2	1 3/4	13	
NA 360EK 120	2.00	NA 360EK 277	0.87	3,000	60	240	11	9 3/8	3 3/8	3 3/8	10 1/4	2	1 3/4	13	

High Power Factor models

Available in all sizes. Use same item no. as normal power factor, add "P" after "NA" [i.e. NA1530FPX would be NAP1530FPX.

Mini-Housing

120 Volts		SECONDARY				DIMENSIONS IN INCHES							WT. LBS.
ITEM NO.	AMP	KV	MA	PRIMARY VA	OVERALL	L	W	H	ML	MW	HOUSING		
NA MINI 530EK 120	1.33	5,000	30	160	6 1/16	5 13/16	3 3/16	2 7/8	6 5/16	2	1 1/2	6.5	
NA MINI 430EK 120	1.17	4,000	30	140	6 1/16	5 13/16	3 3/16	2 7/8	6 5/16	2	1 1/2	6.5	
NA MINI 330EK 120	0.83	3,000	30	100	6 1/16	5 13/16	3 3/16	2 7/8	6 5/16	2	1 1/2	6.5	

Housing Style

Self Contained Housing Style



- No secondary wiring, resulting in safer, more efficient installation.
- Pre-stripped wires, which allows faster installation.
- Integral junction box neatly encloses primary wiring, saving installation cost of additional junction box.
- Four knockouts are provided, allowing access to wiring from 4 different directions, which results in easier installation and less labour costs.
- High power factor models are available, which allows installation of more units on one circuit, saving material and labour costs.
- Available in 277 and 347V, which results in potential cost savings, as you can install more transformers per circuit when compared to 120V applications.



Transformers are UL2161 Listed and CSA Approved.

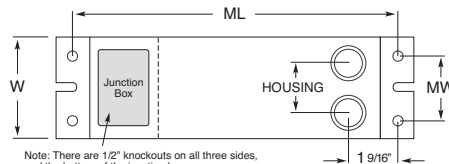

Note: There are 1/2" knockouts on all three sides, and the bottom of the junction box. Hot, neutral, and ground leads are pre-stripped and tinned.

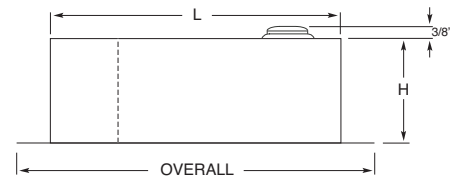

Normal Power Factor 120/277 Volts-60 Hertz

120 Volts				277 Volts				DIMENSIONS IN INCHES							WT. LBS.
ITEM NO.	LINE AMP	ITEM NO.	LINE AMP	SECONDARY KV	MA	PRIMARY VA	OVERALL	L	W	H	ML	MW	HOUSING		
NA 930EKF 120	2.25	NA 930EKF 277	0.97	9,000	30	270	13 3/8	12	3 3/8	3 3/8	12 3/8	2	1 3/8	14	
NA 7530EKF 120	1.88	NA 7530EKF 277	0.81	7,500	30	225	13 3/8	12	3 3/8	3 3/8	12 3/8	2	1 3/8	14	
NA 630EKF 120	1.58	NA 630EKF 277	0.69	6,000	30	180	13 3/8	12	3 3/8	3 3/8	12 3/8	2	1 3/8	14	
NA 530EKF 120	1.33	NA 530EKF 277	0.58	5,000	30	160	13 3/8	12	3 3/8	3 3/8	12 3/8	2	1 3/8	14	
NA 430EKF 120	1.17	NA 430EKF 277	0.51	4,000	30	140	13 3/8	12	3 3/8	3 3/8	12 3/8	2	1 3/8	14	
NA 330EKF 120	0.83	NA 330EKF 277	0.36	3,000	30	100	13 3/8	12	3 3/8	3 3/8	12 3/8	2	1 3/8	14	
NA 960EKF 120	4.50	NA 960EKF 277	1.95	9,000	60	540	17 3/8	16	3 3/8	3 3/8	16 3/8	2	1 3/8	22	
NA 7560EKF 120	3.75	NA 7560EKF 277	1.62	7,500	60	450	17 3/8	16	3 3/8	3 3/8	16 3/8	2	1 3/8	22	
NA 660EKF 120	3.00	NA 660EKF 277	1.38	6,000	60	360	13 3/8	12	3 3/8	3 3/8	12 3/8	2	1 3/8	14	
NA 560EKF 120	2.66	NA 560EKF 277	1.15	5,000	60	320	13 3/8	12	3 3/8	3 3/8	12 3/8	2	1 3/8	14	
NA 460EKF 120	2.40	NA 460EKF 277	1.04	4,000	60	290	13 3/8	12	3 3/8	3 3/8	12 3/8	2	1 3/8	14	
NA 360EKF 120	2.00	NA 360EKF 277	0.87	3,000	60	240	13 3/8	12	3 3/8	3 3/8	12 3/8	2	1 3/8	14	

High Power Factor 120/277 Volts-60 Hertz

120 Volts				277 Volts				DIMENSIONS IN INCHES							WT. LBS.
ITEM NO.	LINE AMP	ITEM NO.	LINE AMP	SECONDARY KV	MA	PRIMARY VA	OVERALL	L	W	H	ML	MW	HOUSING		
NA P930EKF 120	1.25	NA P930EKF 277	0.54	9,000	30	150	15 3/8	14	3 3/8	3 3/8	14 3/8	2	1 3/8	14	
NA P7530EKF 120	1.04	NA P7530EKF 277	0.45	7,500	30	125	15 3/8	14	3 3/8	3 3/8	14 3/8	2	1 3/8	14	
NA P630EKF 120	0.83	NA P630EKF 277	0.36	6,000	30	100	15 3/8	14	3 3/8	3 3/8	14 3/8	2	1 3/8	14	
NA P530EKF 120	0.75	NA P530EKF 277	0.32	5,000	30	90	13 3/8	12	3 3/8	3 3/8	12 3/8	2	1 3/8	14	
NA P430EKF 120	0.62	NA P430EKF 277	0.27	4,000	30	75	13 3/8	12	3 3/8	3 3/8	12 3/8	2	1 3/8	14	
NA P330EKF 120	0.46	NA P330EKF 277	0.20	3,000	30	55	13 3/8	12	3 3/8	3 3/8	12 3/8	2	1 3/8	14	
NA P960EKF 120	2.50	NA P960EKF 277	1.08	9,000	60	300	19 3/8	18	3 3/8	3 3/8	18 3/8	2	1 3/8	23	
NA P7560EKF 120	2.08	NA P7560EKF 277	0.90	7,500	60	250	19 3/8	18	3 3/8	3 3/8	18 3/8	2	1 3/8	23	
NA P660EKF 120	1.67	NA P660EKF 277	0.72	6,000	60	200	15 3/8	14	3 3/8	3 3/8	14 3/8	2	1 3/8	14	
NA P560EKF 120	1.42	NA P560EKF 277	0.62	5,000	60	170	15 3/8	14	3 3/8	3 3/8	14 3/8	2	1 3/8	14	
NA P460EKF 120	1.09	NA P460EKF 277	0.47	4,000	60	130	15 3/8	14	3 3/8	3 3/8	14 3/8	2	1 3/8	14	
NA P360EKF 120	0.84	NA P360EKF 277	0.36	3,000	60	100	15 3/8	14	3 3/8	3 3/8	14 3/8	2	1 3/8	14	

Cold Cathode / Testers

Cold Cathode Transformers

- Mid-point grounded and balanced design, providing safer operation of your neon sign.
- High power factor models are available, which allows installation of more units on one circuit, saving material and labour costs.
- Low temperature rise, providing lower operating temperature, reducing the probability of heat problems and extending longevity of the installation.



Transformers are UL2161 Listed and CSA Approved.



Cold Cathode Housings

Cold Cathode Housings are rated @ 7500V to ground. Milled out of stock material, not from a mold. wire strip gauge is imprinted on unit. Can be recessed or externally mounted. Stainless steel mounting screw for GTO or Ballast wire.



Features solid brass receptacles for electrodes. User friendly (wiring and mounting abilities.)

RK212SJ (Jumper)

ITEM NO. NGECCHRK212SJ

RK212ST (Terminal)

ITEM NO. NGECCHRK212ST

Digital Clamp-on Multimeter

The DL235 True RMS Clamp-On takes the mystery out of electrical diagnostics. Identify harmonics with the SOFT/CREST features or simultaneously monitor current and frequency. High scales and broad bandwidth give you the ability to tame today's tough electrical problems.

ITEM NO. NAHVMM



High Voltage Probe

Measures loaded or unloaded neon transformers. Use in combination with multimeter.

- # MAX. Voltage : DC : 40KV, AC : 28KV, (50/60Hz only) CAT II.
- 1000MΩ Input Impedance.

ITEM NO. NAHVP



Electronic Milliamp Meter

The digital mA meter was designed to measure true RMS current on core and coil and electronic transformers when placed in a series connection of multiple tubes. It is compact, convenient, requires no batteries, has a frequency range of 50 to 50,000hz, and can measure from 3 to 200mA/AC. The meter readings should be taken with the meter placed in series in the neon circuit, ideally at mid-point.

ITEM NO. 645300



Neon Transformer Selektor

Accurately displays your neon transformer load requirement. This unit can be used with any combination neon tube diameters and fills for loads of 2,000-15,000 Volts

ITEM NO. NTS



Receptacle Tester

- Tests for open grounds, open hots, open neutrals and reversed polarity
- Compact unit simply plugs into any standard 3-wire/grounded receptacle
- 110-125V AC

ITEM NO. EPT



High Voltage Testing

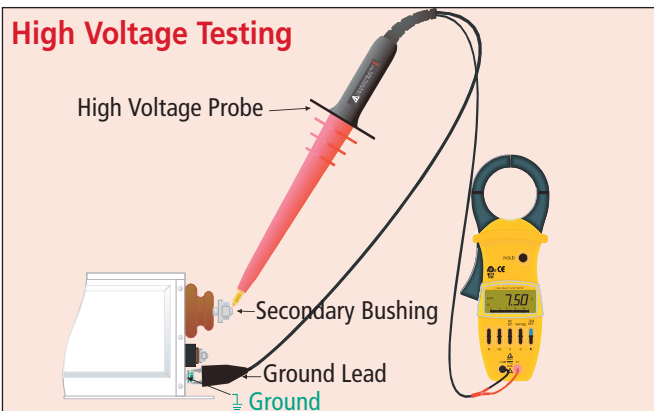

Accessories

Transformer Cans

Top-Off Transformer Can

UL Listed for EXPOSED (WET) locations

- Includes 10-16 washer head self-piercing screws to prevent water leaks
- Listed to applicable U.S. and Canadian standards and requirements for outdoor exposed (wet) locations by Underwriters Laboratories, Inc.
- Strong and rigid; made of G90 galvanized steel sheet .029 inch thick
- Convenient 1/2" conduit knockouts – 6 on each end
- Knockouts for toggle switch – 2 on each end
- Exceeds requirements of the 1999 NEC, Article 600-8

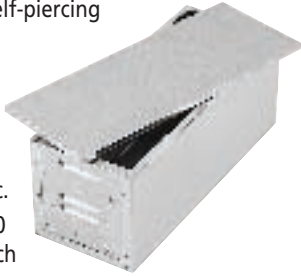

ITEM NO.	SIZE (LxWxH)	WIEGHT
NTB	18" x 7" x 7"	74 lbs/dozen

Top /Top & Side-Off Transformer Can

UL Listed for protected (damp) locations

- UL Listed for US and Canada
- Strong and rigid; made of G90 galvanized steel sheet .029 inch thick
- Convenient 1/2" conduit knockouts – 6 on each end
- Knockouts for toggle switch – 2 on each end
- Multiple louvers on each end to maximize ventilation and extend transformer life
- Exceeds requirements of the 1999 NEC, Article 600-8

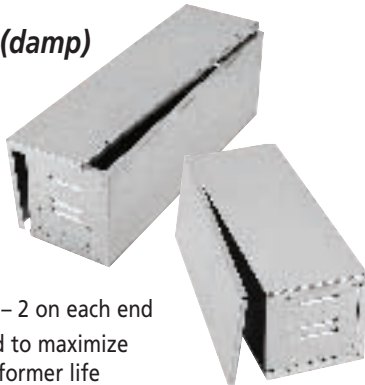

Side-Off Transformer Can

ITEM NO.	SIZE (LxWxH)	WIEGHT
TC18SO-UL	18" x 7" x 7"	74 lbs/dozen

Top & Side-Off Transformer Can

ITEM NO.	SIZE (LxWxH)	WIEGHT
TC24TSO-UL	24" x 7" x 8"	8 lb
TC36TSO-UL	34½" x 7" x 8"	11 lb

Cold Cathode Transformer Can

UL Listed for EXPOSED (WET) locations

- Installed 10-16 washer head screws prevent water leaks
- Listed to applicable U.S. and Canadian standards and requirements for outdoor exposed (wet) locations by Underwriters Laboratories, Inc.
- Strong and rigid; made of G90 galvanized steel sheet .029 inch thick
- Convenient 1/2" conduit knockouts – 2 on each end
- Knockouts for toggle switch – 2 on each end
- Exceeds requirements of the 1999 NEC, Article 600-8

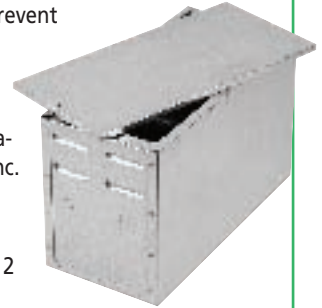

ITEM NO.	SIZE (LxWxH)	WIEGHT
TC14CC-UL	20" x 9" x 12"	10

E-Z UP Mounting Bracket

- Designed to provide the UL required 1/2" spacing below transformer to avoid moisture problems
- .047" thick steel easily supports over 200 lbs each!
- Better heat transfer and greater stability than "double nutting"
- Universal slots fit all transformers without drilling
- Galvanized steel to simplify bonding requirements
- Packed in boxes of 50

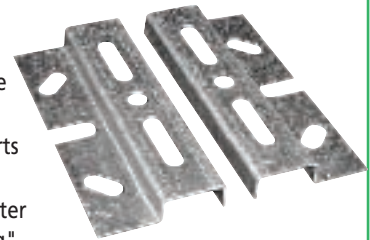

ITEM NO. NTBMB

Federal Bushings – 1/2" Porcelain

- Use to pass GTO cable through raceway barriers
- Made from electrical grade porcelain
- 1/2" conduit threads with locknut
- Pre-assembled
- Thread depth: 11/16" (8 threads)



100 per pack

ITEM NO. NFB

Heyco Bushing

7/8" O.D. x 3/8" I.D.

ITEM NO. NHB78X38

7/8" O.D x 3/4" I.D.

ITEM NO. NHB78X34



Cross Reference Chart

Cross Reference for UL-2161 Outdoor Style, Normal Power Factor

	Allanson	Lecip	France	Magnetek	Transco	Actown
30 mA 120V						
15kV, 30mA	1530BPX 120	4B15N3-CB	15030 P5G-2	M15030GF120N-T	T1512G	1530-OG
12kV, 30mA	1230BPX 120	4B12N3-CB	12030 P5G-2	M12030GF120N-T	T1212G	1230-OG
10.5kV, 30mA	1030BPX 120	N/A	10530 P5G-2	N/A	N/A	N/A
9kV, 30mA	930CPX 120	4B09N3-CB	9030 P5G-2	M9030GF120N-T	T912G	9030-OG
7.5kV, 30mA	7530CPX 120	4B75N3-CB	7530 P5G-2	M75030GF120N-T	T7512G	7530-OG
6kV, 30mA	630C 120		6030-PG1	M6030G120N-C	T612	6030-O
5kV, 30mA	530C 120		5030-PG1	M5030G120N-C	T512	5030-O
4kV, 30mA	430C 120		4030-PG1	M4030GF120N-C	T412	4030-O
3kV, 30mA	330C 120		N/A	M3030G120N-C	T312	3030-O
60 mA 120V						
15kV, 60mA	1560BPX 120	4B15N6-CB	15060 P5G-2	M15060GF120N-T	S1512G	1560-OG
12kV, 60mA	1260BPX 120	4B12N6-CB	12060 P5G-2	M12060GF120N-T	S1212G	1260-OG
9kV, 60mA	960BPX 120	4B09N6-CB	9060 P5G-2	M9060GF120N-T	S912G	9060-OG
7.5kV, 60mA	7560BPX 120	4B75N6-CB	7560 P5G-2	M75060GF120N-T	S7512G	7560-OG
6kV, 60mA	660BPX 120		6060 P5G-2	N/A	S612G	6060-OG
5kV, 60mA	560CPX 120		5060 P5G-2	N/A	S512G	5060-OG
4kV, 60mA	460CPX 120		4060 P5G-2	N/A	S412G	4060-OG
3kV, 60mA	360CPX 120		N/A	N/A	N/A	3060-OG
30 mA 277V						
15kV, 30mA	1530BPX 277	7B15N3-CB	15030 P5G-2 277	M15030GF277N-T	T1527G	1530-OG277
12kV, 30mA	1230BPX 277	7B12N3-CB	12030 P5G-2 277	M12030GF277N-T	T1227G	1230-OG277
10.5kV, 30mA	1030BPX 277		10530 P5G-2 277	N/A	N/A	N/A
9kV, 30mA	930CPX 277	7B09N3-CB	9030 P5G-2 277	M9030GF277N-T	T927G	9030-OG277
7.5kV, 30mA	7530CPX 277	7B75N3-CB	7530 P5G-2 277	M75030GF277N-T	T7527G	7530-OG277
6kV, 30mA	630C277		N/A	N/A	T627	6030-OG 277
5kV, 30mA	530C277		N/A	N/A	T527	5030-OG 277
4kV, 30mA	430C277		N/A	N/A	T427	4030-OG 277
3kV, 30mA	330C277		N/A	N/A	T327	3030-OG 277
60mA 277V						
15kV, 60mA	1560BPX 277	7B15N6-CB	15060 P5G-2	N/A	S1527G	1560-OG277
12kV, 60mA	1260BPX 277	7B12N6-CB	12060 P5G-2	N/A	S1227G	1260-OG277
9kV, 60mA	960BPX 277	7B09N6-CB	9060 P5G-2	N/A	S927G	9060-OG277
7.5kV, 60mA	7560BPX 277	7B75N6-CB	7560 P5G-2	N/A	S7527G	7560-OG277
6kV, 60mA	660BPX 277		6060 P5G-2	N/A	S627G	6060-OG277
5kV, 60mA	560CPX 277		5060 P5G-2	N/A	S527G	5060-OG277
4kV, 60mA	460CPX 277		4060 P5G-2	N/A	S427G	4060-OG277
3kV, 60mA	360CPX 277		N/A	N/A	N/A	3060-OG277

Cross Reference for UL-2161 Outdoor Style, High Power Factor

	Allanson		France	Magnetek	Transco	Actown
30 mA 120V						
15kV, 30mA	P1530BPX 120	4B15H3-CB	15030 P5CG-2	M15030GF120H-T	4B15H3H-05	N/A
12kV, 30mA	P1230BPX 120	4B12H3-CB	12030 P5CG-2	M12030GF120H-T	4B12H3-05	N/A
10.5kV, 30mA	P1030BPX 120		10530 P5CG-2	N/A	N/A	N/A
9kV, 30mA	P930CPX 120	4B09H3-CB	9030 P5CG-2	M9030GF120H-T	4B09H3-05	N/A
7.5kV, 30mA	P7530CPX 120	4B75H3-CB	7530 P5CG-2	M7530GF120H-T	4B75H3-05	N/A
60 mA 120V						
15kV, 60mA	P1560BPX 120	4B15H6-CB	15060 P5CG-2	N/A	N/A	N/A
12kV, 60mA	P1260BPX 120	4B12H6-CB	12060 P5CG-2	M1260GF120H-T	N/A	N/A
9kV, 60mA	P960BPX 120	4B09H6-CB	9060 P5CG-2	M9060GF120H-T	N/A	N/A
7.5kV, 60mA	P7560BPX 120	4B75H6-CB	7560 P5CG-2	M7560GF120H-T	N/A	N/A
6kV, 60mA	P660BPX 120		6060 P5CG-2	N/A	N/A	N/A
5kV, 60mA	P560CPX 120		5060 P5CG-2	N/A	N/A	N/A
4kV, 60mA	P460CPX 120		4060 P5CG-2	N/A	N/A	N/A
3kV, 60mA	P360CPX 120		N/A	N/A	N/A	N/A

Cross Reference Chart

Cross Reference for UL-2161 Self-Enclosed Style, Normal Power Factor

	Allanson	Lecip	France	Magnetek	Transco	Actown
30 mA 120V						
15kV, 30mA	1530FPX120	4B15N3-EB	1530PKA2NG-1	M15030GF120N-SE	4B15N3-07	1530-VMG
12kV, 30mA	1230FPX120	4B12N3-EB	1230PKA2NG-1	M12030GF120N-SE	4B12N3-07	1230-VMG
10.5kV, 30mA	1030FPX120	4B10N3-EB	1030PKA2NG-1	N/A	4B10N3-07	N/A
9kV, 30mA	930FPX120	4B09N3-EB	930PKA2NG-1	M9030GF120N-SE	4B9N3-07	9030-VMG
7.5kV, 30mA	7530FPX120	4B75N3-EB	7530PKA2NG-1	M7530GF120N-SE	4B75N3-07	7530-VMG
6kV, 30mA	630F120	4B06N3-EB	N/A	N/A	N/A	6030-VM
5kV, 30mA	530F120	4B05N3-EB	N/A	N/A	N/A	5030-VM
4kV, 30mA	430F120		N/A	N/A	N/A	4030-VM
3kV, 30mA	330F120		N/A	N/A	N/A	3030-VM
60 mA 120V						
15kV, 60mA	1560FPX120	4B15N6-EB	1560PKA2NG-1	M15060GF120N-SE	N/A	1560-VMG
12kV, 60mA	1260FPX120	4B12N6-EB	1260PKA2NG-1	M12060GF120N-SE	N/A	1260-VMG
9kV, 60mA	960FPX120	4B09N6-EB	960PKA2NG-1	M9060GF120N-SE	N/A	9060-VMG
7.5kV, 60mA	7560FPX120	4B75N6-EB	7560PKA2NG-1	M7560GF120N-SE	N/A	7560-VMG
6kV, 60mA	660FPX120	4B06N6-EB	N/A	N/A	N/A	6060-VMG
5kV, 60mA	560FPX120	4B05N6-EB	N/A	N/A	N/A	5060-VMG
4kV, 60mA	460FPX120		N/A	N/A	N/A	4060-VMG
3kV, 60mA	360FPX120		N/A	N/A	N/A	3060-VMG

Neon Troubleshooting Guide

The following guidelines have been prepared to assist you perform a disciplined and conservative troubleshooting procedure.

⚠ WARNING

High Voltage is Hazardous. Handling testing and servicing of electrical signs should be performed by qualified personnel. Always Disconnect Primary Power before handling, testing or servicing a sign. Observe OSHA guidelines for safe electrical practices.

All transformers should be properly grounded and installed in accordance with the appropriate Electrical Code as well as in compliance with local ordinances. Proper bonding of high-voltage components is one of the most critical necessities to the effective, safe, long-lasting performance of neon applications.

Begin Troubleshooting

Do an overall inspection of the job conditions: look for evidence of burning, water, dirt, etc; look for obvious broken tubes, defective tubes, insulators, loose or open connections, corrosion caused by corona and/or moisture, improper clearances between energized components and background materials; confirm that supply power is functional and that the breaker is working.

Noise:

After verifying previous conditions, energize the transformer. Listen carefully for noise, especially in form of a hum or a buzz. Noise is an indication of one of the following:

- improper bonding of transformer and/or of other components to ground.
- faulty breaker.
- insufficient power supply or inappropriate wire size.
- overloaded circuit or high current draw.
- the presence of harmonic distortion.

Power supply:

It is important to confirm that the input voltage is within +/- 5% nominal on standard transformers. Confirm amperage rating of cir-

cuit as well as amperage load of circuit. Does it follow the NEC 80% rule? Confirm wire size. Confirm that the transformer and enclosure are grounded.

Note: Maximum voltage between ground and neutral should be 0-5 VAC. Confirm primary wiring polarity.

Secondary wiring:

Check for open circuits, if transformer has been operating over 48 hours on open circuit, replace it. Carefully inspect GTO wire for damage. Check all wiring for shorts and/or grounds. Confirm quality of GTO insulation. (should be rated 15KV and 105°C). Confirm proper bonding of conduit and other metallic components. All secondary conductors must be enclosed in a Listed 1/2" metallic or bonded conduit. Verify that the total length of high voltage cables do not exceed 20 feet / 6 meters.

Transformer loading:

Perform the secondary voltage test for loading and/or flicker test. Ensure the transformer is sized for the conditions of the job.

Other items:

Verify that the transformer is well ventilated.

Cross Reference Chart

Cross Reference for UL-2161 Housing Style, Normal Power Factor

	Allanson	Lecip	France	Magnetek	Transco	Actown
30 mA 120V						
12kV, 30mA	1230EK120		12030 PBKMG-51	M12030G120N-PK	T1212PB	N/A
9kV, 30mA	930EK120	4B09N3-H	9030 PBKMG-51	M930G120N-PK	T912PB	9030-PK
7.5kV, 30mA	7530EK120	4B75N3-H	7530 PBKMG-51	M7530G120N-PK	T7512PB	7530PK
6kV, 30mA	630EK120	4B06N3-H	6030 PBKMG-51	M630G120N-PK	T612PB	6030-PK
5kV, 30mA	530EK120	4B05N3-H	5030 PBKMG-51	M530G120N-PK	T512PB	5030-PK
4kV, 30mA	430EK120		4030 PBKMG-51	M430G120N-PK	T412PB	4030-PK
3kV, 30mA	330EK120		3030 PBKMG-51	M3030G120N-PK	T312PB	3030-PK
60 mA 120V						
12kV, 60mA	1260EK120		N/A	N/A	S1212PB	N/A
9kV, 60mA	960EK120		9060 PBKMG-51	M9060G120N-PK	S912PB	960-PK
7.5kV, 60mA	7560EK120		7560 PBKMG-51	M7560G120N-PK	S7512PB	7560-PK
6kV, 60mA	660EK120		6060 PBKMG-51	M6060G120N-PK	S612PB	6060-PK
5kV, 60mA	560EK120		5060 PBKMG-51	M5060G120N-PK	S512PB	5060-PK
4kV, 60mA	460EK120		4060 PBKMG-51	M4060G120N-PK	S412PB	4060-PK
3kV, 60mA	360EK120		3060 PBKMG-51	M3060G120N-PK	S312PB	3060-PK

Cross Reference for UL-2161 Housing Style, High Power Factor

	Allanson	Lecip	France	Magnetek	Transco	Actown
30 mA 120V						
12kV, 30mA	P1230EK120		N/A	N/A	T1212PBH	N/A
9kV, 30mA	P930EK120		9030 PBKMCG-51	N/A	T912PBH	N/A
7.5kV, 30mA	P7530EK120		7530 PBKMCG-51	N/A	T7512PBH	N/A
6kV, 30mA	P630EK120		6030 PBKMCG-51	N/A	T612PBH	N/A
5kV, 30mA	P530EK120		5030 PBKMCG-51	N/A	T512PBH	N/A
4kV, 30mA	P430EK120		4030 PBKMCG-51	N/A	T412PBH	N/A
3kV, 30mA	P330EK120		3030 PBKMCG-51	N/A	T312PBH	N/A
60 mA 120V						
12kV, 60mA	P1230EK120		N/A	N/A	S1212PBH	N/A
9kV, 60mA	P960EK120		9060 PBKMCG-51	N/A	S912PBH	N/A
7.5kV, 60mA	P7560EK120		7560 PBKMCG-51	N/A	S7512PBH	N/A
6kV, 60mA	P660EK120		6060 PBKMCG-51	N/A	S612PBH	N/A
5kV, 60mA	P560EK120		5060 PBKMCG-51	N/A	S512PBH	N/A
4kV, 60mA	P460EK120		4060 PBKMCG-51	N/A	S412PBH	N/A
3kV, 60mA	P360EK120		N/A	N/A	S312PBH	N/A

Cross Reference for UL-2161 Self Contained Housing Style

	Allanson	Lecip	France	Magnetek	Transco	Actown
30 mA 120V						
12kV, 30mA	1230EKF120		N/A	N/A	N/A	N/A
10.5kV, 30mA	1030EKF120		N/A	N/A	N/A	N/A
9kV, 30mA	930EKF120		9030 PBKMAG-51	N/A	N/A	9030-PKFE
7.5kV, 30mA	7530EKF120		7530 PBKMAG-51	N/A	N/A	7530PKFE
6kV, 30mA	630EKF120		6030 PBKMAG-51	N/A	N/A	6030-PKFE
5kV, 30mA	530EKF120		5030 PBKMAG-51	N/A	N/A	5030-PKFE
4kV, 30mA	430EKF120		4030 PBKMAG-51	N/A	N/A	4030-PKFE
3kV, 30mA	330EKF120		3030 PBKMAG-51	N/A	N/A	3030-PKFE
60 mA 120V						
12kV, 60mA	1260EKF120		N/A	N/A	N/A	N/A
9kV, 60mA	960EKF120		9060 PBKMAG-51	N/A	N/A	N/A
7.5kV, 60mA	7560EKF120		7560 PBKMAG-51	N/A	N/A	N/A
6kV, 60mA	660EKF120		6060 PBKMAG-51	N/A	N/A	N/A
5kV, 60mA	560EKF120		5060 PBKMAG-51	N/A	N/A	N/A
4kV, 60mA	460EKF120		N/A	N/A	N/A	N/A
3kV, 60mA	360EKF120		N/A	N/A	N/A	N/A

Footage Chart

ANSI Luminous Tube Footage Chart

Normal maximum number of feet of tubing operated
(based on average grade of tubing)

Clear or Fluorescent Red
(Also recommended for Neon Fluorescent Gold)

SECONDARY		TUBE SIZE, MILLIMETERS										
kV	mA	25	22	20	18	15	14	13	12	11	10	9
15,000	60	102	85	78	72	60	54	50	45	39	33	27
	30	102	85	78	72	60	54	50	45	39	33	27
	20					50	47	44	40	34	27	24
12,000	60	79	67	61	55	45	42	39	35	30	25	21
	30	79	67	61	55	45	42	39	35	30	25	21
	20					40	38	33	30	26	21	18
10,500	30	73	62	55	48	39	36	34	31	26	22	18
9,000	120	77	65	55	46	38	34	33	30	25	22	17
	60	67	57	48	40	33	30	29	26	22	19	15
	30	67	57	48	40	33	30	29	26	22	19	15
7,500	120	59	47	39	32	28	26	25	23	18	15	13
	60	51	41	34	28	24	23	22	20	16	13	11
	30	51	41	34	28	24	23	22	20	16	13	11
6,000	120	46	39	32	26	22	20	19	18	15	12	10
	60	40	34	28	23	19	18	17	16	13	11	9
	30	40	34	28	23	19	18	17	16	13	11	9
5,000	120	38	32	26	22	19	18	17	14	11	10	8
	60	33	28	23	19	17	16	15	12	10	9	7
	30	33	28	23	19	17	16	15	12	10	9	7
4,000	120					14	13	13	11	8	7	6
	60	27	23	19	16	13	12	11	10	8	7	6
	30	27	23	19	16	13	12	11	10	8	7	6
3,000	120					11	10	10	9	7	6	5
	60	17	14	12	10	10	9	9	8	7	6	5
	30	17	14	12	10	10	9	9	8	7	6	5
2,000	120					8	8	7	6	5	4	4
	60					7	6	6	6	5	4	4
	30					6	5	5	5	4	3	3
Recommended Gas Pressure mm/Hg		6	7	7.5	8	9	10	10	11	12	13	15

The above chart is only a guide.

Deduct approximately one foot from the above figures for each pair of electrodes.

For trouble-free operation, the tubing on each transformer should operate without flicker at 78% of rated primary voltage (approximately 94-volts at a nominal line voltage of 120).

When troubleshooting a neon sign, how can you determine whether a transformer is defective?

Shut off the sign, disconnect the secondary leads at the transformer's output terminals, and connect a portable milliammeter. Turn on the power and check the reading on your meter. The output of a 30-milliamp transformer should be 27 to 33 milliamps. A 60-milliamp transformer's output should be 54 to 66 milliamps. If the transformer does not test

within the corre-

sponding

range, it is

defective

and must be

replaced. If

you are trou-

ble-shooting

a 15,000V

transformer,

each half should

be tested

separately.

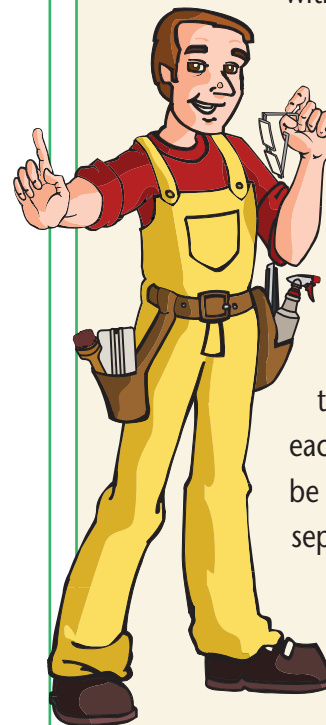

ANSI Luminous Tube Footage Chart

Normal maximum number of feet of tubing operated
(based on average grade of tubing)

Clear or Fluorescent Mercury Filled Tubes, all Colors
Indoor applications (40°F Temp or above)

Clear or Fluorescent Mercury Filled Tubes, all Colors
Outdoor applications (For Temperature Below 40°F)

SECONDARY		TUBE SIZE, MILLIMETERS										
kV	mA	25	22	20	18	15	14	13	12	11	10	9
15,000	60	120	100	90	80	72	64	60	54	47	40	32
	30	120	100	90	80	72	64	60	54	47	40	32
	20					62	56	52	47	40	34	28
12,000	60	95	79	70	62	55	50	46	42	36	30	25
	30	95	79	70	62	55	50	46	42	36	30	25
	20					47	45	40	34	30	26	20
10,500	30	88	73	63	54	48	43	40	37	32	26	22
9,000	120	92	77	63	52	46	41	38	35	30	26	20
	60	80	67	55	45	40	36	33	31	26	23	18
	30	80	67	55	45	40	36	33	31	26	23	18
	20					34	31	29	26	22	18	16
7,500	120	70	55	45	36	32	31	31	27	22	18	14
	60	61	48	39	31	28	27	27	24	19	16	12
	30	61	48	39	31	28	27	27	24	19	16	12
	20					25	25	23	21	17	13	11
6,000	120	55	46	37	30	26	24	23	20	17	14	13
	60	48	40	32	26	23	21	20	18	15	12	11
	30	48	40	32	26	23	21	20	18	15	12	11
	20					20	19	17	16	12	11	8
5,000	120	46	38	31	25	22	22	18	16	14	12	9
	60	40	33	27	22	19	19	16	14	12	11	8
	30	40	33	27	22	19	19	16	14	12	11	8
	20					17	15	15	13	10	8	7
4,000	60	32	27	22	18	16	14	13	12	10	8	7
	30	32	27	22	18	16	14	13	12	10	8	7
	20					13	12	12	11	8	7	6
3,000	60	22	18	16	14	12	10	10	10	8	7	6
	30	22	18	16	14	12	10	10	10	8	7	6
	20					10	9	8	7	6	5	5
2,000	30					9	8	8	7	6	5	5
	20					7	7	7	6	5	4	4
Recommended Gas Pressure mm/Hg		6	7	7.5	8	9	10	10	11	12	13	15

TUBE SIZE, MILLIMETERS											
25	22	20	18	15	14	13	12	11	10	9	
90	76	69	65	54	47	45	40	35	30	24	
90	76	69	65	54	47	45	40	35	30	24	
				45	41	39	36	30	25	20	
71	60	55	49	40	37	36	31	27	22	19	
71	60	55	49	40	37	36	31	27	22	19	
				36	33	29	26	22	19	15	
64	55	47	42	36	32	30	27	23	20	16	
69	59	50	41	35	31	30	26	23	19	15	
60	51	43	36	30	27	26	23	20	17	13	
60	51	43	36	30	27	26	23	20	17	13	
				25	23	22	20	18	13	11	
52	42	35	29	24	23	23	21	17	14	11	
46	37	30	25	21	20	20	18	15	12	10	
46	37	30	25	21	20	20	18	15	12	10	
				19	18	18	16	13	11	9	
41	36	29	23	19	17	17	16	14	11	9	
36	31	25	20	17	15	15	14	12	10	8	
36	31	25	20	17	15	15	14	12	10	8	
				15	14	14	12	9	8	6	
34	29	23	19	17	16	16	14	10	9	7	
30	25	20	17	15	14	14	12	9	8	6	
30	25	20	17	15	14	14	12	9	8	6	
				13	12	12	10	7	6	5	
24	20	17	15	12	11	11	10	7	6	5	
24	20	17	15	12	11	11	10	7	6	5	
				8	6	6	6	5	4	4	
14	12	11	9	9	8	8	7	6	5	4	
14	12	11	9	9	8	8	7	6	5	4	
				8	6	6	6	5	4	4	
				6	6	5	5	5	4	3	
				5	5	4	4	4	3	2	
6	7	7.5	8	9	10	10	11	12	13	15	

The above chart is only a guide.

Deduct approximately one foot from the above figures for each pair of electrodes.

For trouble-free operation, the tubing on each transformer should operate without flicker at 78% of rated primary voltage (approximately 94-volts at a nominal line voltage of 120).

Indoor

Pow-R-Pak™ Neon Power Supply, 120 Volts, 60 Hertz

- **Intelligent diagnostics of ground fault and open circuit protection**, simplifies service and gives you greater security.
- **Overload detection**, gives you the opportunity to properly match the size of your neon sign before the final installation, therefore saving you time, money and the cost of a replacement transformer.
- **Sleeveless GTO # 16 AWG 15 kV and 36" long**, eliminates the need for additional sleeving and GTO splicing, thus minimizes losses.
- **Lightweight and compact**, constructed for tight application, making it more convenient to install the sign.
- **Side exit GTO option**, allowing easier installation in compact applications.



Transformers are UL2161 Listed and CSA Approved.

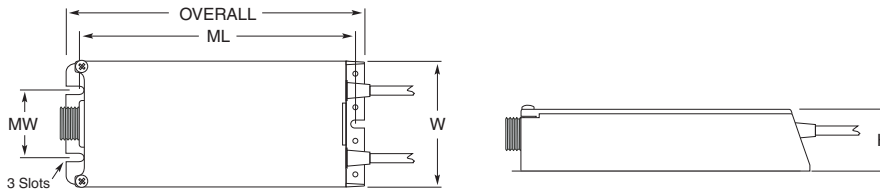

Indoor High Light Output, Self Adjusting Voltage, Normal Power Factor

120 Volts		SECONDARY		PRIMARY	DIMENSIONS IN INCHES					WT. LBS.
ITEM NO.	AMP	KV	MA	VA	OVERALL	W	H	ML	MW	
NA SS1235ICH	2.50	2,000-12,000	35	300	6.477	3	1½	6	1.6	1.9
NA SS1235ICHs Side Exit GTO	2.50	2,000-12,000	35	300	6.477	3	1½	6	1.6	1.9
NA SS1235ICD 50% Dimmer	2.50	2,000-12,000	35	300	6.477	3	1½	6	1.6	1.9
NA SS935ICH	1.50	2,000-9,000	35	100	6.477	3	1½	6	1.6	1.9
NA SS935ICHs Side Exit GTO	1.50	2,000-9,000	35	100	6.477	3	1½	6	1.6	1.9
NA SS935ICD 50% Dimmer	1.50	2,000-9,000	35	100	6.477	3	1½	6	1.6	1.9

NPS Series



- Measuring up to the requirements of UL/CSA standards for neon transformers;
- High power factor and low harmonic distortion;
- Built-in automatic overload protection circuit;
- With pull-chain switch and UL/CSA standard plug, easy to install, most suitable for small neon signs;
- No mercury migration or 'Jelly-bean' effects.

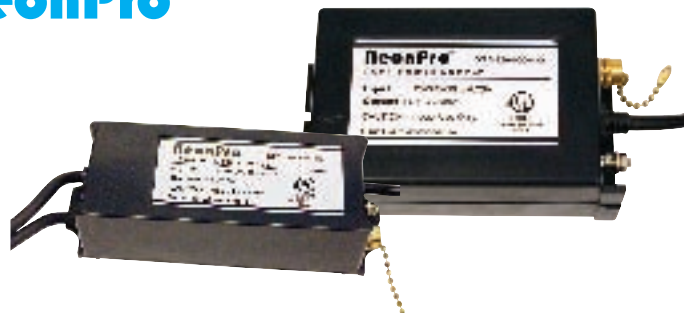

120 Volts		SECONDARY		DIMENSIONS IN INCHES			WT. LB.
ITEM NO.	LINE AMP	KV	mA	L	W	H	
NPS1230I	0.45	12,000	30	6.92	3.7	1.85	2.4
NPS930I	0.75	9,000	30	5.19	3	1.81	1.34
NPS630I	0.5	6,000	30	6.25	2.24	1.65	1.3

Ventex Indoor Neon Power Supplies make it easier for you to create your best neon signage. Smaller, light weight designs allow for simple and quick installation. And Ventex's full 30mA makes your neon signs crisper, brighter and uniform intensity. With several dimming models, you can even tailor the intensity to any environmental situation.



- True 30mA output
- 10 foot power cord
- 9kV and 12kV dimmable models available
- On/Off pull chain or switch
- Available in 120VAC, 220VAC/240VAC
- 32" GTO leads or GTO clamping

UL2161 Listed



120 Volts

ITEM NO.	AMP	SECONDARY		PRIMARY VA	DIMENSIONS IN INCHES					WT. OZS.
		KV	MA		L	H	W	ML	MW	
NVT 4030-120	0.35	100-4,000	30	120	5	1.80	1½	4½	.90	19
NVT 5520-120	0.35	100-5,500	20	120	4.9	1½	.90	4½	¾	14

Indoor/Outdoor UL Type 2 units

120 Volts

ITEM NO.	AMP	SECONDARY		PRIMARY VA	DIMENSIONS IN INCHES					WT. OZS.
		KV	MA		L	H	W	ML	MW	
NVT 5520-120F 18" flying leads for hard wiring!	0.35	100-5,500	20	120	4.9	1½	.90	4½	¾	7
NVT 5520A-120F 18" external leads for flashing!	0.35	100-5,500	20	120	4.9	1½	.90	4½	¾	7

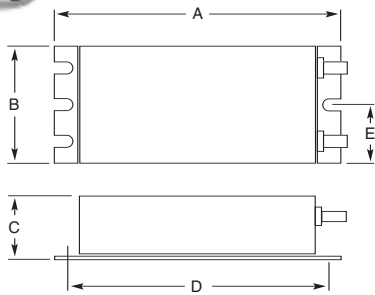

120 Volts

240 Volts

ITEM NO.	LINE AMP	ITEM NO.	LINE AMP	SECONDARY		PRIMARY VA	DIMENSIONS IN INCHES					WT. OZS.
				KV	MA		A	B	C	D	E	
NVT 6030-120	0.6	NVT 6030-240	0.3	100-6,000	30	120	6½	2.05	1.45	6	1.03	24
NVT 9030-120	0.9	NVT 9030-240	0.5	100-9,000	30	120	6½	3.04	1.51	6	1.52	29
NVT 9030D-120 3 level dimming 100%, 65% & 45%	0.9	NVT 9030D-240 3 level dimming 100%, 65% & 45%	0.5	100-9,000	30	120	6½	3.04	1.51	6	1.52	29

120 Volts

240 Volts

ITEM NO.	LINE AMP	ITEM NO.	LINE AMP	SECONDARY		PRIMARY VA	DIMENSIONS IN INCHES					WT. OZS.
				KV	MA		A	B	C	D	E	
NVT 12030-120	1.1	NVT 12030-240	0.6	100-12,000	30	120	6½	3.05	2	6	1.52	32
NVT 12030D-120 2 level dimming 100% & 65%	1.1			100-12,000	30	120	6½	3.05	2	6	1.52	32

Channel Letter

Pow-R-Pak™ Neon Power Supply, 120 Volts, 60 Hertz

- Intelligent diagnostics of ground fault and open circuit protection, simplifies service and gives you greater security.
- Overload detection, gives you the opportunity to properly match the size of your neon sign before the final installation.
- Sleeveless GTO # 16 AWG 15 kV and 36" long, eliminates the need for additional sleeving and GTO splicing, thus minimizes loses.
- Lightweight and compact
- Side exit GTO option

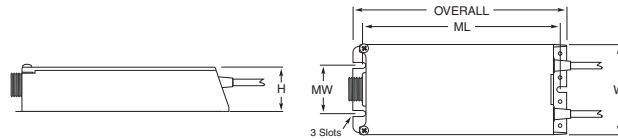

Outdoor High Light Output, Self Adjusting Voltage, Normal Power Factor

120 Volts		SECONDARY		PRIMARY	DIMENSIONS IN INCHES					WT.
ITEM NO.	AMP	KV	MA	VA	OVERALL	W	H	ML	MW	LBS.
NA SS1235BOH	2.50	2,000-12,000	40	120	6 3/8	4	2	5 5/8	2 1/2	3.6
NA SS9600H	3.50	2,000-9,000	60	120	6 3/8	4	2	5 5/8	2 1/2	3.6
NA SS9350H	2.00	2,000-9,000	40	220	6.477	3	1 1/2	6	1.6	1.6
NA SS9350HS Side Exit GTO	2.00	2,000-9,000	40	220	6.477	3	1 1/2	6	1.6	1.6
NA SS6600H	2.50	2,000-6,000	60	200	6.477	3	1 1/2	6	1.6	1.6
NA SS6350H	1.50	2,000-6,000	40	200	6.477	3	1 1/2	6	1.6	1.6
NA SS6350HS Side Exit GTO	1.50	2,000-6,000	40	200	6.477	3	1 1/2	6	1.6	1.6

Transformers are UL2161 Listed and CSA Approved.



Aluma-Pak™ Outdoor Neon Power Supply

- Packed in metal to work on metal
- Extruded case and solid fill provide maximum water resistance
- The most advanced GFI technology available
- Auto reset bypass and LED display

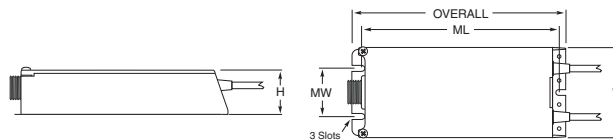

120 Volts		SECONDARY		PRIMARY	DIMENSIONS IN INCHES					WT.
ITEM NO.	AMP	KV	MA	VA	OVERALL	W	H	ML	MW	LBS.
NA SS1235OX	2.5	2,000-12,000	35	300	7.840	3.050	1.5	7.250	1.840	2.2
NA SS935OX	2.5	2,000-9,000	35	250	7.840	3.050	1.5	7.250	1.840	2.2
NA SS635OX	2.5	2,000-6,000	35	180	7.840	3.050	1.5	7.250	1.840	2.2

Transformers are UL2161 Listed and CSA Approved.



CL Neon Power Supplies for Outdoor Channel Letter Signs



Designed Especially for Channel Letters — Ventex's UL 2161 CL family of neon power supplies are engineered to make channel letter construction and installation easier, faster, and economical. With exclusive Ventex Generation III electronics you eliminate most installation problems – your signs will stay running through transient voltage spikes or brownouts! Plus, Ventex's High Power Factor circuitry will save users up to 66% on energy costs over traditional electromagnetic transformers.

- Output available in 30mA and 60mA
- Available in 120VAC, 220/240VAC and 277VAC
- 1/2" conduit fitting for primary wiring
- No primary polarity restrictions
- Circuitry included for surge suppression
- Operating temperature range -30° to 122°F (-34° to 50°C)
- White enclosures eliminate shadows
- Low profile 1.5" or less fits under the tube

UL2161 Listed

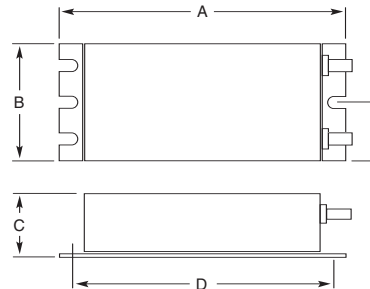

120 Volts		240 Volts		277 Volts		SECONDARY		PRIMARY	DIMENSIONS IN INCHES					WT. OZ.
ITEM NO.	LINE AMP	ITEM NO.	LINE AMP	ITEM NO.	LINE AMP	KV	MA	VA	A	B	C	D	E	
NVT 4030CL-120	0.35			NVT 4030CL-277	0.2	100-4,000	30		5	1.80	1½	4½	0.90	14
NVT 6030CL-120	0.6	NVT 6030CL-240	0.3			100-6,000	30		7½	1.96	1.45	6½	0.94	23
NVT 9030CL-120	0.9	NVT 9030CL-240	0.5	NVT 9030CL-277	0.5	100-9,000	30		6.65	3	1½	6.13	1.55	34
NVT 12030CL-120	1.5					100-12,000	30		8½	3½	1½	8.13	1¼	52
NVT 6060CL-120	1.8					100-6,000	60		6.65	3	1½	6.13	1.55	34
NVT 9060CL-120	1.85			NVT 9060CL-277	0.9	100-9,000	60		8½	3½	1½	8.13	1¼	52

12VDC

12VDC Power Supplies



The widest variety of 12VDC electronic power supplies to light your neon!

Choose from constant burn or express your creativity with specialty neon power supplies –

- Animation/Flashing - with external controller
- Scripting - a flowing motion of light through the tube
- Designed for energy efficient operation
- So small you can mount them virtually anywhere
- All units feature 18" GTO leads

- UL 2161 Listed, CUL Approved
- Small size and light weight
- New 12 VDC molded plug connector
- No special tube processing required
- Utilizes standard gas pressures
- Safe, 12VDC low voltage

UL2161 Listed



VT 1510-12



VT 4015-12

Featuring a molded 12VDC plug

VT 4015A-12F

For animating and flashing neon

12VDC									
ITEM NO.	mA	SECONDARY		PRIMARY VA	DIMENSIONS IN INCHES				WT. OZ.
		V	mA		L	H	W	M	
NVT 1510-12	650	1,500	10		1½	2¼	1	1.15	3
NVT 4015-12	1400	4,000	15		3.8	1.3	1.8	3½	8
NVT 4015A-12F	1400	4,000	15		3.8	1.3	1.8	3½	8

AC/DC Wall Adapter

for low voltage neon power supplies

- UL/CUL and internationally approved
- Powers all 12VDC Ventex electronic transformers
- Custom design minimizes AC ripple in DC output
- 10 foot (3m) power cord
- In-line on/off switch
- Durable molded rubber connector plug
- Female output jack center positive: 2.5mm x 5.5mm x 9.0mm
- Wide operating temp: 0° to 104°F (-18° to 40°C)



WA 1500US

for use with VT 1510-12, VT 4015-12 or VT 4015A-12F

Input/Output:	120 V (±10%) /12 VDC
Output Current:	1500 mA
Length:	3.25 in.
Width:	2.5 in.
Height:	2.1 in.
Weight:	28 oz.

ITEM NO. NVWA1500



www.sfsupplies.com

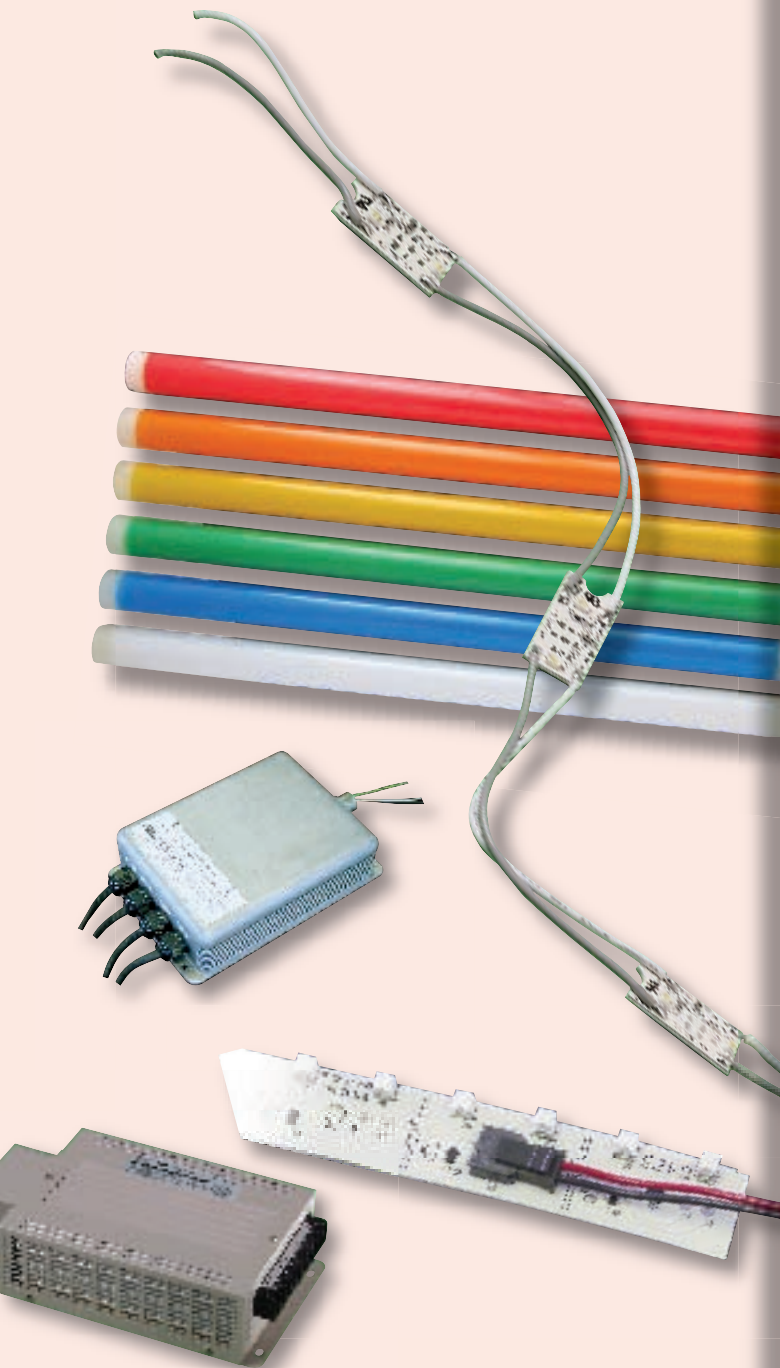

INDEX

DIGITAL MEDIA	5
SIGN VINYL	45
VINYL AND WRAP SUPPLIES	59
WIDE FORMAT EQUIPMENT	73
VINYL CUTTERS	87
ENGRAVERS	95
SOFTWARE	97
SUBSTRATES	105
BANNER	127
SIGN DISPLAY	139
TAPES & ADHESIVES	145
PAINT	153
NEON SUPPLIES & EQUIPMENT	167
TRANSFORMERS	207
LED SYSTEMS	229
DURA LED	
Channel Letter and Sign Cabinet	230
SLOAN	
Overview	231
Channel Letter and Sign Cabinet.....	232-233
LED Tubing.....	234-235
Power Supply	236
PERMLIGHT	
Channel Letter and Sign Cabinet.....	237-239
Power Supply	240
NEON PRO	
Channel Letter.....	241
ALLANSON	
RGB Channel Letter.....	241
LIGHTING & ELECTRIC	243
SIGN EXTRUSION	267
LETTER & ACCESSORIES	277
MOUNTING HARDWARE	281
EQUIPMENT & SHOP TOOLS	293

Channel Letter and Sign Cabinet

Dura LED Short 2

Short ChanneLED Module
High Brightness

Perfect solution for face-lit channel letters and sign cabinets installed in normal and/or extremely damp or wet weather environments.

- IP68: dry, damp, and wet locations
- 120° Viewing angle
- UL Recognized (SAM) for US & Canada, CE

Dimensions LxWxH: 1.50" x 0.47" x 0.28"
LED's per module: 2
Modules per foot: 3
Mounting: Double-sided tape

ITEM NO.	COLOR	POWER PER MODULE (WATTS)	DOMINANT WAVELENGTH	LUMENS PER FOOT	MODULES PER 60W POWER SUPPLY	LIMITED WARRANTY
DLS2WHT	White	0.48	8500k	95.5	105 (35ft.)	4 Years
DLS2RED	Red	0.30	625 nm	30.0	165 (55ft.)	4 Years
DLS2GR	Green	0.48	525 nm	61.9	105 (35ft.)	4 Years
DLS2BL	Blue	0.48	460 nm	13.7	105 (35ft.)	4 Years

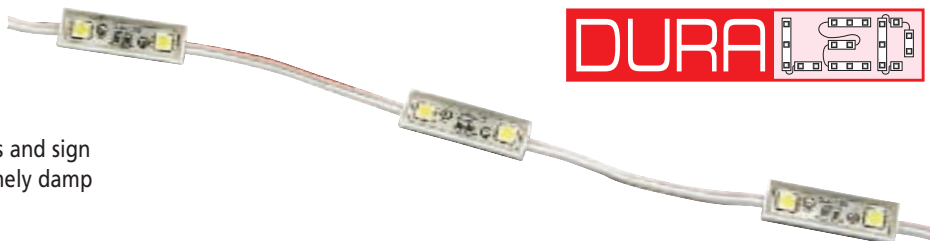

Dura LED Medium 3

Medium ChanneLED Module
High Brightness

Perfect solution for face-lit channel letters and sign cabinets installed in normal and/or extremely damp or wet weather environments.

- IP68: dry, damp, and wet locations
- 120° Viewing angle
- UL Recognized (SAM) for US & Canada, CE

Dimensions LxWxH: 2.60" x 0.59" x 0.28"
LED's per module: 3 (RGB: 3x 3-in-1)
Modules per foot: 2
Mounting: Double-sided tape

ITEM NO.	COLOR	POWER PER MODULE (WATTS)	DOMINANT WAVELENGTH	LUMENS PER FOOT	MODULES PER 60W POWER SUPPLY	LIMITED WARRANTY
DLM3WHT	White	0.72	8500k	95.5	70 (35ft.)	4 Years
DLM3RGB	RGB	0.72	8500k	95.5	70 (35ft.)	4 Years



Dura LED RGB Full Color Controller

ITEM NO. DLCRGB





Product Selection Guide

SloanLED has established itself as the preeminent brand of LED lighting products in the sign market. Committed to providing the sign trade with the highest quality LEDs, the broadest selection of products and the very best customer support, SloanLED offers LED solutions for nearly every application. From the smallest halo-lit letters, to the biggest face-lit channel letters. From the largest global border tubing programs, to the most unusual one-time accent tubing job. From the most demanding environments, to the most challenging installations. SloanLED has the innovation, experience and selection needed to make your LED signage projects successful.



Channel Letters and Sign Cabinets

Easy-to-use sign LED lighting systems are now brighter and more versatile than ever before.

PRODUCT	KEY ATTRIBUTES	APPLICATION	COLORS							TEMPERATURE		
			RED	RED/ORANGE	ORANGE	AMBER	YELLOW	GREEN	BLUE	WHITE	WARM WHITE	SOFT WHITE
ChannelLED 5	Wide viewing angle, Extendable wire (+2") feature, Fewer modules/ft.	Medium/large face lit or halo lit signs, Digital/vinyl graphics, Cove lighting									X	X
V Series	Wide viewing angle, low profile modules	Shallow, small, narrow face or halo lit signs, Color face lit signs in all sizes	X	X	X	X	X	X	X	X	X	X
Apollo	IP68 rated, Most efficient LED, Soft white color	Medium to large face lit signs										X
Value-Line	Most economical solution, Long leg lengths	Three sizes available for small, medium & large channel letters and halo lit signs	X								X	
Great White 3	Wide viewing angle, Snap and Stretch - create two functional modules for optimum module placement and brightness	Large/deep letters, sign cabinets, cove lighting, custom vinyl color faces									X	
ThinLED	Flexible strips, extremely	Small halo letters, edge-lit signs narrow, very uniform light pattern	X			X	X	X	X	X		



LED Tubing

Create neon like looks with an eco-friendly LED-based tubing, available in an array of colors.

PRODUCT	KEY ATTRIBUTES	APPLICATION	RED	ORANGE	AMBER	YELLOW	GREEN	BLUE	WHITE
ColorLINE	Neon-like profile, high brightness, easily cut in the field, low power consumption	Small profile border, perimeter, accent, display and exhibit lighting	X	X		X	X	X	X
FlexiBRITE	Flexible tubing, pre-assembled/sealed, shape on the fly without heating	Free-form shapes, logos, letters, accent, open face channel letters	X	X		X	X	X	
LEDStripe	High impact rigid tubing, ultra-bright LEDs, day-time color when unlit	Large profile border, perimeter, accent, display and exhibit lighting	X	X	X	X	X	X	X

Channel Letter and Sign Cabinet

Apollo

IP68 ChanneLED Module

Apollo LED Lighting System uses one of the most energy efficient LEDs on the market today. It is 50% brighter while requiring 50% less power than ChanneLED 5 and comes in an attractive soft white color. Apollo has a robust module design (IP68 Ingress Protection), making it the perfect solution for face-lit channel letters and sign cabinets installed in normal and/or extremely damp or wet weather environments.

- Attractive Soft White color
- 150° Viewing angle
- Able to run 56 feet per 60W 12 VDC SloanLED power supply
- Completely sealed module (IP68)
- Constant Current Technology



Dimensions LxWxH:	3/2" x 3/8" x 5/8"
LED's per module:	3
Modules per foot:	2
Mounting:	Peel-n-stick and mechanical

ITEM NO.	DESCRIPTION	POWER PER MODULE (WATTS)	MAX COVERAGE PER ROW	LIMITED WARRANTY
SL-CL6-WHT	Soft White (5000K)	0.48 Watts		5 Years

ChanneLED 5

Brilliantly simple, creating the new standard

For medium to large face lit and halo signs

Now with brighter LEDs and wider viewing angles, CL5 offers simplicity and flexibility while providing bright, vivid and uniform illumination for face-lit channel letters, sign cabinets, cove lighting and an endless array of low-voltage applications.

- Brighter LEDs
- Wider viewing angles
- Extendable wire (+2") feature
- Constant Current Technology
- Pre-wired modules for optimal placement

SloanStretch - pull for an additional 2" of wire when you need it.

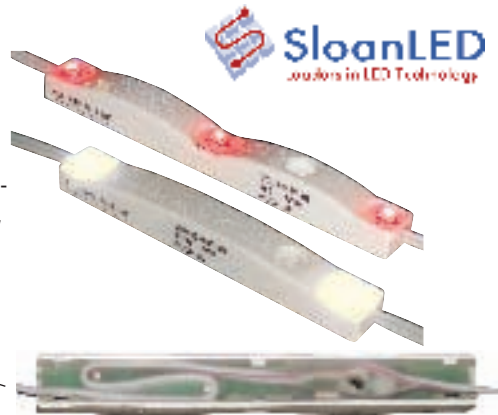

Dimensions LxWxH:	Red: 4" x 7/16" x 7/16" Whites: 3 3/8" x 7/16" x 7/16"
LED's per module:	Red: 3, Whites: 2
Modules per foot:	2
Mounting:	Peel-n-stick and mechanical

ITEM NO.	COLOR	POWER PER MODULE (WATTS)	MAX COVERAGE PER ROW	LIMITED WARRANTY
SL-CL5-RED	Red	0.6	5"	5 Years
SL-CL5-WHT	White	0.9	4"	5 Years
SL-CL5-WWHT	Warm White	0.9	4"	5 Years

V Series Versatile LED lighting system

For shallow/small/narrow face lit or halo signs

V Series is the brightest LED module in its class - versatile enough for many applications and the perfect solution for shallow channel letters and small halo lit letters.

- 8 vivid colors
- Wide viewing angle
- Low profile modules
- Constant Current Technology
- Pre-wired modules for optimal placement

Dimensions LxWxH:	2 1/4" x 7/16" x 3/8"
LED's per module:	2
Modules per foot:	3
Mounting:	Peel-n-stick and mechanical



ITEM NO.	COLOR	POWER PER MODULE (WATTS)	DOMINANT WAVELENGTH	MAX COVERAGE PER ROW	LIMITED WARRANTY
SL-CLVS-RED	Red	0.6	630 nm	4"	5 Years
SL-CLVS-RDOR	Red/Orange	0.6			5 Years
SL-CLVS-OR	Orange	0.6	609 nm	5"	5 Years
SL-CLVS-YEL	Yellow/Amber	0.6		4"	5 Years
SL-CLVS-GR	Green	0.6	528 nm	4"	5 Years
SL-CLVS-BL	Blue	0.6	471 nm	4"	5 Years
SL-CLVS-WHT	White (7200K)	0.6	Cool	4"	5 Years
SL-CLVS-SW	Soft White (5000K)	0.6			5 Years
SL-CLVS-WW	Warm White (4200K)	0.6	Warm	4"	5 Years

Channel Letter and Sign Cabinet

Value-Line

A lot of Xtras at a great price

The Value-Line is based on proven SloanLED channel letter module design and performance. Available in two colors and three sizes, the Value-Line offers a variety of solutions for the price conscious customer.

- Xtra brightness - 25 to 50% brighter than current ChanneLED 4
- Xtra length - up to 75' per SloanLED power supply
- Constant Current Technology (CCT)
- Pre-wired modules for optimal placement
- DC 12 V throughout for mix-n-match compatibility

Dimensions LxWxH: Long: 4"x 1/2" x 9/16"
Short: 2"x 1/2" x 9/16"
Mini: 1 1/8" x 7/16" x 1/2"

LED's per module: Long:3, Short, Mini:2

Modules per foot: Long:2, Short:3, Mini:4

Mounting: Peel-n-stick and mechanical

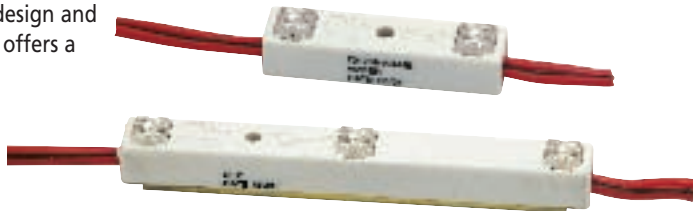

ITEM NO.	DESCRIPTION	POWER PER MODULE (WATTS)	MAX COVERAGE PER ROW	LIMITED WARRANTY
SL-CL4-WHT-L	White Long (6800K)	0.36 Watts	5"	5 Years
SL-CL4-WHT-S	White Short (6800K)	0.36 Watts	5"	5 Years
SL-CL4-WHT-M	White Mini (6800K)	0.27 Watts	5"	5 Years
SL-CL4-RED-L	Red Long	0.6 Watts	5"	5 Years
SL-CL4-RED-S	Red Short	0.6 Watts	5"	5 Years

Great White 3 High-Output White LEDs

Bright white, wide/deep/tall face lit signs

An advanced high output white LED system. Provides an even, bright white illumination for wide, deep and tall lettersets and sign cabinets, while using fewer modules.

- Advanced high output white LED system
- Even, bright illumination with fewer modules
- Snap and Stretch modules - create two half modules for optimum placement for maximum brightness
- Constant Current Technology

Dimensions LxWxH: 6 x 1 x .5"

LED's per module: 4

Modules per foot: 1.5

Mounting: Peel-n-stick and mechanical



ITEM NO.	DESCRIPTION	POWER PER MODULE (WATTS)	MAX COVERAGE PER ROW	LIMITED WARRANTY
SL-CL4-WHT-G	Great White 3	2.4 Watts	6"	5 Years

ThinLED Halo lit LEDs

A favorite solution for narrow halo-lit "reverse lit" channel letters, edge-lit signs or any indirect lighting application with thin strokes or channels.

- Strip dimensions: 12"L x 3/4"H x 3/8"W
- Can be bent to a 1" radius, fits in strokes as narrow as 3/8" and can be cut to size
- Strip maintains its shape once bent for easy and secure mounting
- Each strip includes one 6" jumper

ITEM NO.	DESCRIPTION	CUT INCREMENTS	LEDs PER 12" STRIP	POWER PER 12" STRIP	LIMITED WARRANTY
SL-THIN-RED	Red	2.0"	18	2.2 Watts	5 Years
SL-THIN-AMB	Amber	2.0"	18	2.2 Watts	5 Years
SL-THIN-YEL	Yellow	2.0"	18	2.2 Watts	5 Years
SL-THIN-GR	Green	1.33"	18	2.2 Watts	3 Years
SL-THIN-BL	Blue	1.33"	18	2.2 Watts	3 Years
SL-THIN-WHT	White	1.33"	18	2.2 Watts	3 Years

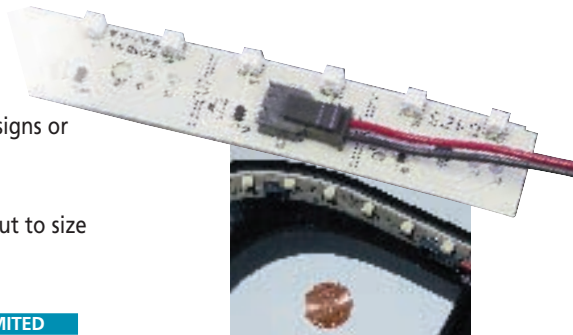

Mounts onto the Return



Beautiful Halo Lighting

Jumpers ITEM NO. SL-JUMPERS

Cable & wire nuts on page 235

LED Tubing

ColorLINE LED Border Tubing



Add stunning visual appeal and increased awareness to any building with this new, patented LED-based rigid tubing system. Completely assembled and sealed tubes are ready for installation out of the box. ColorLINE, the latest LED tubing product from SloanLED, offers our brightest light output, a neon-like profile and innovative lit, mitered corners.

- Wide viewing-angle LEDs offer uniform glow
- High impact, UV stable, hydrocarbon insensitive, non-fading material
- Can be cut-to-fit in the field and factory bent down to an 8" radius
- Convenient, weatherproof connectors between sections
- Operating temperature: -40°C to +85°C
- Conforms to UL 48 standards, is CE Certified and ETL Listed system
- Compatible with 12 VDC products and Power Supplies

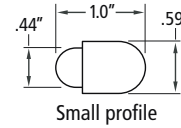
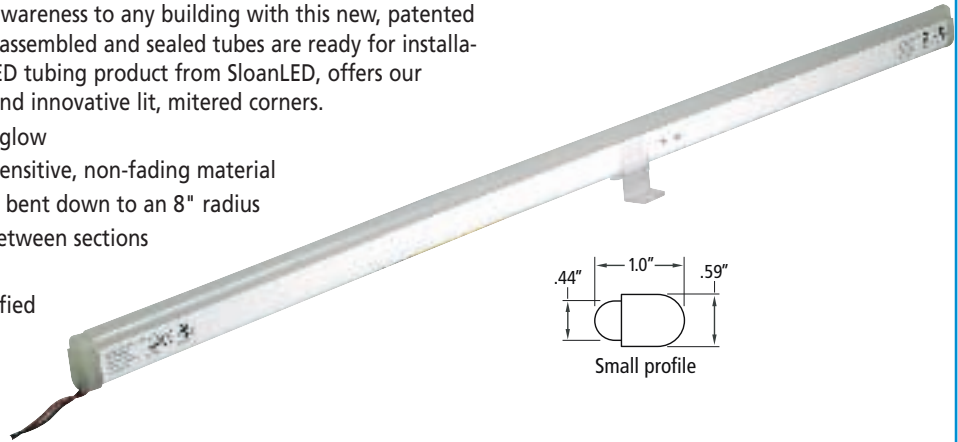

ITEM NO.	DESCRIPTION	ACTUAL TUBE LENGTH	APPROX. CUT INCREMENTS	POWER PER FOOT	LIMITED WARRANTY
SL-COL-(COLOR)-2	2' Tube	24½"	2.4"	2.28 Watts	Red, Orange, Yellow 5 Years
SL-COL-(COLOR)-4	4' Tube	48½"	2.4"	2.28 Watts	Green, Blue, White 3 Years
SL-COL-(COLOR)-6	6' Tube	72½"	2.4"	2.28 Watts	
SL-COL-(COLOR)-8	8' Tube	96½"	2.4"	2.28 Watts	

FlexiBRITE Flexible LED Tubing



As the first completely flexible LED tube light, FlexiBRITE can create an endless array of profiles, contours and patterns on the fly. Ideal for exterior and interior lighting applications such as sign perimeters, letters, symbols, accent stripes, borders and open-face channel letters. Complete compatibility with ChanneLED4 and ThinLED CC means FlexiBRITE can add that "neon look" to any LED-lit sign.

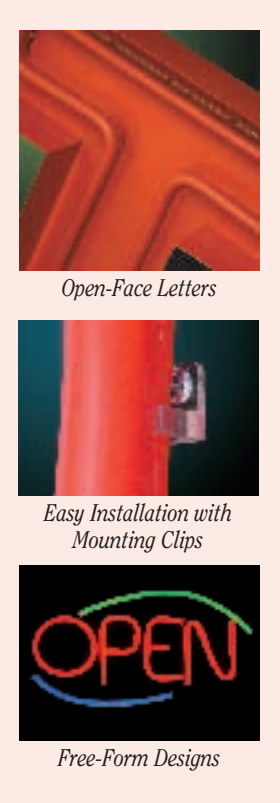
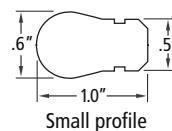
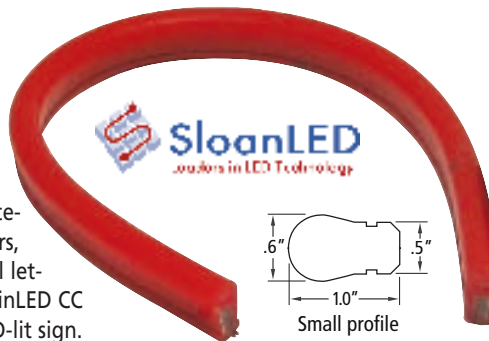

Open-Face Letters

Easy Installation with Mounting Clips

Free-Form Designs

- Bright, wide viewing-angle LEDs offer intense, uniform glow for perimeter/accent lighting
- Ideal for exterior or interior signage, letters, symbols, accent stripes, borders, cove lighting
- Prewired, completely sealed, waterproof tubes can be cut-to-fit, spliced and resealed
- Packaged in easy-to-use 2' or 10' kits containing end caps and mounting clips

ITEM NO.	DESCRIPTION	CUT INCREMENTS	LEDs PER FOOT	POWER PER FOOT	LIMITED WARRANTY
SL-FLB-RED-Size	Red Kit	2.0"	24	2.8 Watts	5 Years
SL-FLB-O-size	Orange Kit	2.0"	24	2.8 Watts	5 Years
SL-FLB-Y-size	Yellow Kit	2.0"	24	2.8 Watts	5 Years
SL-FLB-G-size	Green Kit	1.0"	24	2.8 Watts	3 Years
SL-FLB-B-size	Blue Kit	1.0"	24	2.8 Watts	3 Years

End Caps

ITEM NO. SL-FLB-EC-Color



Mounting Clips

ITEM NO. SL-FLB-MC



Cable & wire nuts on page 235

LEDStripe

Large profile LED tubing

Add stunning visual appeal and increased awareness to any building with this popular LED-based rigid tubing system from SloanLED. Completely sealed and finished tubes are ready for installation out of the box. LEDStripe is the border tube system of choice for many retail, restaurant, petroleum and lodging chains. Easy to quote, easy to install and easy to maintain.

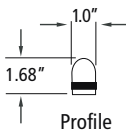

12 colors to choose from

Warm Colors: Red, Orange, Amber

Cool Colors: Lemon Yellow, Green, Blue, White
Also Pastels

- Daytime color when non-illuminated
- High impact acrylic: UV stable, hydrocarbon insensitive, non-fading
- One cut per tube can be made in the field
- Uses 24 Volt AC transformer
- Can be cut-to-fit in the field and factory bent to an 8" radius
- Convenient lock-tight, waterproof connectors between tubes
- Operating temperature: -40°C to +70°C



Custom Bending

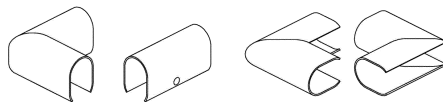

Variety of Joint Covers and Corners



ITEM NO.	DESCRIPTION	CUT INCREMENTS	LEDs PER FOOT	POWER PER FOOT	LIMITED WARRANTY
SL-LEDST-color-1	1' Tube	1.00"	2.8 Watts		
SL-LEDST-color-2	2' Tube	3.00"	2.8 Watts	Warm colos: 30 (99)	Warm colos: 5 Years
SL-LEDST-color-4	4' Tube	3.00"	2.8 Watts		
SL-LEDST-color-6	6' Tube	3.00"	2.8 Watts	Cool colos: 24 (79)	Cool colos: 3 Years
SL-LEDST-color-8	8' Tube	3.00"	2.8 Watts		
SL-LEDST-color-10	10' Tube	3.00"	2.8 Watts		

SloanLED Cable

ITEM NO.	DESCRIPTION
SL-CABLE	100'
SL-CABLE-1000	1000'



SloanLED Wire Nuts

ITEM NO. SL-WN



In-Line Splice Connector

ITEM NO. SL-ILSC



Power Supplies

Power Supplies



12 VDC Power Supply

- Simple primary hook-ups, Class 2 outputs
- Simple secondary hookups - no minimum load, no load balancing and no dip switches
- Proven reliability, rugged housings
- Limited warranty of up to 5 years



Self Contained 20



Modular 60
Now rated ip68

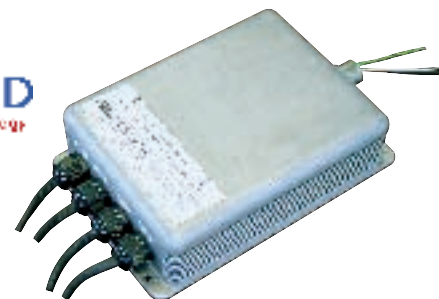

Quad 240

SL-PS-701480

For ChanneLED4, ThinLED CC, FlexiBRITE & ColorLINE

ITEM NO.	DESCRIPTION	NOMINAL INPUT VOLTAGE	INPUT CURRENT	OUTPUT VOLTAGE	POWER OUTPUT	ENCLOSURE SPEC			OVERALL DIMENSIONS (LxWxH)
						DRY	DAMP	WET	
SL-PS-701680	Self Contained 20	120/240 Volts	.3 Amps	12 VDC	20 Watts	X	X		3.75" x 1.6" x 1"
SL-PS-701507-M	Modular 60	120/240 Volts	1.0 Amps	12 VDC	60 Watts	X	X	X	9" x 2.5" x 2"
SL-PS-701507-2	Modular 60-277	277/347 Volts	0.5 Amps	12 VDC	60 Watts	X	X	X	10.5" x 2.5" x 2"
SL-PS-701494	Quad 240	120 Volts	3.6 Amps	12 VDC	240 Watts	X	X	X	9.5" x 6" x 2.4"
SL-PS-701480	Plugin Power Supply								

All power supplies carry required UL designation in U.S. and Canada

- Simple primary hook-ups, Class 2 outputs
- Simple secondary hookups - no minimum load, no load balancing and no dip switches
- Proven reliability, rugged housings
- Limited warranty of up to 5 years

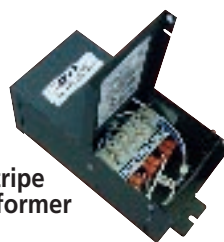

LEDStripe Transformer

ITEM NO.	DESCRIPTION	NOMINAL INPUT VOLTAGE	INPUT CURRENT	OUTPUT VOLTAGE	POWER OUTPUT	ENCLOSURE SPEC		OVERALL DIMENSIONS (LxWxH)
						DRY	DAMP	
SL-PS-700940	LEDStripe 120V	120 V/60 Hz	3.0 Amps	24 VAC	300 Watts	X	X	8.75" x 4.4" x 4.1"
SL-PS-700940-240	LEDStripe 240V	240 V/50 Hz	1.5 Amps	24 VAC	300 Watts	X	X	8.75" x 4.4" x 4.1"
SL-PS-700964	LEDStripe 277V	277 V/60 Hz	1.5 Amps	24 VAC	300 Watts	X	X	8.75" x 4.4" x 4.1"

All power supplies carry required UL designation in U.S. and Canada

Channel Letter and Sign Cabinet

TwisterNANO 737 Series

TwisterNANO is a complete system which is ideal for illuminated face, reverse/halo or cove lighting. The low-profile, tiny size and flexible design fits into very small channel letters and narrow coves. TwisterNANO is conformal coated to resist moisture and harsh exterior conditions. The wide beam viewing angle allows mounting in shallow channel letters or coves providing even illumination.

- Tiny size, low-profile and flexible lighting system
- Ideal for small illuminated face letters or reverse/halo
- Weather resistant conformal coating
- Simple "peel & stick" installation
- Available in multiple colors

Input:	12 VDC nominal, 12.3VDC maximum
Dimensions:	0.25" x 0.75" x 0.13" (not including wires)
Spacing:	6 modules per foot, 2" on centers
Mounting:	Supplied VHB tape on back of module
Power per module:	0.45 watts
Warranty:	5 years

PERMIGHT

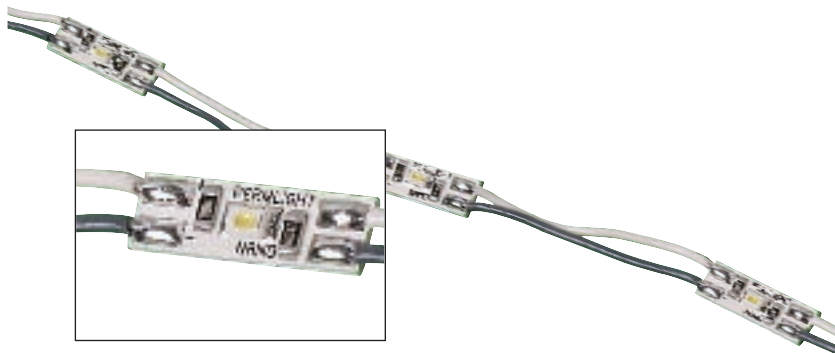

ITEM NO.	COLOR	ESTIMATED LIFE (HOURS)
PERM-737-WHT	Neon white - 6500K	40,000
PERM-737-WW	Warm White - 2850K	40,000
PERM-737-BLUE	Blue - 470nm	40,000
PERM-737-GREEN	Green - 525nm	40,000
PERM-737-AMBER	Amber - 590nm	100,000
PERM-737-ORANGE	Orange - 605nm	100,000
PERM-737-RED	Ruby Red - 630nm	100,000

TwisterHALO 787 Series

TwisterHALO is specifically designed for shallow channel letters for reverse/halo lighting. TwisterHALO's side-fire LED and close module spacing of 3" on center makes it perfect for mounting inside the back of the channel letter. The side-firing LED bounces the light back-and-forth on the returns and creates a soft, even illumination without "hots spots" or "points of light".

- "Side-fire" LED for very shallow reverse/halo lighting
- Compact, low-profile and flexible lighting system
- Weather resistant conformal coating
- Simple "peel & stick" installation
- Available in blue and white

Input:	12 VDC nominal, 12.3VDC maximum
Dimensions:	0.5" x 1.0" x 0.13" (not including wires)
Spacing:	4 modules per foot, 3" on centers
Mounting:	Supplied VHB tape on back of module Built-in notch can be used to attach with screw or rivet
Power per module:	0.45 watts
Warranty:	5 years

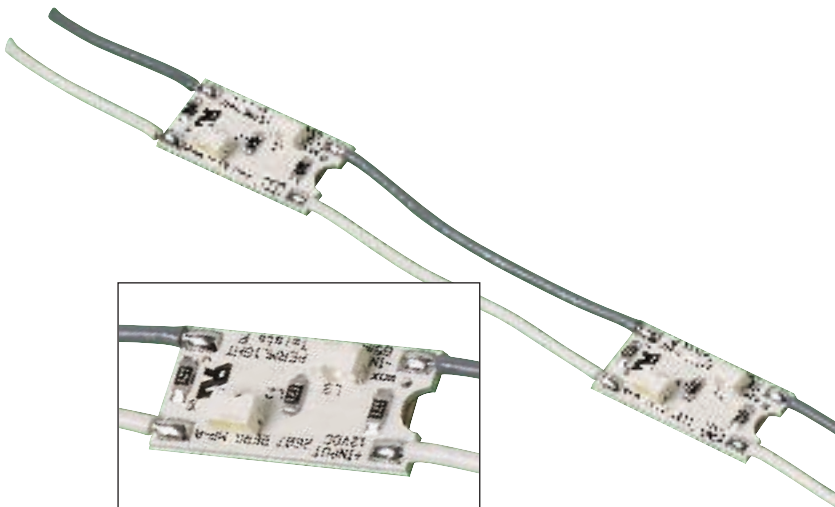

ITEM NO.	COLOR	ESTIMATED LIFE (HOURS)
PERM-787-WHT	Neon white - 6500K	40,000
PERM-787-BLUE	Blue - 470nm	40,000
PERM-787-GREEN	Green - 525nm	40,000

Channel Letter and Sign Cabinet

Twister 752 Series

Twister is a complete system which is ideal for illuminated face, reverse/halo or cove lighting. The low-profile, compact size and flexible design fits into small and medium channel letters and narrow coves. Twister's wide beam viewing angle allows mounting on returns of channel letters or in shallow coves providing even illumination.

- Compact, low-profile and flexible lighting system
- Ideal for illuminated face, reverse/halo and cove
- Weather resistant conformal coating
- Simple "peel & stick" installation
- Available in multiple colors

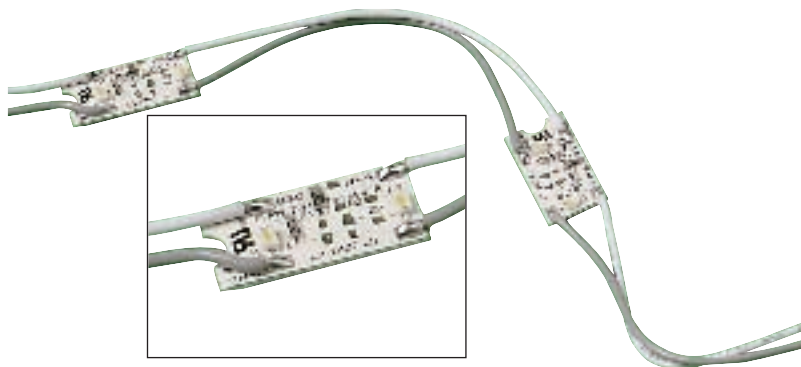

Input:	12 VDC nominal, 12.3VDC maximum
Dimensions:	0.5" x 1.0" x 0.13" (not including wires)
Spacing:	3 modules per foot, 4" on centers
Mounting:	Supplied VHB tape on back of module Built-in notch can be used to attach with screw or rivet
Power per module:	0.6 watts
Warranty:	5 years

ITEM NO.	COLOR	ESTIMATED LIFE (HOURS)
PERM-TR-WHT	Cool white - 6500K	40,000
PERM-TR-INCAN	Warm White - 2850K	40,000
PERM-TR-BLUE	Blue - 470nm	40,000
PERM-TR-GR	Green - 525nm	40,000
PERM-TR-AMBER	Amber - 590nm	100,000
PERM-TR-OR	Orange - 605nm	100,000
PERM-TR-RR	Ruby Red - 630nm	100,000

TwisterSTAR 753 Series

Twister STAR is a complete system which is ideal for illuminated face, reverse/halo or cove lighting. The lowprofile, compact size and flexible design fits into small and medium channel letters and narrow coves. The wide beam viewing angle allows mounting on returns of channel letters or in shallow coves providing even illumination.

- Compact, low-profile and flexible lighting system
- Ideal for illuminated channel letters
- Weather resistant conformal coating
- Simple "peel & stick" installation
- Available in multiple colors

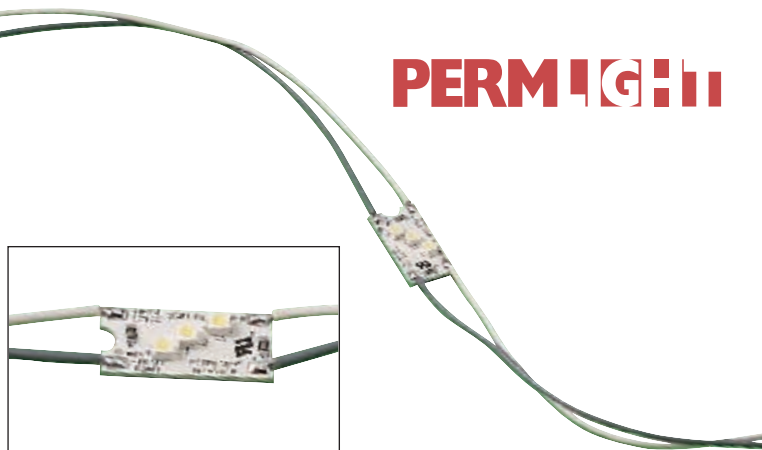

Input:	12 VDC nominal, 12.3VDC maximum
Dimensions:	0.50" x 1.0" (not including wires)
Spacing:	2 modules per foot, 6" on centers
Mounting:	Supplied VHB tape on back of module Built-in notch can be used to attach with plastic screw or rivet
Power per module:	0.5 watts
Warranty:	5 years

ITEM NO.	COLOR	ESTIMATED LIFE (HOURS)
PERM-753-WHT	Neon White (6500K)	40,000
PERM-753-RED	Ruby Red (630nm)	100,000

Channel Letter and Sign Cabinet

Twister NITRO 777 Series

Twister Nitro is like the standard Twister except it is over three times brighter and has a similar light output to 60mA neon.

- Equivalent light output to a 60mA neon
- Compact, low-profile and flexible lighting system
- Ideal for illuminated face, reverse/halo
- Weather resistant conformal coating
- Simple "peel & stick" installation
- Available in multiple colors

PERMIGHT

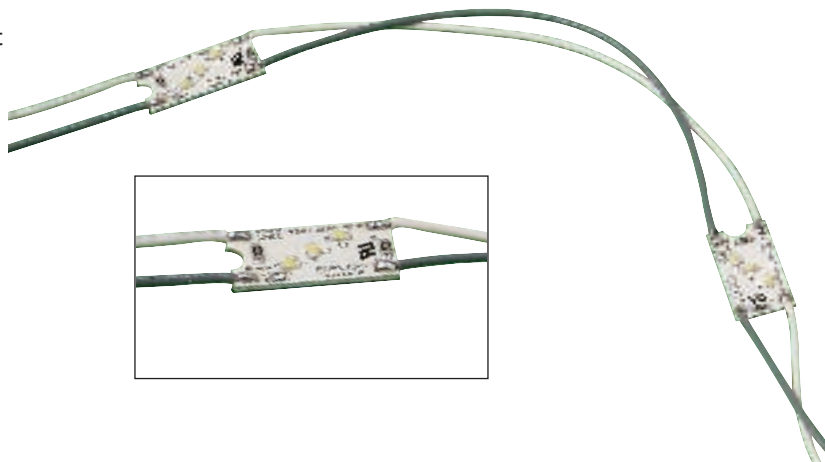

Input:	12 VDC nominal, 12.3VDC maximum
Dimensions:	0.50" x 1.0" (not including wires)
Spacing:	2 modules per foot, 6" on centers
Mounting:	Supplied VHB tape on back of module Built-in notch can be used to attach with plastic screw or rivet
Power per module:	2.5 watts
Warranty:	5 years

ITEM NO.	COLOR	ESTIMATED LIFE (HOURS)
PERM-777-WHT	Cool White (6500K)	100,000

El Plato 747 Series

El Plato™ is a complete system which is ideal for illuminated face, reverse/halo or cove lighting. The extra long module board is ideal for large channel letters and long run coves. EL Plato operates at a safe 12VDC for compatibility with other Permlight LED systems.

- Equivalent light output to a 60mA neon
- Ideal for illuminated channel letters
- Weather resistant conformal coating
- Simple "peel & stick" installation
- Available in multiple colors

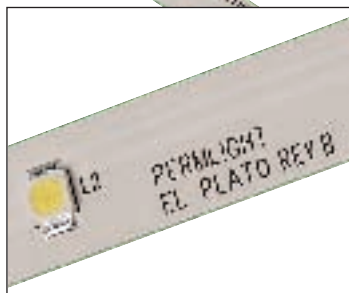

Input:	12 VDC nominal, 12.3VDC maximum
Dimensions:	0.60" x 8.5" (not including wires)
Spacing:	17.5" on centers
Mounting:	Supplied VHB tape on back of module
Power per module:	Ruby Red: 2.5 All other colors: 3.5 watts
Warranty:	5 years

ITEM NO.	COLOR	ESTIMATED LIFE (HOURS)
PERM-747-RED	Ruby Red (630nm)	100,000
PERM-747-AMBER	Amber (590nm)	100,000
PERM-747-BLUE	Blue (470nm)	40,000
PERM-747-GREEN	Green (525nm)	40,000
PERM-747-WHT	Neon White (6500K)	40,000
PERM-747-WW	Warm White (2750K)	40,000

Power Supplies

PERMIGHI

60 Watt Power Supply

The 60-12DC series is an AC to DC power supply with a single primary input (AC) and single secondary output (DC) rated at 60 Watts. The secondary side has a maximum output of no more than 5.0 A and complies with all requirements by Underwriters Laboratories (UL) for a standard Class 2 power unit. With no minimum load requirement, the system is engineered to supply a constant 12 VDC output for optimum LED performance and includes safety features such as overload and short circuit protection to prevent damage to the power supply and LED's.

- 120 - 240 VAC input (AC)
- Output overload and short circuit protection
- Class 2 output power supply
- No minimum load requirement
- Integrated junction box
- Small footprint, easily fits into a channel raceway.
- Rated for Damp Location



ITEM NO.	INPUT VOLTAGE (VAC)	OUTPUT VOLTAGE (VDC)	TOTAL OUTPUT POWER
PERM-60-12DC	120 - 240	12	60 Watts

240 Watt Power Supply

The 250-12DC series is an AC to DC power supply with a single primary input (AC) and 4 independent secondary outputs (DC) rated at 60 Watts per channel (240 Watts total). Each channel has a maximum output of no more than 5.0 A and complies with all requirements by Underwriters Laboratories (UL) for a standard Class 2 power unit. With no minimum load requirement, the system is engineered to supply a constant 12 VDC output for optimum LED performance and includes safety features such as overload and short circuit protection to prevent damage to the power supply and LED's.

- Single line voltage input with 4 independent secondary channel outputs (60 Watts per channel)
- Available in 120, 220, and 277 VAC inputs
- Output overload and short circuit protection
- Class 2 output power supply
- No minimum load requirement
- Integrated junction box
- Rated for Damp Location

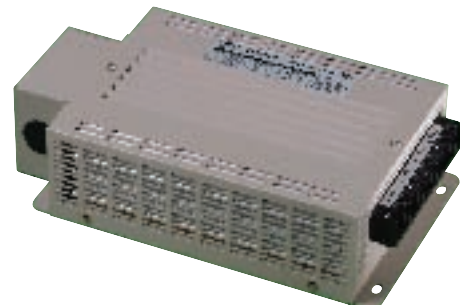

ITEM NO.	INPUT VOLTAGE (VAC)	OUTPUT VOLTAGE (VDC)	TOTAL OUTPUT POWER
PERM-250-12DC	120	12	240
250-12DC-220	240	12	240
250-12DC-277	277	12	240

Wire 14ga.

100' roll.

ITEM NO. PERM-WIRE

PERMIGHI

Square Super Flux Module

The NeonPro LED light module is developed for the special requirements of advertising market on the basis of the advantage of LED. It can work in high-power with low working voltage, safe and easy. It is a replacement of the traditional neon light.

NeonPro

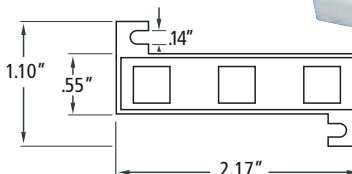
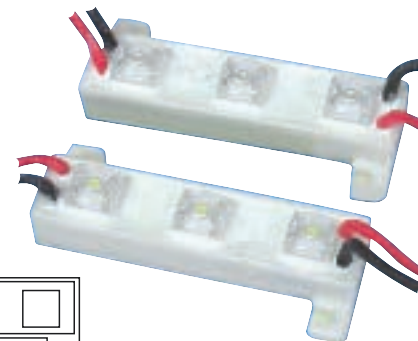

LED per Module:	3 pcs.
Input Voltage:	12VDC
Unit Watts:	Red, Yellow: 0.60 Blue, Green: 0.36
Viewing Angle:	130°
Module Size (LxWxH):	2.17" x 1.10" x 0.43"
Modules per Chain:	25

ITEM NO.	COLOR	WAVE LENGTH (nm)
NPLEDMS-R	Red	635
NPLEDMS-Y	Yellow	590
NPLEDMS-B	Blue	470
NPLEDMS-G	Green	525

CooChip™ LED Module

- Using innovative CooChip technology, the LED chip is attached and bonded directly to the aluminum PCB and heat-sink, resulting in ultra low heat resistance. CooChip™ RUNS COOL!
- Extended operating life at high ambient temperature.
- Wide angle, multi-LED design emits much softer, more even light compared to single LED solution.
- Excellent for channel letter, cabinet lighting or any other back lighting application.

NeonPro

LED per Module:	3 pcs.
Input Voltage:	12VDC
Unit Watts:	Red: 0.60
Viewing Angle:	130°
Module Size (LxWxH):	9mm x 30mm x 3.5mm
Modules per Chain:	50

ITEM NO.	COLOR	WAVE LENGTH (nm)
NPLEDMI-RED	Red	625

NeonPro

AC to DC Single Output Switching Power Supply



ITEM NO.	DESCRIPTION	INPUT VOLTAGE RANGE	INPUT CURRENT	OUTPUT VOLTAGE	OUTPUT WATTS	OVERALL DIMENSIONS (LxWxH)
NPLEDPS4012	Metal Case, UL/EMC	120/240	1.0A/0.5A max.	15Vdc max.	40	11.4" x 2.4" x 1.5
NPLEDPS6012	Metal Case, UL/EMC	120/240	1.2A/0.6A max.	15Vdc max.	60	13" x 2.4" x 1.5
NPLEDPS9012	Metal Case, UL/EMC	120/240	1.8A/1.0A max.	15Vdc max.	90	15" x 2.4" x 1.5



Allanson's StormTight RGB System merges our superior LED technology with advanced controllers that allow you to create mass color variations and customized program sequencing to maximize sign awareness in any environment.

ChromaLED StormTight RGB gives you:

- Exceptional Special Effects
- State of the art color switching & animation
- Reliable Indoor & Outdoor applications
- Customized Programming with over 300 watts output

LED per Module:	3 red, 3 green & 3 blue
Input Voltage:	12VDC
Unit Watts:	1.08
Viewing Angle:	110°
Module Size (LxWxH):	1 5/8" x 1 5/8" x 3/16"
Modules per foot:	3
Modules per box:	28
Warranty:	3 years

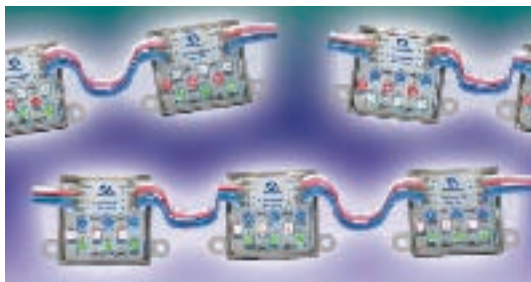

ITEM NO.	DESCRIPTION
ALED-ST-RGB	ALLANSON #ACLW-RGB StormTight RGB EA.

DC Power Supplies

ITEM NO.	INPUT VOLTAGE	INPUT FREQUENCY	INPUT CURRENT	OUTPUT VOLTAGE	POWER OUTPUT	OVERALL DIMENSIONS (LxWxH)
ALED-CV-121	120 VAC	50/60 Hz	0.14 Amps	12 VDC	12 Watts	6" x 1 3/4" x 1"
ALED-CV-125	120 VAC	50/60 Hz	1 Amps	12 VDC	60 Watts	7 5/8" x 3" x 1 1/2"
ALED-CV-12125	120 VAC	50/60 Hz	1.25 Amps	12 VDC	120 Watts	9 1/2" x 3" x 1 3/4"
ALED-CV-1212	120/240 VAC	50/60 Hz	1.25 Amps	12 VDC	150 Watts	7 3/4" x 4 1/4" x 1 3/8"
ALED-CV-1225	120/240 VAC	50/60 Hz	1.25 Amps	12 VDC	300 Watts	8 1/2" x 4 1/2" x 1 3/8"

Master Controller

ACL-MC

Operates at 12 volts DC, consumes less than 2 watts, and accepts signal input through an RS232 port, with data input indicator light.

ITEM NO. ALED-ACL-MC

Sub Controllers

ACL-SC30

Sub Controller watts. Operates at 12 VDC and consumes less than 1 watt. Weatherproof.

ITEM NO. ALED-ACL-SC30

ACL-SC60

Sub Controller 60 watts. Operates at 12VDC and provides 2x30 watts channels. Not remote.

ITEM NO. ALED-ACL-SC60

ACL-RSC60

Remote Sub Controller 60 watts. Operates at 12 VDC and consumes less than 1 watt.

ITEM NO. ALED-ACL-RSC60

ACL-SC600

Sub Controller 600 watts. Operates at 12 VDC, consumes less than 1 watt and provides 2x300 watts channels.

ITEM NO. ALED-ACL-SC600



www.sfsupplies.com



INDEX

DIGITAL MEDIA	5
SIGN VINYL	45
VINYL AND WRAP SUPPLIES	59
WIDE FORMAT EQUIPMENT	73
VINYL CUTTERS	87
ENGRAVERS	95
SOFTWARE	97
SUBSTRATES	105
BANNER	127
SIGN DISPLAY	139
TAPES & ADHESIVES	145
PAINT	153
NEON SUPPLIES & EQUIPMENT	167
TRANSFORMERS	207
LED SYSTEMS	229
LIGHTING & ELECTRIC	243
Ferromagnetic Sign Ballast.....	245-248
Electronic Sign Ballast.....	249-251
Fluorescent Fixtures & Lamps.....	252-256
Designer Fixtures.....	257-258
HID Lighting.....	259
Accessories.....	260
SIGN CONTROL	
Flashers.....	261-262
Chasers.....	262
Spellers.....	262
Time Clock.....	264
Photocontrol.....	264
Rotators.....	265
Outdoor Clocks.....	266
SIGN EXTRUSION	267
LETTER & ACCESSORIES	277
MOUNTING HARDWARE	281
EQUIPMENT & SHOP TOOLS	293

High - Output Fluorescent Sign Ballasts

- 800 mA output for High Output Fluorescent lamps, provides higher light output, increasing the brilliance of your electrical sign.
- Thermally protected class "P" ballasts, automatically turn off when the ballast is hot, thus extend the longevity of the ballasts.
- High power factor, 277 and 347 Volt models, reducing operation and installation costs.



Transformers are UL2161 Listed and CSA Approved.

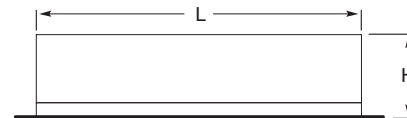
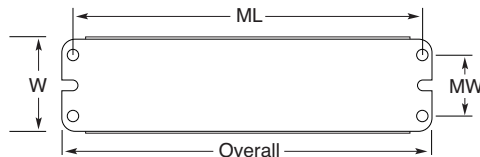

High Output, Rapid Start, 120 Volts, 60 Hertz

120 Volts		277 Volts		LAMP-FOOTAGE MIN - MAX	TOTAL LAMPS	INPUT WATTS	OPEN CIRCUIT VOLTS	DIMENSIONS IN INCHES					WT. LBS.	WIRING DIAGRAM*	
ITEM NO.	LINE AMP	ITEM NO.	LINE AMP					Overall	L	W	H	ML			MW
EA148	0.70	EA148277	0.33	2 - 4	1	65	330	11 3/4	11 1/8	3.188	2 3/8	11 1/8	2	11 3/4	1
EA224	0.70	EA224277	0.31	2 - 4	2,1	80	330	11 3/4	11 1/8	3.188	2 3/8	11 1/8	2	11 3/4	4
EA272	1.60	EA272277	0.69	4 - 12	2,1	190	475	11 3/4	11 1/8	3.188	2 3/8	11 1/8	2	11 3/4	4,3
EA296	2.00	EA296277	0.90	12 - 16	2	222	530	11 3/4	11 1/8	3.188	2 3/8	11 1/8	2	11 3/4	3
EA348	1.50	EA348277	0.66	6 - 12	3,2,1	162	530	11 3/4	11 1/8	3.188	2 3/8	11 1/8	2	11 3/4	9,8,7
EA372	2.00	EA372277	0.97	12 - 18	3,2	250	720	11 3/4	11 1/8	3.188	2 3/8	11 1/8	2	11 3/4	8,7
EA396	2.70	EA396277	1.20	18 - 24	3,2	298	720	11 3/4	11 1/8	3.188	2 3/8	11 1/8	2	11 3/4	8,7
EA448	1.90	EA448277	0.86	8 - 18	4,3,2	235	575	11 3/4	11 1/8	3.188	2 3/8	11 1/8	2	11 3/4	12,11,10
EA472	2.80	EA472277	1.18	16 - 24	4,3,2	312	720	11 3/4	11 1/8	3.188	2 3/8	11 1/8	2	11 3/4	12,11,10
EA496	3.30	EA496277	1.43	24 - 32	4,3,2	375	1000	16 1/2	15 1/2	3.188	2 3/8	15 1/2	2	17 1/4	11,10
EA4120	3.80	EA4120277	1.57	20 - 40	4,3,2	455	2 x 800	16 1/2	15 1/2	3.188	2 3/8	15 1/2	2	17 1/4	12,11,10
EA572	3.20	EA572277	1.43	20 - 30	5,4	365	982	16 1/2	15 1/2	3.188	2 3/8	15 1/2	2	17 1/4	14,13
EA648	2.80	EA648277	1.22	8 - 24	6,5,4	320	850	16 1/2	15 1/2	3.188	2 3/8	15 1/2	2	17 1/4	17,16,15
EA672	4.20	EA672277	1.79	24 - 36	6,5,4	470	1000	16 1/2	15 1/2	3.188	2 3/8	15 1/2	2	17 1/4	17,16,15
EA696	4.30	EA696277	1.76	30 - 48	6,5,4	510	2 x 790	16 1/2	15 1/2	3.188	2 3/8	15 1/2	2	17 1/4	17,16,15

*See wiring diagrams on page 248

Sign Ballast

High - Output Fluorescent Sign Ballasts



- Provide ultra-reliable, low temperature starting (as low as -20°F)
- Support 1 to 6 lamps
- Ideal for rugged outdoor sign cabinet applications
- UL Class P thermally protected, Type 2 Outdoor, HL

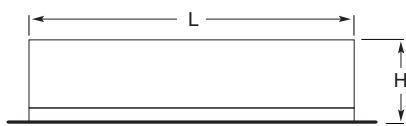

High Output 800mA RS Lamps - 120 Volts - 60 Hz

120 Volts											
ITEM NO.	LAMP-FOOTAGE MIN - MAX	TOTAL LAMPS	LINE	INPUT WATTS	OPEN CIRCUIT VOLTS	DIMENSIONS (Inches)					WT. LBS.
						L	OVERALL	ML	H	W	
EM148	2' - 5'4"	1	0.55	65	400	10 ³⁷ / ₆₄	11 ⁴⁵ / ₆₄	11 ⁹ / ₆₄	1 ³ / ₄	3 ³ / ₁₆	8
EM248	3' - 8'	2,1	0.90	105	400	10 ³⁷ / ₆₄	11 ⁴⁵ / ₆₄	11 ⁹ / ₆₄	1 ³ / ₄	3 ³ / ₁₆	8
EM272	4' - 12'	2,1	1.35	160	500	10 ³⁷ / ₆₄	11 ⁴⁵ / ₆₄	11 ⁹ / ₆₄	1 ³ / ₄	3 ³ / ₁₆	8
EM296	12' - 16'	2,1	1.80	210	500	10 ³⁷ / ₆₄	11 ⁴⁵ / ₆₄	11 ⁹ / ₆₄	2 ⁴³ / ₆₄	3 ³ / ₁₆	11
EM348	4' - 12'	3,2,1	1.35	160	500	10 ³⁷ / ₆₄	11 ⁴⁵ / ₆₄	11 ⁹ / ₆₄	1 ³ / ₄	3 ³ / ₁₆	8
EM372	12' - 18'	3,2	2.00	240	590	10 ³⁷ / ₆₄	11 ⁴⁵ / ₆₄	11 ⁹ / ₆₄	2 ⁴³ / ₆₄	3 ³ / ₁₆	12
EM396	10' - 24'	3,2,1	2.70	325	720	13 ³ / ₁₆	14 ⁵ / ₁₆	13 ³ / ₄	2 ⁴³ / ₆₄	3 ³ / ₁₆	14
EM3120	16' - 30'	3,2	3.50	395	885	15 ⁹ / ₁₆	16 ¹¹ / ₁₆	16 ¹ / ₈	2 ⁴³ / ₆₄	3 ³ / ₁₆	16
EM448	8' - 16'	4,3,2,1	1.90	220	590	10 ³⁷ / ₆₄	11 ⁴⁵ / ₆₄	11 ⁹ / ₆₄	2 ⁴³ / ₆₄	3 ³ / ₁₆	12
EM464	10' - 22'	4,3,2,1	2.40	285	680	13 ³ / ₁₆	14 ⁵ / ₁₆	13 ³ / ₄	2 ⁴³ / ₆₄	3 ³ / ₁₆	14
EM472	10' - 24'	4,3,2,1	2.70	325	720	13 ³ / ₁₆	14 ⁵ / ₁₆	13 ³ / ₄	2 ⁴³ / ₆₄	3 ³ / ₁₆	14
EM484	16' - 28'	4,3,2	3.50	420	950	15 ⁹ / ₁₆	16 ¹¹ / ₁₆	16 ¹ / ₈	2 ⁴³ / ₆₄	3 ³ / ₁₆	16
EM496	16' - 32'	4,3,2	3.50	420	950	15 ⁹ / ₁₆	16 ¹¹ / ₁₆	16 ¹ / ₈	2 ⁴³ / ₆₄	3 ³ / ₁₆	16
EM4120	20' - 40'	4,3,2	4.40	520	720	15 ⁹ / ₁₆	16 ¹¹ / ₁₆	16 ¹ / ₈	2 ⁴³ / ₆₄	3 ³ / ₁₆	18
EM648	10' - 26'	6,5,4	3.00	340	825	15 ⁹ / ₁₆	16 ¹¹ / ₁₆	16 ¹ / ₈	2 ⁴³ / ₆₄	3 ³ / ₁₆	16
EM672	20' - 36'	6,5,4	4.00	480	720	15 ⁹ / ₁₆	16 ¹¹ / ₁₆	16 ¹ / ₈	2 ⁴³ / ₆₄	3 ³ / ₁₆	18
EM696	20' - 48'	6,5,4	5.00	600	720	15 ⁹ / ₁₆	16 ¹¹ / ₁₆	16 ¹ / ₈	2 ⁴³ / ₆₄	3 ³ / ₁₆	18



Wiring Diagrams for Allanson Sign Ballast

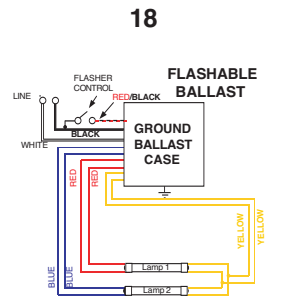
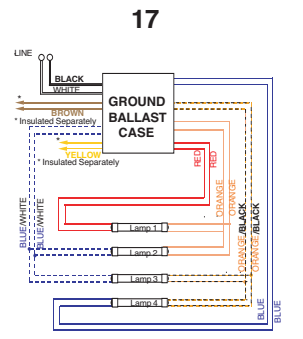
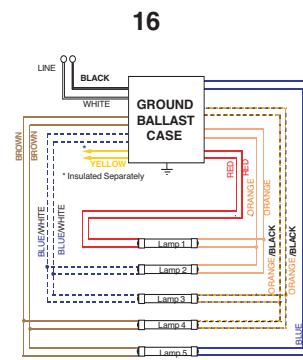
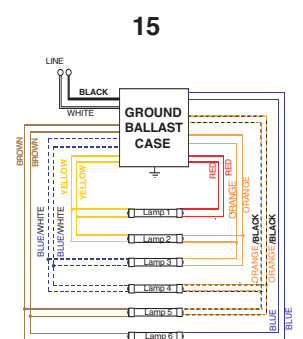
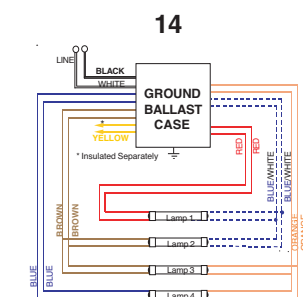
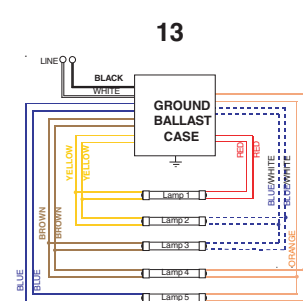
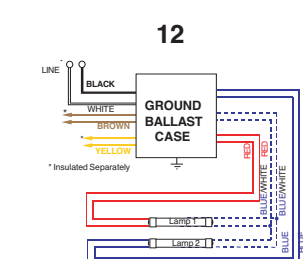
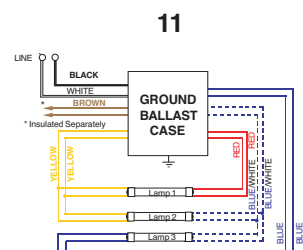
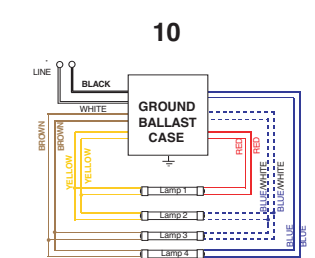
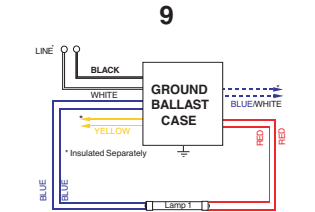
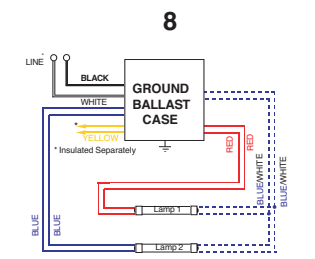
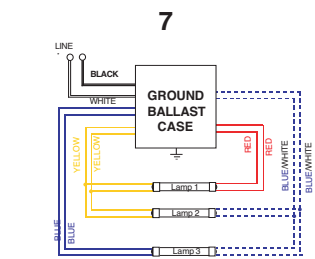
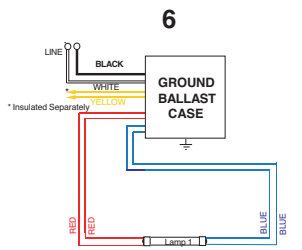
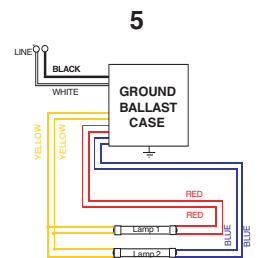
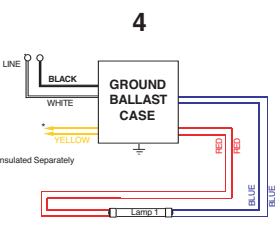
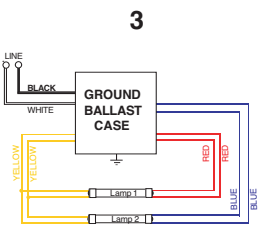
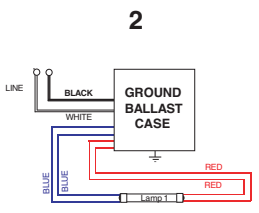
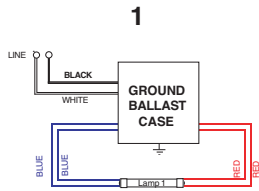

RSS Rapid Start High Output Fluorescent Ballasts

For T-8 and T-12 High Output Lamps 2' to 10' lamp operation

Allanson's RSS ballasts combine solid-state technology with magnetic ballast wiring to ensure:



- Five RSS ballasts replace 15 existing models
- Rapid cold-weather starts
- Increased lamp life
- Retrofitability with standard ballasts
- Easy field replacement
- Energy savings

This allows for less inventory, more flexibility and increased savings. The new smaller profile allows for greater adaptability for low profile signage and menu board applications.



High Output Rapid Start T8/T12 Lamps, 120V, 50/60 Hz

120 Volts							
ITEM NO.	TOTAL LAMPS	LINE	OPEN CIRCUIT VOLTAGE	LAMP-FOOTAGE MIN - MAX	DIMENSIONS (Inches)		
					L	W	H
EARSS196AT	1- F96T8HO/86W	1.00	825	2' - 8'	9½"	2 ¹¹ / ₃₂ "	1 ¹¹ / ₁₆ "
	1- F96T12HO/110W	0.85					
	1- F72T8HO/65W	0.75					
	1- F24T12HO/37W	0.32					
EARSS296AT	2- F96T12HO/110W	1.60	950	4'-16' (T12) 4'-12' (T8)	11¾"	2 ⁵ / ₃₂ "	1½"
	2- F72T8HO/65W	1.45					
	1- F120T12HO/135W	1.10					
	1- F96T8HO/86W	1.05					
	1- F96T12HO/110W	0.90					
EARSS396AT	3- F96T12HO/110W	2.20	950	8'-24' (T12) 8'-18' (T8)	11¾"	3 ³ / ₁₆ "	1 ²⁵ / ₃₂ "
	3- F72T8HO/65W	2.15					
	2- F120T12HO/135W	2.00					
	2- F96T8HO/86W	1.90					
	2- F96T12HO/110W	1.65					
	2- F72T8HO/65W	1.60					
EARSS496AT	4- F96T12HO/110W	3.20	950	8'-32' (T12) 8'-24' (T8)	14 ⁷ / ₁₆ "	3 ³ / ₁₆ "	2 ⁵ / ₈ "
	4- F72T8HO/65W	2.55					
	3- F96T12HO/110W	2.30					
	2- F120T12HO/135W	2.30					
	2- F96T8HO/86W	2.20					
	2- F96T12HO/110W	1.75					
EARSS696AT	6- F96T12HO/110W	4.15	950	24'-48' (T12) 18'-36' (T8)	16½"	3 ³ / ₁₆ "	2 ⁵ / ₈ "
	6- F72T8HO/65W	4.10					
	4- F120T12HO/135W	3.96					
	4- F96T8HO/86W	3.80					
	5- F96T12HO/110W	3.65					
	4- F96T12HO/110W	3.20					

Sign Ballast

Electronic Sign Ballasts



Universal input voltage

- Installer-friendly
- Reduces inventory costs
- Ideal for international projects

Parallel lamp operation

- When one lamp fails, other lamps remain lit keeping the sign illuminated
- Provides for ballast application flexibility

Simplified wiring

- Industry-standard red and blue leads simplify wire management
- Fewer connections for quicker installation

Multiple lamp use

- Operate multiple lamps in series on one circuit
- Improved sign lighting flexibility

Four units cover all applications from 2 to 48 feet in total length

- Three models operate T12HO lamps up to eight-feet
- One 4-lamp model specifically designed for 9-10 foot amps
- Cold temperature starting down to -20° F
- Instant start operation
- Maximizes energy savings—up to an additional 25% energy savings over standard magnetic sign ballasts
- UL "Type-2" cans for improved durability and resistance to rust
 - UL "HL" rated for hazardous locations
 - Lightweight for easy installation
 - cULus listed



T12/T8 Rapid Start High Output Lamps - 108 to 305 Volts - 50/60 Hz

120 Volts		LAMP-FOOTAGE MIN - MAX	TOTAL LAMPS	INPUT VOLTAGE	INPUT WATTS	LINE	DIMENSIONS (Inches)					WT. LBS.	WIRING DIAGRAM
ITEM NO.							L	OVERALL	ML	H	W		
EMESB216-12 <small>For T12 lamps up to 8' per lamp or T8 lamps up to 6' per lamp</small>	2'-16' (T12)	2,1		120	160	1.3	15 ⁹ / ₁₆	16 ¹¹ / ₁₆	16 ¹ / ₈	2 ⁴³ / ₆₄	3 ³ / ₁₆	8	1, 4
				2'-12' (T8)	277	155							
EMESB432-14 <small>For T12 lamps up to 8' per lamp or T8 lamps up to 6' per lamp</small>	4'-32' (T12)	4,3,2,1		120	307	2.6	15 ⁹ / ₁₆	16 ¹¹ / ₁₆	16 ¹ / ₈	2 ⁴³ / ₆₄	3 ³ / ₁₆	9	2, 4
				4'-24' (T8)	277	294							
EMESB848-46 <small>For T12 lamps up to 8' per lamp or T8 lamps up to 6' per lamp</small>	8'-48' (T12)	6,5,4		120	476	4.0	15 ⁹ / ₁₆	16 ¹¹ / ₁₆	16 ¹ / ₈	2 ⁴³ / ₆₄	3 ³ / ₁₆	10	3, 4
				8'-36' (T8)	277	458							
EMESB1040-14 <small>For T12 lamps up to 10' per lamp or T8 lamps up to 8' per lamp</small>	10'-40' (T12)	4,3,2,1		120	341	4.0	15 ⁹ / ₁₆	16 ¹¹ / ₁₆	16 ¹ / ₈	2 ⁴³ / ₆₄	3 ³ / ₁₆	10	2, 4
				8'-32' (T8)	277	331							

Wiring Diagram

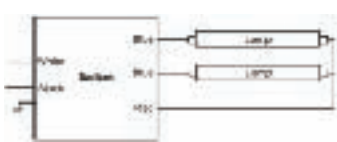

(1) 2-lamp wiring



(2) 4-lamp wiring



(3) 6-lamp wiring

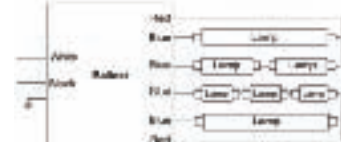

(4) Multiple lamp use*

*Multiple lamp use varies by model, please see complete specification information

Ballast Trouble Shooting Procedures

Primary Current:

Place clamp around the black primary hot lead. This reading should be at or below the rating of the ballast as indicated on the label. If the total combined footage does not meet the maximum of the ballast's limit, then this reading will be less than stated on the label. If this reading exceeds the rating, then there is either a short in the wiring or the wiring is incorrect. Double-check the actual wiring with the wiring diagram on the label, and look for any wires that may be shorted to ground or one another.

Primary Voltage:

Take the voltage measurement across the black and white wire. The voltage should be +/- 5% of nominal rating. Any deviation from this will cause premature failure of the ballast. If this voltage is low, attempt to locate the reason; make sure that the wire used to supply the circuit is of sufficient size for the distance from the panel and the rated load. Check the voltage at different points in the primary run to find out where the problem may exist.

Filament Voltage:

Measure the voltage in the socket from pin to pin. The reading here should be between 3.5 VAC to 4.5 VAC.

If the voltage reading is below 3.5:

- Check for low primary input voltage.
- Check for shorted filament wires within the sign.
- Possibly a damaged ballast.

If the voltage reading is above 4.5 volts:

- Check for high primary input voltage.
- Possibly a damaged ballast.

Filament Current:

Using a clamp-on amp probe, measure the current in each wire with the exception of the black and white ones. The normal reading will be between .5 AMPS to 2 AMPS. A reading larger than this would indicate incorrect wiring, or a short circuit.

If the current reading is below 0.5 amps:

- Open lamp filament (defective lamp)
- Improper filament wiring connection causing an open circuit.
- Check for low primary input voltage.
- Possibly a damaged or defective ballast.

If the current reading is above 2 amps:

- External short in the filament wiring.
- Incorrect lamp or defective lamp filament.
- Check for high primary input voltage.
- Possibly a damaged or defective ballast.

Lamp Filament Resistance:

With standard test probes, measure resistance between the two pins at the end of the lamp. This test should be performed for both ends of the lamp, and on each lamp in the circuit. The expected resistance should be approximately (.5 to 1.2 ohm).

- Resistance greater than this would indicate an open lamp filament and the lamp should be replaced.
- Resistance less than this would indicate a shorted filament and the lamp should be replaced.

Open Circuit Voltage:

Take the voltage reading across the blue and red wire. The reading should be between 300 and 1000 volts depending on the ballast model. On Allanson's 696 and 4120, the readings should be taken between the blue/white and red as well as the blue/white and blue, because these are dual circuit ballasts. See the ballast label for specific Open Circuit Voltage rating.

If the OCV reading is below the rating on label:

- Check for low primary input voltage.
- Possibly a damaged ballast.

If the OCV reading is above the rating on the label:

- Check for high primary input voltage.
- Possibly a damaged

Lamp Current:

Place clamp-on amp probe around the lamp while it is lit. Reading should be between 400 and 800 MA. Smaller ballasts should be at the high end of the range and larger ballasts should be at the lower end of the range.

Should the current reading is below 400 MA:

- Total lamp footage exceeds ballast rating.
- Defective lamp (s).
- Check for low primary input voltage.
- Possibly a damaged ballast.

Should the current reading is above 800 MA:

- Total lamp footage is below ballast rating.
- Defective lamp (s).
- Check for high primary input voltage.
- Possibly a damaged ballast.

Is there a Ground Plane ?:

Ballasts are designed to be used with starter strips. They assist the ballast at time of lamp startup in colder weather, or when a ballast is running at maximum load. On single face signs where the lamps are in close proximity to the metallic sign back, strips may not be needed. The only time in trouble shooting where this is an issue, is when lamps only flicker at startup, or take a very long time to come to full brightness.

Fluorescent Fixtures

Awning Fixtures



Outdoor Damp Location

All fixtures are steel die formed with contour ribs for maximum strength. A combination end/joiner plate for row mounting. Snap-on wireway reflector covers. Climatized baked white enamel finish. Completely wired with internal type 120 degree outdoor ballasts for damp location.

- 120 volt - 60 hertz.
- Sizes 48", 72" and 96"
- Also available in 277 volts and 50 hertz
- UL listed.
- Available with electronic ballast for T8 & T12 H.O. Lamps also with aluminum body



ITEM #	DESCRIPTION	SIZE
EL248	2 Lamp Fixture	48"
EL272	2 Lamp Fixture	72"
EL296	2 Lamp Fixture	96"

Eggcrates

White & Black Eggcrates

1/2" x 1/2" x 3/8"

Provides a subtle luminous quality, well ordered architectural appearance, excellent visual comfort and lighting efficiency. The open cell design permits free circulation of air which results in lower operating temperatures, thus increasing ballast life and improving lamp performance. Interlocking step trim design permits panels to be butted together without a noticeable joint

Applications:

- Fluorescent Lighting Fixture Diffusers
- Under Awning Lighting Diffusers

ITEM NO.	SIZE	COLOR	BOX
AWEC	2' x 4'	White	15
AWECB	2' x 4'	Black	15

Also available in 1' x 1' and 2' x 2' upon request

Gold & Silver Eggcrates

3/4" x 3/4" x 3/8"

The ideal solution where a small cell shallow depth parabolic louver and greater lighting efficiency is required. These louvers are easily installed in lighted ceiling, lighting fixture or retrofit installations. The louver's 28° shielding angle gives excellent lamp obscuration.

ITEM NO.	SIZE	COLOR	BOX
AWECG	2' x 4'	Gold	15
AWECS	2' x 4'	Silver	15

For Wet and Damp Locations

These Gasketed Enclosures are totally dust and moisture resistant. The enclosure is constructed of a fiberglass upper body and an acrylic, crepe pattern diffuser securely positioned by a permanent poured in place sealing gasket. The diffuser and upper components are locked together by retaining latches, assuring a secure, tight seal.

The Gasketed Enclosure is a U. L. recognized component, certified by the NSF international and has the CSA component acceptance mark.

Gasketed enclosure will accept 1 or 2 lamp, rapid start, high output or slim line type fluorescent fixtures.

ITEM #	DESCRIPTION
EWPC4	48" Hardware Kit (6/latches, 2/end plugs, 2/nuts)
EWPC4	48" Clear Difuser only
EWPC4	48" Waterproof Enclosure (Housing Only)
EWPC8	96" Hardware Kit (10/latches, 2/end plugs, 4/nuts)
EWPC8	96" Clear Difuser only
EWPC8	96" Waterproof Enclosure (Housing only)

Gasketed Enclosures



Sure-Seal™ Gasketing

A continuous poured gasketing without start or end points. A sure, positive seal that stays securely in place.

Structurally Rigid Fiberglass Body

Fiberglass is reinforced polyester and self-extinguishing (ASTM D635-74). This type of construction does not allow the body to flax during handling and installation.

Gasketed Diffuser Retention Slot

The gasketed inverted U-slot provides a positive continuous seal between body and diffuser.

Brass Fixture Mounting Stud

The fixture studs are integrally molded into the body to facilitate lighting fixture installation.

High Impact Acrylic/dr Diffuser

Internal crepe pattern allows a smooth exterior surface for ease of cleaning.

Diffuser

The diffuser flange fits snugly into the gasketed retention slot forming a continuous seal.

Replacement Diffusers

Extra LCW white latches and FEPW white end plugs are available upon request. Polycarbonate latches and tamper proof latches are also available. Diffusers are available (opal, prismatic, polycarbonate, 100% DR). Contact A.L.P. requirements.

Fluorescent Fixtures

LITE•O•LINE Fluorescent Sign Light

All weather lighting for signs and buildings

Ideal for illuminating billboards, store fronts, building facades and perimeters. The heavy duty weather resistant design is UL & CUL certified for damp and wet locations.

Available in 4, 6 or 8 foot versions, with one or two lamps. The aluminum housing incorporates an internal reflector for increased light output and efficiency. A splice box at each end permits 360° rotary adjustments.

Suitable for continuous row mounting.

- Anodized aluminum housing
- Internal reflector with bake enamel finish
- Clear extruded acrylic diffuser with unique locking feature
- Prewired sockets for either HO/VHO or Bi-pin fluorescent lamps
- White power coat available

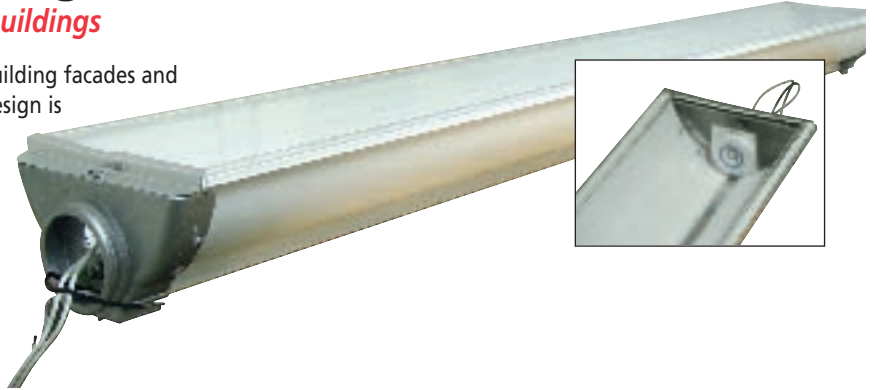

Shielded 1 Lamp Units - 800ma

ITEM NO.	SIZE	LAMPS
ELOL148	4'	1-F48T12HO
ELOL172	6'	1-F72T12HO
ELOL196	8'	1-F96T12HO

Shielded 2 Lamp Units - 800ma

ITEM NO.	SIZE	LAMPS
ELOL248	4'	2-F48T12HO
ELOL272	6'	2-F72T12HO
ELOL296	8'	2-F96T12HO

Ballast for LITE•O•LINE

Weatherproof

ITEM NO.	MFG. PART #	DESCRIPTION
EARC2S110FO	#RC-2S110-FO	H.O. Ballast For 2 F72", F96"
EARC2S85FO	#RC-2S85-FO	H.O. Ballast For 1 or 2 F48", F72" or for 1 F96"
EARC2S200FO	#RC-2S200-FO	V.H.O. Ballast For 2 F72", F96"
EARC2S102FO	#RC-2S102-FO	V.H.O. Ballast For 1 or 2 F48" or for 1 F72", F96"



PG9 Spring Sockets

Completely isolates the face of the socket from ground. No metal clips means no corrosion or electrical grounding. UL listed and CSA certified for outdoor use in enclosed signs and fixtures.

Rating: 660 watts, dual rated 600V or 1000V.

20 per box.

ITEM NO. ESHO731732



H/O Lamps

Tubular Fluorescent Lamps

High Output T12 Lamps

With the highest lumens output and longest life in its respective T12 category, these best-performing lamps are ideal applications where maximum light levels and longer life are crucial.



ITEM NO.	LENGTH	COLOR	CASE QTY
EL18	18"	Cool White	24
EL18D	18"	Daylight	24
EL24	24"	Cool White	24
EL24D	24"	Daylight	24
EL30	30"	Cool White	24
EL30D	30"	Daylight	24
EL36	36"	Cool White	24
EL36D	36"	Daylight	24
EL42	42"	Cool White	24
EL42D	42"	Daylight	24
EL48	48"	Cool White	15
EL48D	48"	Daylight	15
EL60	60"	Cool White	15
EL60D	60"	Daylight	15
EL64	64"	Cool White	15
EL64D	64"	Daylight	15
EL72	72"	Cool White	15
EL72D	72"	Daylight	15
EL84	84"	Cool White	15
EL84D	84"	Daylight	15
EL96	96"	Cool White	15
EL96D	96"	Daylight	15

High Output T12 Big Boy™ Cost-Saving Length

The right time to use a Big Boy is any time you can avoid using two shorter lamps of equal length. By reducing the number of lamp ends (lumen losses) more light per-foot is achieved without unsightly center raceway shadows and with reduced labor and material costs: fewer ballasts, fewer sockets, and much less wiring.



ITEM NO.	LENGTH	COLOR	CASE QTY
EL108	F108"	Cool White	12
EL108D	F108"	Daylight	12
EL117	F117"	Cool White	12
EL117D	F117"	Daylight	12
EL120	F120"	Cool White	12
EL120D	F120"	Daylight	12

Very High Output T12 Lamps

ITEM NO.	LENGTH	COLOR	CASE QTY
EL48VHO	48"	Cool White	30
EL72VHO	72"	Cool White	15
EL96VHO	96"	Cool White	15

High Output T8 Lamps

Ideal for any lighting application requiring great light levels & longer life.



ITEM NO.	LENGTH	COLOR	CASE QTY
ELF48T8841HO	48"	TL841	24
ELF96T8841HO	96"	TL841	24
ELF60T8TL841HO	60"	TL841	24
ELF72T8TL841HO	72"	TL841	24

U-Lamps

Engineered to precise manufacturing standards, these lamps will deliver the long lasting results that your sign program demands.



Masonlite Long Lamps are ISO 9001 registered and certified.

FTU6 Cool White

ITEM NO.	LAMP TYPE	BENT LENGTH
ELFTU624CWHO	FTU6-24T12CW/HO	12"
ELFTU636CWHO	FTU6-36T12CW/HO	18"
ELFTU648CWHO	FTU6-48T12CW/HO	24"
ELFTU660CWHO	FTU6-60T12CW/HO	30"
ELFTU672CWHO	FTU6-72T12CW/HO	36"
ELFTU684CWHO	FTU6-84T12CW/HO	42"
ELFTU696CWHO	FTU6-96T12CW/HO	48"
ELFTU6120CWHO	FTU6-120T12CW/HO	60"

FTU6 Daylight

ELFTU624DLHO	FTU6-24T12DL/HO	12"
ELFTU636DLHO	FTU6-36T12DL/HO	18"
ELFTU648DLHO	FTU6-48T12DL/HO	24"
ELFTU660DLHO	FTU6-60T12DL/HO	30"
ELFTU672DLHO	FTU6-72T12DL/HO	36"
ELFTU684DLHO	FTU6-84T12DL/HO	42"
ELFTU696DLHO	FTU6-96T12DL/HO	48"
ELFTU6120DLHO	FTU6-120T12DL/HO	60"

FTU9 Cool White

ITEM NO.	LAMP TYPE	BENT LENGTH
ELFTU936CWHO	FTU9-36T12CW/HO	18"
ELFTU948CWHO	FTU9-48T12CW/HO	24"
ELFTU960CWHO	FTU9-60T12CW/HO	30"
ELFTU972CWHO	FTU9-72T12CW/HO	36"
ELFTU984CWHO	FTU9-84T12CW/HO	42"
ELFTU996CWHO	FTU9-96T12CW/HO	48"
ELFTU9120CWHO	FTU9-120T12CW/HO	60"

FTU9 Daylight

ELFTU936DLHO	FTU9-36T12DL/HO	18"
ELFTU948DLHO	FTU9-48T12DL/HO	24"
ELFTU960DLHO	FTU9-60T12DL/HO	30"
ELFTU972DLHO	FTU9-72T12DL/HO	36"
ELFTU984DLHO	FTU9-84T12DL/HO	42"
ELFTU996DLHO	FTU9-96T12DL/HO	48"
ELFTU9120DLHO	FTU9-120T12DL/HO	60"

All U-Lamps are available as special order only.

Indoor / Sign bulbs

Slimline Fixture 2-96" 120v

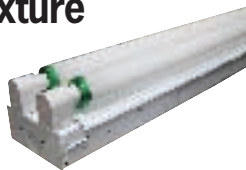

ITEM NO. EL296IN

Slimline Indoor Ballast



ITEM NO.	DESCRIPTION
EA248IN	For 48" lamps
EA296IN	For 96" lamps

Slimline Indoor T12 Lamps



ITEM NO.	LENGTH	COLOR	CASE QTY
EL48INCW	48"	Cool White	30
EL48INDL	48"	Daylight	30
EL96INCW	96"	Cool White	15
EL96INDL	96"	Daylight	15

Slimline Lampholder for all Slimline Lamps

Sockets for 8' lamps



ITEM NO.

ITEM NO.

ITEM NO.	DESCRIPTION
EDI-FL314W	Fixed End
EDI-FL315W	Spring End

Bi-Pin Lampholder

Pressure Lock

Single indoor
4' socket #326 W-2



ITEM NO. ESI4

Candelabra Base Bulb

ITEM NO.	COLOR
EC77WW	White
EC77CL	Clear



Sign and Scoreboard Lampholder

- Insulation displacement terminals for stranded wire.
- Lay in wire channels, 1/4 turn twist top speeds installation.



- One piece terminals and contacts. No rivets or eyelets to loosen due to heat.
- Snap-in mounting.
- Keyed spring washer prevents rotation of socket after installation.

ITEM NO.	BASE	WIRE RANGE
EEG	Medium	For #18 to #12
EEGS	Candelabra	For #20 to #18

To create knockouts for sockets, use an Eagle Socket Punch found on page 296

11S14 Sign Bulbs



ITEM NO.	COLOR	ITEM NO.	COLOR
E11S14CL	Clear	E11S14B	Blue
E11S14FR	Frosted	E11S14G	Green
E11S14W	White	E11S14OR	Orange
E11S14Y	Yellow	E11S14R	Red

Protect-A-Lamp For T12 Lamps, 96"

Tube Guards

Tube Guards are an efficient and economical solution in problem areas where lamp breakage would be hazardous to personnel, product or equipment. Tube Guards provide exposed lamps protection against dirt, dust, bugs and flying insects.

End Caps

End caps are made of a snug fitting heat resistant polypropylene plastic. The caps will hold the lamps in place even if broken and will prevent the tubes from falling.

Available colors: clear, red, green, blue, pink, gold, yellow and clear-UVA-7 (ultraviolet filtering).

Also available in different sizes and for T8 lamps

Meets safety standards required by OSHA National Electric code, U.S. Dept. of Agriculture Food and Drug



ITEM NO.	COLOR
EPAL96C	Clear
EPAL96R	Red
EPAL96GR	Green
EPAL96B	Blue
EPAL96P	Pink
EPAL96GA	Gold
EPAL96Y	Yellow
EPAL96CUVA	Clear-UVA

LED Bulb

SYLVANIA



ITEM NO.	DESCRIPTION	COLOR
ELEDS14CL	LED/S14/TW/1	#72231 Clear
ELEDS14TR	LED/S14/TR/1	#72232 Transparent Red
ELEDS14TG	LED/S14/TG/1	#72233 Transparent Green
ELEDS14TB	LED/S14/TB/1	#72234 Transparent Blue
ELEDS14TYA	LED/S14/TYA/1	#72235 Transparent Amber
ELEDS14FW	LED/S14/W/1	#72230 Frosted White
ELEDS14FB	LED/S14/B/1	#72237 Frosted Blue
ELEDS14FA	LED/S14/YA/1	#72238 Frosted Amber/Yellow
ELEDS14FR	LED/S14/R/1	#72264 Frosted Red
ELEDS1430G	S14/30LED/G	#72090 Green
ELEDS1430B	S14/30LED/B	#72091 Blue
ELEDS1430R	S14/30LED/R	#72092 Red
ELEDS1430Y	S14/30LED/Y	#72093 Yellow
ELEDS1430RGB	S14/30LED/RGB	#72094 R,G,B (Changing)

Sockets

PG9 Spring Sockets*for 800 and 1500 mA Lamps*

Completely isolates the face of the socket from ground. No metal clips means no corrosion or electrical grounding. UL listed and CSA certified for outdoor use in enclosed signs and fixtures. Rating: 660 watts, dual rated 600V or 1000V. 20 per box.

ITEM NO. ESHO731732

To create knockouts for sockets, use a "D" Socket Punch found on page 296

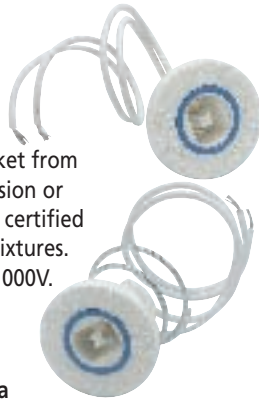
**Tombstone Sockets***for 800 and 1500 mA Lamps*

UL listed and CSA certified for outdoor use in enclosed signs and fixtures. Rating: 660 watts, dual rated 600V or 1000V. 20per box

ITEM NO. ESHO782783**HO Fixture Socket****#FL707-W Fixed End****ITEM NO.** EDI-FL707W**#FL708-W Spring End****ITEM NO.** EDI-FL708W**Ceramic Sockets****Front Mount Socket**

Medium base one-piece keyless incandescent unglazed porcelain lampholder. Front mount, single circuit back wired. 660W 600Volt.

ITEM NO. EPS**Porcelain Mogul Base***for High Pressure Sodium Lamps*

Mogul base one-piece keyless, HID, glazed porcelain lampholder, HPS up to 1000W, single circuit back wired, 5KV-pulse rated.

ITEM NO. EHPS-SOCKET-MOG**Conduit Boxes****T11 Electric Conduit Box**

- Outdoor weatherproof
- 4 $\frac{1}{16}$ " x 2 $\frac{1}{16}$ " x 2" with threaded outlets
- Closure plugs, ground screws and mounting lugs included
- 3 $\frac{1}{2}$ " outlet, UL Listed

ITEM NO. ECC**T11 Electric Cover with Switch**

- Outdoor Weatherproof
- Gasket and screws included
- 15A/S.P., UL Listed

ITEM NO. ECWS**T11 Electric Cover**

- Outdoor weatherproof
- 4 $\frac{1}{16}$ " x 2 $\frac{1}{16}$ " stamped Aluminum
- Gaskets and screws included
- UL Listed

ITEM NO. ECO

Gooseneck Designer Fixtures

Authentic Abolite offers a full line of strikingly beautiful and dependably efficient RLM and designer fixtures for indoor and outdoor lighting applications.

This comprehensive offering combines creativity with energy and maintenance saving advantages to complement both traditional and progressive design schemes in restaurants, hotels, airport concourse areas, retail locations, offices and other public spaces.

All Abolite fixtures come standard with Incandescent sockets. Also available with Compact Fluorescent or Metal Halide sockets.

Standard color is Gloss White. Also available the following colors: Painted Natural Aluminum, Galvanized, Textured Rust, Gloss Black, Gloss Red and Gloss Green.

Abolite Angled Reflector

Cast the perfect highlight on signs, product displays, and key architectural features.

The Abolite Angled Reflector casts the perfect highlight on signs, product displays and key architectural features. The Angled Reflector is the ideal fixture for retail space, store fronts, restaurants and other public areas.



ITEM NO.	HEIGHT (A)	DIAMETER (B)	NECK (C)	WEIGHT (LBS.)
ELAD100IG				
WT/BK White/Black	10"	7"	5"	2.0
ELAD150IG				
WT/BK White/Black	11½"	9"	5¼"	2.0
ELAD200IG				
WT/BK White/Black	13½"	11"	5½"	2.5

Other colors are available with a two week lead time

Gooseneck Wall Brackets

3/4" Single Reflector Gooseneck Wall Brackets

All brackets suitable for use in wet locations. Features rigid conduit and cast wall plate which fits 4" octagonal box (by other). Brackets are finished in gloss white powder, other optional colors are available. Wall plate included.

Standard Brackets

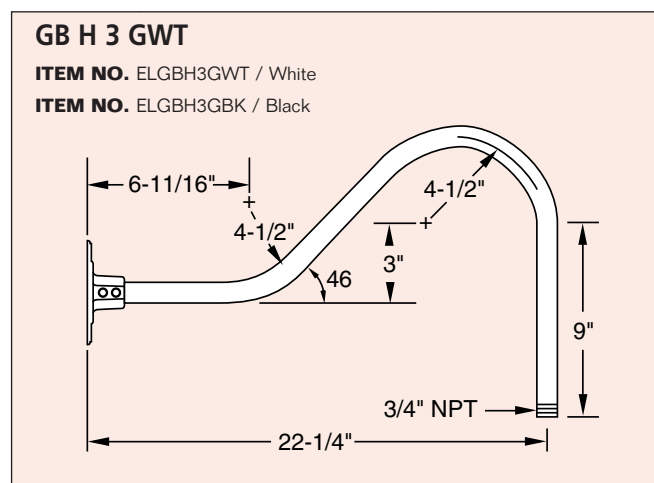
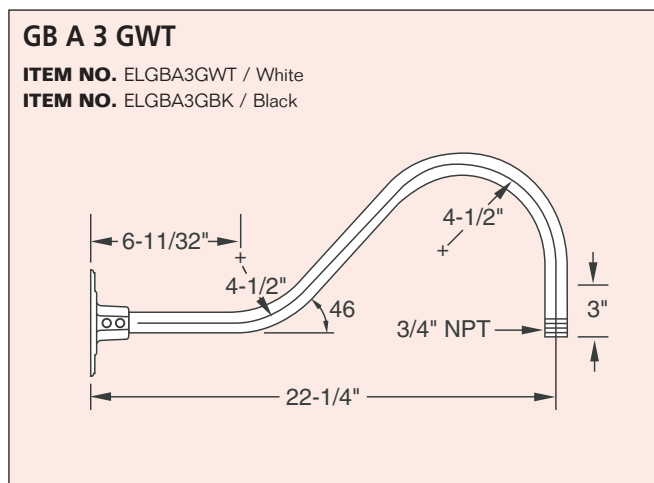

Complete line of Gooseneck Designer Lighting available upon request

Fixtures

Gooseneck Wall Brackets

GB B 3 GWT

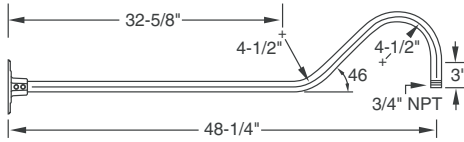

GB C 3 GWT

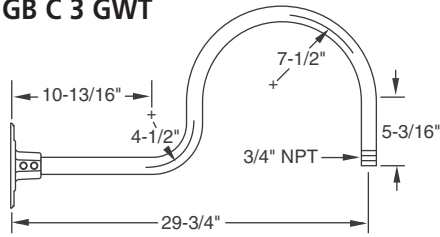

GB D 3 GWT

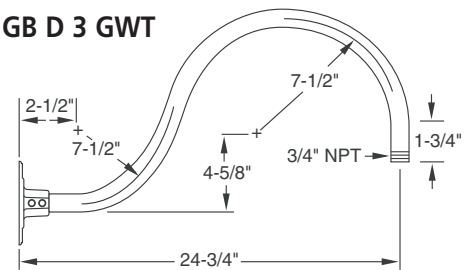

GB E 3 GWT

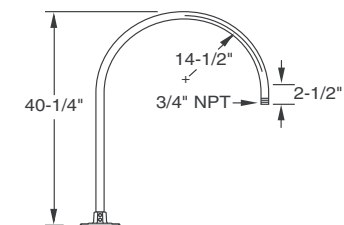

GB F 3 GWT

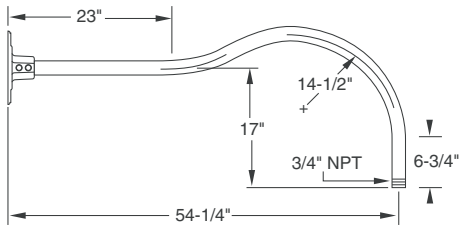

GB G 3 GWT

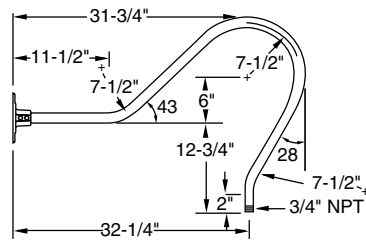

GB J 3 GWT

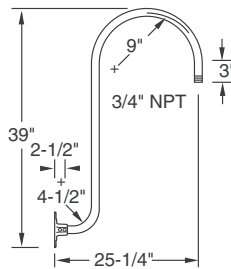

GB K 3 GWT

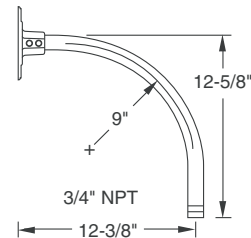

GB P 3 GWT

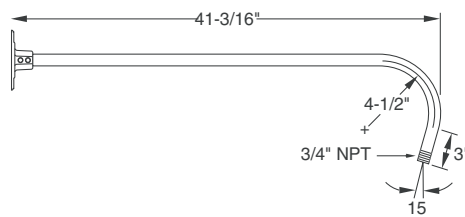

GB U 3 GWT

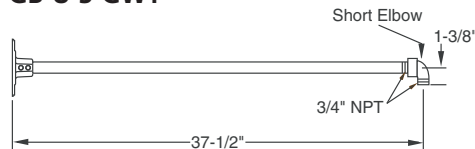

Brackets require a two week lead time

Wall Plate

Included with all GB brackets

CA 5

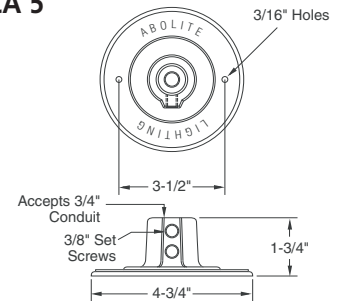

Contemporary Wall Brackets

CWBM 1GWT

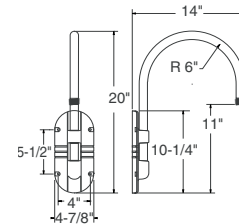

CWBL 1GWT

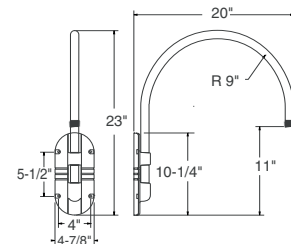

Single Reflector Wall Bracket

DWB 1 GWT

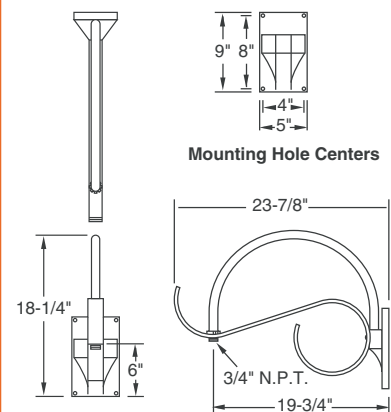

HID Lamps

HID Lamps



Bulb Shapes

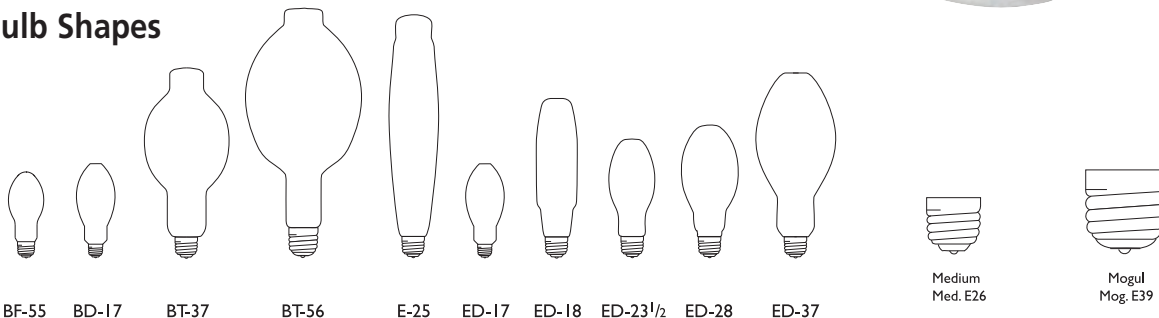

High Pressure Sodium Lamps

	WATTS	BULB TYPE	BASE	FINISH	M.O.L.	AVERAGE HOURS	LUMENS	CRI
ELHPSL35/MED	35	BF-55	Med.	Clear	5 1/6"	24,000+	2250	21
ELHPSL50/M	50	BF-55	Med.	Clear	5 1/6"	24,000+	4000	21
ELHPSL50/MED	50	ED-23 1/2	Mog.	Clear	7 3/4"	24,000+	4000	21
ELHPSL70/MED	70	BD-17	Med.	Clear	5 1/6"	24,000+	6300	21
ELHPSL70	70	ED-23 1/2	Mog.	Clear	7 3/4"	24,000+	6500	21
ELHPSL100/MED	100	BD-17	Med.	Clear	5 1/6"	24,000+	9500	21
ELHPSL100	100	ED-23 1/2	Mog.	Clear	7 3/4"	24,000+	9400	21
ELHPSL150/MED	150	BD-17	Med.	Clear	5 1/6"	24,000+	16000	21
ELHPSL150	150	ED-23 1/2	Mog.	Clear	7 3/4"	24,000+	15800	21
ELHPSL250	250	ED-18	Mog.	Clear	9 3/4"	24,000+	27000	21
ELHPSL360	360	ED-18	Mog.	Clear	9 3/4"	24,000+	46000	21
ELHPSL400	400	ED-18	Mog.	Clear	9 3/4"	24,000+	50000	21
ELHPSL1000	1000	ED-25	Mog.	Clear	15 1/6"	24,000	140000	21

Metal Halide Lamps

	WATTS	BULB TYPE	BASE	FINISH	M.O.L.	AVERAGE HOURS	LUMENS	CRI	CCT (K)
ELMHL50/MED	50	ED-17	Med.	Clear	5 1/6"	10,000	4100	85	3000
ELMHL70/MED	70	ED-17	Med.	Clear	5 1/6"	16,000	6200	85	3000
ELMHL100/ED17	100	ED-17	Med.	Clear	5 1/6"	16,000	9500	85	3000
ELMHL100	100	ED-28	Mog.	Clear	8 5/6"	10,000	8500	92	4100
ELMHL150/MED	150	ED-17	Med.	Clear	5 1/6"	16,000	14000	85	3000
ELMHL175/MED	175	BD-17	Med.	Clear	5 1/6"	10,000	13500	65	4000
ELMHL175	175	ED-28	Mog.	Clear	8 5/6"	10,000	13500	65	4000
ELMHL250	250	ED-28	Mog.	Clear	8 5/6"	10,000	20500	65	4000
ELMHL360	360	ED-37	Mog.	Clear	11 1/2"	20,000	36000	60	4300
ELMHL400	400	ED-28	Mog.	Clear	8 5/6"	20,000	36000	63	4000
ELMHL1000BT37	1000	BT-37	Mog.	Clear	11 1/2"	10,000	110000	65	3700
ELMHL1000	1000	BT-56	Mog.	Clear	12,000	110000	65	4000	
ELMHL1500BT56	1500	BT-56	Mog.	Clear	15 3/8"	3,000	155000	60	3700

Accessories

Non-Metallic Conduit

Available in 3/8" or 1/2".
100' rolls.



ITEM NO.	SIZE
NHNMC38	3/8"
NHNMC12	1/2"

Liquid Tight Metal Conduit

Available in 3/8" or 1/2".
100' rolls.

ITEM NO.	SIZE
ELTMC38	3/8"
ELTMC12	1/2"

EMT Conduit

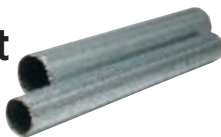

ITEM NO.	SIZE
EMT1	1" x .045 x 10'
EMT12	1/2" x .042 x 10'
EMT34	3/4" x .049 x 10'

Cable Clamps

100 per pack



ITEM NO.	SIZE	COLOR
NCC38W	3/8"	White
NCC38BK	3/8"	Black
NCC12W	1/2"	White
NCC12BK	1/2"	Black

Plastic Ties

ITEM NO.	SIZE	COLOR
LYPT4BK	4"	Black
LYPT4N	4"	Natural
LYPT7BK	7"	Black
LYPT7N	7"	Natural
LYPT11BK	11"	Black
LYPT11N	11"	Natural



Electric Tape

3/4" x 60' BLACK



ITEM NO. LYET

Liquid-Tight Metallic Conduit Connector

Made of die-cast zinc with male 1/2 inch NPT thread and locknut to fasten to a transformer enclosure.



Used to twist-on fasten 1/2 inch flexible metallic liquid tight conduit to a transformer 1/2 inch knockout.
25 per pack



ITEM NO.	DESCRIPTION
ELTCOST38	3/8" Connector Straight
ELTCOST12	1/2" Connector Straight
ELTCO9038	3/8" Connector 90° Angle
ELTCO9012	1/2" Connector 90° Angle

Liquid-Tight Non-Metallic Conduit Connector



ITEM NO.	DESCRIPTION
NHSCC38	3/8" Connector Straight
NHSCC12	1/2" Connector Straight
NH90DCC38	3/8" Connector 90° Angle
NH90DCC12	1/2" Connector 90° Angle

Wire Nuts

Our wire nuts speed installation by providing a secure fingertip grip for fast starts on the first few turns. Because no pre-twisting of conductors is required, Wire nut connectors can go on fast and easy for lower installation costs.



100/Pack. ALSO AVAILABLE IN BULK.

ITEM #	SIZE	COLOR	WIRE COMBINATION RANGE
EWNBL	X-small	Blue	300V No. 22-14 AWG Min. 1 #18 & 1 #20 – Max. 3 #16
EWNO	Small	Orange	600V No. 22-14 AWG Min. 1 #18 & 1 #22 – Max. 3 #16 & 1 #18
EWNY	Med.	Yellow	600V No. 18-10 AWG Min. 3 #18 – Max. 3 #12
EWNR	Large	Red	600V No. 18-8 AWG Min. 2 #14 – Max. 2 #10 & 2 #12

"Twist-locs" Wire Nuts

100 per pack.



ITEM #	SIZE
EWNTLM	Med.
EWNTLLG	Large

Ballast Wire

- 14 AWG, 500'
- Stranding: 19/0147 (Bare Copper)
- PVC Dual Rated, meets or exceeds UL and CSA Standards
- Meets UL 1015; rated for 105°C at 600V
- Meets UL 1032; rated for 90°C at 1000V
- Nominal O.D.: .134"



ITEM #	COLOR	ITEM #	COLOR
EW1BL	Blue	EW1OR	Orange
EW1BLK	Black	EW1R	Red
EW1BR	Brown	EW1RW	Red/White
EW1BW	Blue/White	EW1W	White
EW1GR	Green	EW1YE	Yellow
EW1OBK	Orange/Black		

Wire strippers on page 298

Toggle Switch with Boot

- Supplied with locknut and on-off
- 6" lead wires
- UL listed, CSA Certified
- Made in the USA



ITEM NO. ETSWB

Toggle On/Off Plate

ITEM NO. ETSP84613



Flashers

Model 1 Flashers

This basic unit is powered by a synchronous motor that drives one or two cams at a constant speed of 5 seconds per revolution, or 12 revolutions per minute. The cams in turn open and close contact points. Actual flashing speed is a function of the cam cut. For example, a 4 lobe cam would yield on-off action 48 times per minute. Several cam cuts are available from stock, and custom cam cuts are available per the customer's request.

115 volt motor, 50/60 cycle. UL and cUL listed.

Also available in 220 volt.

Size: 3.5" x 4" x 3"

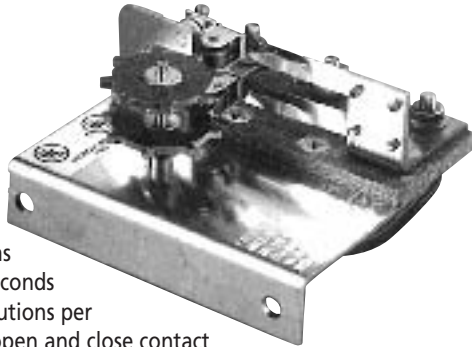

Cam cuts in bold are standard and will be supplied unless a different cam cut is requested.

ITEM NO.	NO. OF CIRCUITS	CAM CUT	FLASHING ACTION PER MINUTE
1-01A	1	Fifty/Fifty	On-Off x 12
		Quarter/Quarter	On-Off x 24
		4 Lobe	On-Off x 48
		8 Lobe	On-Off x 96
1-02	2	Fifty/Fifty	On-Off x 12
		Quarter/Quarter	On-Off x 24
		4 Lobe	On-Off x 48
		8 Lobe	On-Off x 96
1-A2	2	Fifty/Fifty	On-Off x 12
		Quarter/Quarter	On-Off x 24
		4 Lobe	On-Off x 48
		8 Lobe	On-Off x 96
		Steady/Arrow	Alternate/Steady 5 Times

Model 22 Flashers

This Model has proven itself over many year to be a very reliable and economical way to add on-off, alternating, or color changing effects to a sign or other device. Features include cams and points out in the open for easy replacement or adjustment. The ball bearing mounted, sealed cam shaft with large fly wheel makes for years of smooth, quiet, maintenance free service.

Contacts on the Model 22 are rated to handle 15 amps, except on the chaser action units whose contacts are rated at 10 amps due to the high flashing speed. Model 22 High Output flashers are constructed with extra insulation and an increased point opening to minimize arcing when used in high initial draw applications such as flashing ballasts.

115 volt motor, 50/60 cycle. UL and cUL listed.

Also available in 220 volt.

Size: 5 x 4.5 x 3

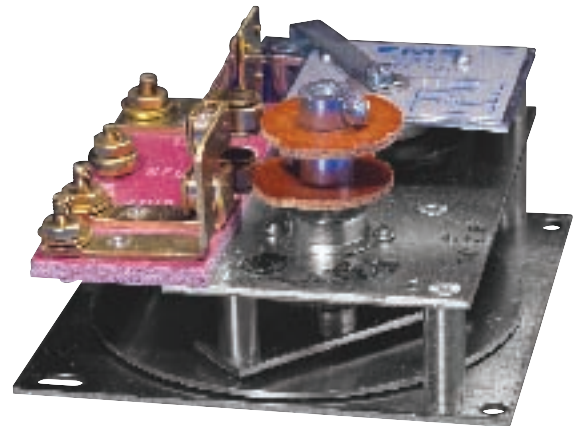

ITEM NO.	NUMBER CIRCUITS	FLASHING ACTION	CAM CUT	FLASHES PER CIRCUIT/MIN	TOTAL WATTS CAPACITY AT 115 VOLTS
NF 22-01	1	Off and On	50/50 Synchronous	20-30	1725
NF 22-01-HO	1	Off and On	50/50 Synchronous	20-30	1725
NF 22-02	2	Off and On	50/50 Synchronous	20-30	3450
NF 22-02-HO	2	Off and On	50/50 Synchronous	20-30	3450
NF 22-A2	2	Alternate	50/50 Alternating	40	3450
NF 22-A2-HO	2	Alternate	50/50 HO Alternating	20-30	3450
NF 22-A2S	2	Alternate	50/50 Alternating	40	3450
NF 22-S1	1	Specify	Specify	Specify	1725
NF 22-S2	2	Specify	Specify	Specify	3450

Chasers / Flashers

Chasers / Flashers

Model 33 Chasers

This Chaser is most commonly used on flashing incandescent bulb signs where "Dark Spots" chase around a border or directional motion is incorporated into a field of bulbs. The Model 33 can be used to chase neon, though it must be incorporated on the primary side of any transformers. Available from stock with three, four, or five circuits, and larger chasers are available by special order.

Model 33 chasers are ruggedly constructed to provide years of smooth, quiet, trouble free service. The Model 33 chaser features molded terminal blocks, permanently lubricated bearings, and all corrosion resistant surfaces. Contacts on the Model 33 chasers are rated to handle 10 amps each and are accessible for easy replacement.

115 volt motor, 50/60 cycle. UL and cUL listed. Also available in 220 volt.

33-C3/C4 Size: 6.5 x 5 x 4.75 33-C5 Size: 8 x 5 x 4.75

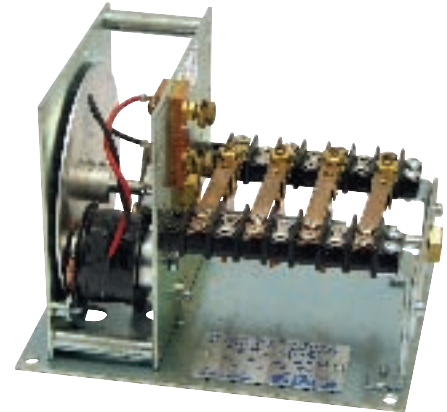

ITEM NO.	NO. OF CIRCUITS	CAM CUT	FLASHES PER CIRCUIT PER MINUTE SHADE ON	FLASHES PER CIRCUIT PER MINUTE SHADE OFF	TOTAL WATTS CAPACITY AT 115 VOLTS
ECH 33-C3	3	8 Lobe	270	210	3450
ECH 33-C4	4	8 Lobe	270	210	4600
ECH 33-C5	5	7 Lobe	215	190	5750

Model 66 High Speed Scintillator or Chaser

The Model 66 is generally used to create a scintillating or "twinkling" action. This unit is constructed of heavy duty materials to stand up under constant use with heavy loads. The Model 66 features a simple wiring design for easy installation, and three shielded ball bearings which require no maintenance. Contacts are formed of a special silver alloy that performs better than pure silver.

The flashing speed of the Model 66 can be easily adjusted by removing motor shades using just a screw driver. The flasher is supplied with a shade on each motor, and as shades are removed the flashing speed decreases. When operating with shades on (430 flashes per circuit per minute) the contacts on all Model 66 units are rated at 12.5 amps each. When operating with shades off (250 flashes per circuit per minute) the contact on the 3 and 4 point units are rated at 20 amps each, while the contacts on the 5 and 6 point units are rated at 17.5 amps each.

115 volt motor, 50/60 cycle. UL and cUL listed. Also available in 220 volt.

66-C3/C4 Size: 7 x 6 x 4 66-C5/C6 Size: 7.25 x 9 x 4

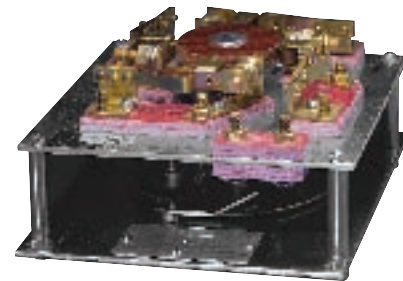

ITEM NO.	CIRCUITS	SHADE ON	SHADE OFF
ECH 66-C3	3	4300	6900
ECH 66-C4	4	5750	9200
ECH 66-C5	5	7125	10050
ECH 66-C6	6	8625	12075

Model 55 High Voltage Flasher *Neon Animator*

Specifically designed to distribute the secondary voltage of a neon transformer. The unit will handle from 7,500 to 15,000 volts and distribute this high voltage to up to 8 circuits from a single transformer. For this reason the Model 55 is occasionally referred to as a "neon animator".

The Model 55 is housed in a stainless steel cabinet with insulation of electrical quality glazed porcelain. The magnetic speed adjusted can vary the flashing speed from 35 to 300 plashes per minute.

The Model 55 is a rather strong generator of Electro Magnetic Interference (EMI), sometimes referred to as Radio Frequency Interference (RFI). Various precautions can be observed to significantly reduce this interference, but it may not be totally eliminated. This potential problem should be considered when selecting installation locations.

115 volt motor, 50/60 cycle. UL and cUL listed. Also available in 220 volt.



ITEM NO.
NF55A4
NF55A6
NF55A8

Spellers

Model 33 Spellers

Designed for applications where electric circuits are to be flashed in custom sequences such as with spelling or other animation. Variable in both cycle speed and cam cut, Model 33 spellers are some of the most versatile sign controllers available. The flashing sequence on each Model 33 speller is custom made to customers specifications. The units can be built with as few as one circuit, or as many as necessary to accommodate the requested flashing sequence. Neon can be controlled by installing the speller on the primary side of transformers.

115 volt motor, 50/60 cycle. UL and cUL listed.

Also available in 220 volt.

To aid customers in ordering Model 33 Spellers, please refer to the speller sequence charts. "Cycle" refers to the time required for the flashing action to go through its complete performance and start to repeat. "Circuit" refers to the current controlled by one cam and one set of contact points. The time on for a circuit is indicated by a solid square, the time off by a blank square. The charts show some of the more common sequences, but nearly any sequence can be constructed. Complete your own chart for a custom sequence

CYCLE TIME IN SECONDS



Sequence One

- 1 on, 2 on, 3 on, 4 on, 5 on, 6 on
- All off / All on / All off
- Repeat

CYCLE TIME IN SECONDS



Sequence Two

- 1 on, 2 on, 3 on, 4 on, 5 on, 6 on
- All off
- Repeat

CYCLE TIME IN SECONDS



Sequence Three

- 1 on-off, 2 on-off, 3 on-off, 4 on-off, 5 on-off, 6 on-off
- All off
- Repeat

CYCLE TIME IN SECONDS

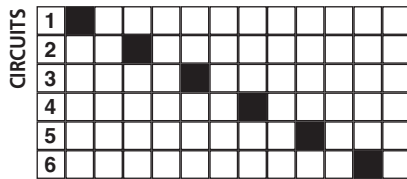

Sequence Four

- Same as sequence three except some off period between each on segment.

CYCLE TIME IN SECONDS

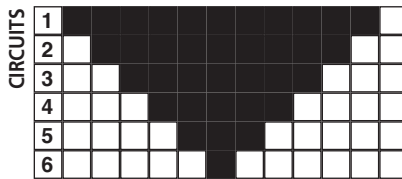

Sequence Five

- Wipe on, Wipe off.
- All off
- Repeat

ITEM NO.	# OF CIRCUITS	SPEED IN SEC./CYCLE
ESP 33-S1F	1	2-8
ESP 33-S1M	1	4-20
ESP 33-S1S	1	8-40
ESP 33-S1XS	1	18-90
ESP 33-S2F	2	2-8
ESP 33-S2M	2	4-20
ESP 33-S2S	2	8-40
ESP 33-S2XS	2	18-90
ESP 33-S3F	3	2-8
ESP 33-S3M	3	4-20
ESP 33-S3S	3	8-20
ESP 33-S3XS	3	8-40
ESP 33-S4F	4	18-20
ESP 33-S4M	4	2-8
ESP 33-S4S	4	4-20
ESP 33-S4XS	4	8-40
ESP 33-S5F	5	18-90
ESP 33-S5M	5	2-8
ESP 33-S5S	5	4-20
ESP 33-S6M	6	18-90
ESP 33-S6S	6	4-20
ESP 33-S6XS	6	8-40
ESP 33-S7M	7	18-90
ESP 33-S7S	7	4-20
ESP 33-S7XS	7	8-40
ESP 33-S8M	8	18-90
ESP 33-S8S	8	4-20
ESP 33-S8XS	8	8-40
ESP 33-S9M	9	18-90
ESP 33-S9S	9	4-20
ESP 33-S9XS	9	8-40
ESP 33-S10M	10	18-90
ESP 33-S10S	10	4-20
ESP 33-S10XS	10	8-40
ESP 33-S11S	11	8-40
ESP 33-S11XS	11	8-40
ESP 33-S12S	12	18-90
ESP 33-S12XS	12	8-40
ESP 33-S13S	13	18-90
ESP 33-S13XS	13	8-40
ESP ESP 33-S14S	14	18-90
ESP 33-S14XS	14	8-40
ESP 33-S15S	15	18-90
ESP 33-S15XS	15	8-40
ESP 33-S16XS	16	18-90
ESP 33-S17XS	17	18-90
ESP 33-S18XS	18	18-90
ESP 33-S19XS	19	18-90
ESP 33-S20XS	20	18-90

Timeclocks / Photocontrol

Indoor Timeclock

24-hour Time Clock

Perfect choice for controlling HVAC systems, Pool/Spa Heaters and Filters, Fans/Motors/Pumps/ Blowers, Electric Fences, Conveyers or many other types of applications. The 24-hour dial accommodates 2 to 14 replaceable trippers for 1 to 7 on/off operations per day.

- Tamper-Proof Enclosure
- Skip-A-Day Option
- All-Steel Mechanism
- 1-7 On/Off Operations per Day
- Manual Override



ITEM NO.	USE	VOLTS 60 HZ	SWITCH	SWITCH RATING PER POLE				TYPE(NEMA)	ENCLOSURE		
				AMPS	AMPS T	VA	HP		HEIGHT	WIDTH	DEPTH
ETC-101	Indoor	120	SPST	40	40	690	1	1	7 ⁷ / ₃₂ "	4 ⁹ / ₁₆ "	2 ¹⁵ / ₁₆ "
ETC-103	Indoor	120	DPST	40	40	690	1	1	7 ⁷ / ₃₂ "	4 ⁹ / ₁₆ "	2 ¹⁵ / ₁₆ "
ETC-104	Indoor	208-277	DPST	40	40	690	1	1	7 ⁷ / ₃₂ "	5 ⁹ / ₁₆ "	2 ¹⁵ / ₁₆ "

7-Day Time Clock

These general purpose time controls feature a 7-day dial, graduated into the 7 days of the week. Each day subdivided into light (day) and dark (night) portions, each with 30 minute increments. The dial can accommodate up to 28 trippers that provide for 4 on/off operations each day and a total of 28 per week.

- Tamper-Proof Enclosure
- Independent 4-Pole Design
- All-Steel Mechanism
- 4 On/Off Operations per Day
- 28 On/Off Operations per Week
- Manual Override

Replacement Trippers

Set: 1 on, and 1 off



ITEM NO. ETCTR

Outdoor timeclocks also available. Please contact your sales rep for information.

Photocontrol

TL Series

Photocontrol in slim profile housing with 1/2" pipe nipple

The TL series controls have a thin cylindrical shape to fit neatly between twin floodlights and in other tight applications. These controls are equipped with a field adjustable swivel base that makes it easy to direct the photocell away from stray light and is "O" ring sealed to prevent water from entering through the knuckle. The TL control also features a heavy-duty thermal bi-metal switch that provides a 30-45 second time delay. This virtually eliminates unwanted lamp cycling that could be caused by lightning, car headlights, or other sudden changes in the ambient light level.

- Adjustable Swivel Base
- Thinline Profile - Perfect for Tight Spots
- UL Listed
- Durable Polycarbonate Housing



ITEM NO.	RATED VOLTS	RANGE (VOLTS)	LOAD RATING	LOAD RATING
			TUNGSTEN (WATTS)	BALLAST (VA)
EPC (#TL-115)	120	105 - 130	1800	1100
EPCSPT15	120		2000	1900
EPCAT15	120			

Other Available Models:

Please contact your sales rep for details on specific model.

AT Series

Photocontrol in a vandal proof Die-Cast Aluminum Housing with 1/2" pipe nipple

PT/SPT Series

Photocontrol in a non-metallic housing with a 1/2" pipe nipple

BF Series

Locking style photocontrol with surge protection for industrial and commercial applications

AA Series

Button type photocontrol for mounting with in enclosures such as luminaires and outlet boxes



EPCAT15



EPCSPT15

Rotators

Indoor Rotators

All indoor rotators are available with or without collector ring.

IG-1 Models

The IG-1 is the ideal turntable to rotate small loads with ease. Used as a display turntable or inside of a small rotating sign, this unit can rotate up to 20 lbs.



- Max. Weight Capacity** 20 lbs.
- RPM** 2 1/2
- AMP Load Limit** (collector) 10A, 115V
- Bearings** Sealed Ball
- Motor Draw** 0.02A (3 Watts)
- Safety Clutch** Standard Feature

ITEM NO.	DESCRIPTION
DYN-IG-1WR	with collector ring
DYN-IG-1	less collector ring

IG-2 Models

Dependable performance, durable construction and safety conscious. The IG-2 is capable of rotating your indoor sign or turntable weighing up to 150 lbs.

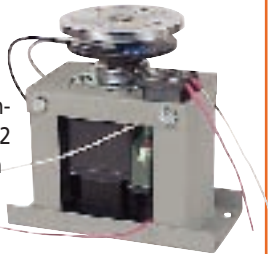

- Max. Weight Capacity** 150 lbs.
- RPM** 1, 2 (standard), or 6
- AMP Load Limit** (collector) 15A, 115V
- Bearings** Sealed Ball
- Motor Draw** 0.4A (46 Watts)
- Safety Clutch** Standard Feature

ITEM NO.	DESCRIPTION
DYN-IG-2WR	with collector ring
DYN-IG-2	less collector ring

Also available other models with a stronger weight capacity. Please contact your sales rep

Outdoor Rotators

Rotating mechanisms provide motion that attracts attention, leads to interest and results in profit!

Planning with an edge above the competition makes a big difference in selling. One way to market aggressively is to have action attraction on your side. Movement against a stationary background is eye catching and lends renewed visibility over and over from any viewpoint. The 360° motion also shows the whole picture to customers with continuously interesting action.

Turntables have been designed with reliability, stability and ruggedness in mind.

A safety torque relief clutch provides assurance that the turntable will slip under overload conditions, rather than create an aggravatingly dangerous motor burnout.

Special-Action Models available on request – Such as oscillating, indexing, variable speed, fast motion slow motion, revolving display table and other special-action units.

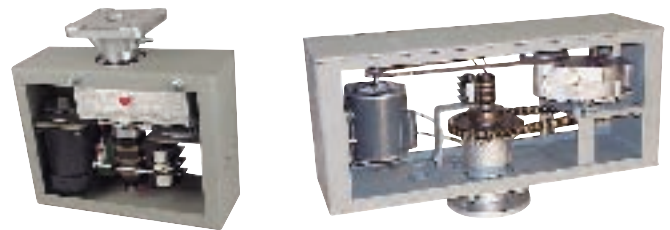

Many standard models available designed to power revolving signs requiring torques up to 800 ft. lbs.
Consult your S&F sales rep for additional information.

Clocks

Outdoor Clock Movements

We offer a full variety of products for your outdoor clock and thermometer needs. Choose from a basic model clock movement which can handle dials from 18"-42", to a heavy duty model which can handle dials from 12'-22"! Also available a series of clock movements that have collector rings to carry 120V AC current to neon transformers mounted in the tail section of each hand, used for hands outlined in neon tubing. Do you need a 2-way clock movement or perhaps a 4-way ideal for tower installation? Look no further than S&F. One of our knowledgeable sales rep will be able to advise and assist you with all your needs.

2M Series Clock Movements For Dial Sizes 18" to 42"

This movement provides sufficient power to drive balanced hands for dial sizes up to 42 inches. It center mounts directly to the clock dial. No cover glass is required to protect hands, which are set easily by turning the minute hand. A No. 970 Remote Reset Control for setting time is optional. It allows one to stop the clock or advance the hands 10 times faster. Also available are shaft extensions for setting the movement back from translucent acrylic dials to eliminate dial shadow or accommodate thick walls.

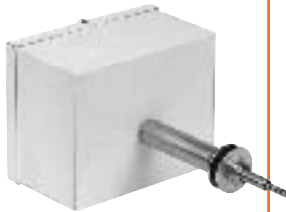

DIAL SIZE	ITEM NO.	ITEM NO. WITH REMOTE RESET CONTROL
18"	2M-9	2MR-9
24"	2M-11	2MR-11
30"	2M-14	2MR-14
36"	2M-16	2MR-16
42"	2M-18	2MR-18

3MR Series Clock Movements For Dial Sizes 18" to 48"

This direct drive movement features a synchronous capacitor motor, which develops ample torque for one or two-way clock installations. The standard dimension between opposing two-way dials can be 9" minimum to 16" maximum. The No. 970 Remote Reset Control is provided for setting hands. Shaft extensions can be furnished when requested.

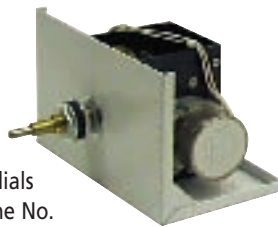

DIAL SIZE	SINGLE FACE ITEM NO.	DOUBLE FACE ITEM NO.
18"	—	3MDR-9
24"	3MR-11	3MDR-11
30"	3MR-14	3MDR-14
36"	3MR-16	3MDR-16
42"	3MR-18	—
48"	3MR-21	—

Open Faced Clocks

Our durable outdoor clock movements combined with markers will complement today's architectural treatments and are ideal for lobby or outdoor decoration.



The movements can either be front mounted (-FM) with the mounting plate flush to the wall or rear mounted with extension shafts through the wall. The standard markers are 1/4" thick aluminum and can be installed with adhesive on smooth surfaces, or can be ordered with mounting studs for uneven surfaces. Standard enamel finishes available for the hands and markers are black, aluminum or white. Consult your S&F sales rep for other finishes.



Standard Hands

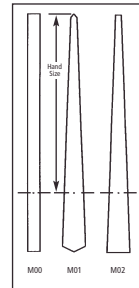

Special Hands

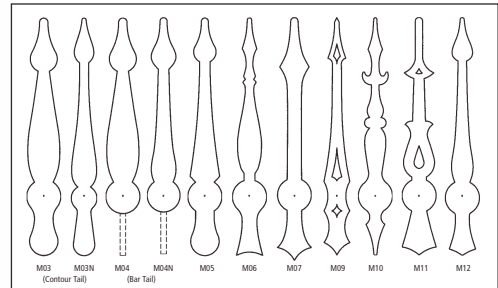

Clock Setting Controls

Remote Reset Controls

This attachment is available for all clock movements. The clock is wired (with 3 wires) to a conveniently located Reset Control Panel. The Control provides remote setting of clock hands by either stopping the clock or advancing the hands at a 10:1 reset rate.



A Master Reset Control Panel is available for operating from two to four clocks, which includes a master switch for group correction and separate switches for individual clock correction.





www.sfsupplies.com

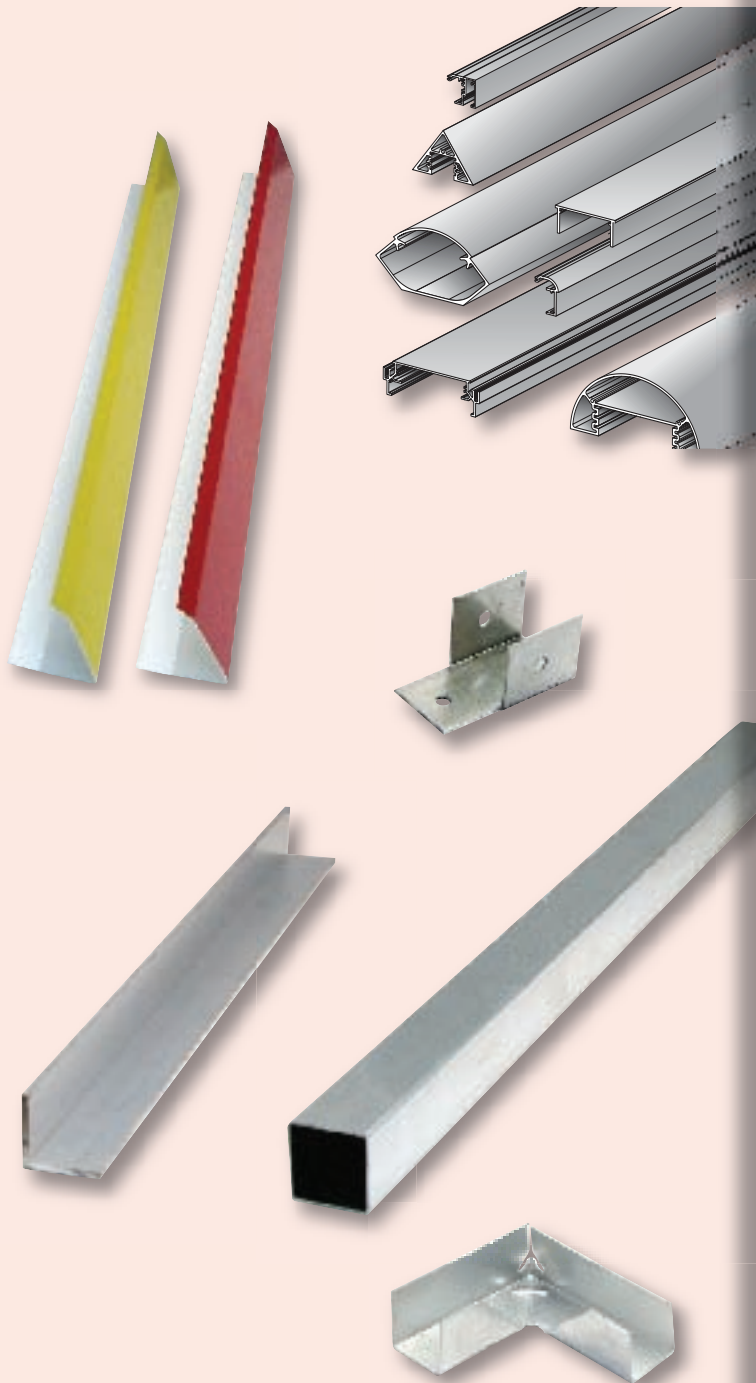

INDEX

DIGITAL MEDIA	5
SIGN VINYL	45
VINYL AND WRAP SUPPLIES	59
WIDE FORMAT EQUIPMENT	73
VINYL CUTTERS	87
ENGRAVERS	95
SOFTWARE	97
SUBSTRATES	105
BANNER	127
SIGN DISPLAY	139
TAPES & ADHESIVES	145
PAINT	153
NEON SUPPLIES & EQUIPMENT	167
TRANSFORMERS	207
LED SYSTEMS	229
LIGHTING & ELECTRIC	243
SIGN EXTRUSION	267
Architectural Extrusions	268
Aluminum Tubing & Molding	269
Light Box Frame System	270
SignComp Extrusion	271-276
LETTER & ACCESSORIES	277
MOUNTING HARDWARE	281
EQUIPMENT & SHOP TOOLS	293

Architectural Extrusions

90° Aluminum Molding

.024 Gauge.

ITEM NO.	SIZE	COLOR
AM1BK90	1" x 10'	Black
AM1W90	1" x 10'	White



Aluminum Divider Bar

Mill finish.

ITEM NO.	SIZE
ADB11224	1-1/2" x 24'

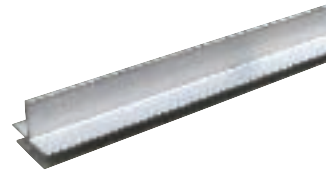

Steel Galvanized "J" Molding

1" x 1" x 1/4" x 1/4" x 10',

22 gauge

ITEM NO.
AMGL

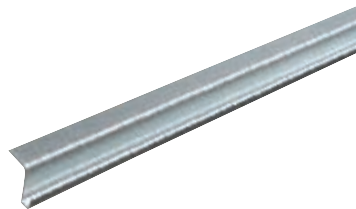

Extruded Angle

3/4" x 1"

.50 gauge

ITEM NO.	DESCRIPTION
AWECAAN12CA	12' Clear Anodized
AWECAAN20CA	20' Clear Anodized

Architectural Aluminum Angle

20' length.

Mill finish.

ITEM NO.			
AAN1X34X18	1/8"	1" x 3/4"	#4.78/lb.
AAN1X1X18	1/8"	1" x 1"	#5.50/lb.
AAN125X125X18	1/8"	1 1/4" x 1 1/4"	#7.12/lb.
AAN150X150X18	1/8"	1 1/2" x 1 1/2"	#8.62/lb.
AAN2X1X18	1/8"	2" x 1"	#8.44/lb.
AAN2X2X18	1/8"	2" x 2"	#11.62/lb.
AAN125X125X316	3/16"	1 1/4" x 1 1/4"	#10.44/lb.
AAN150X150X316	3/16"	1 1/2" x 1 1/2"	#12.62/lb.
AAN2X2X316	3/16"	2" x 2"	#16.82/lb.
AAN2X2X14	1/4"	2" x 2"	#22.48/lb.



Learn more about our many fine products at our website
www.sfsupplies.com

In addition to item description and specs you can view large detailed images of all the items



MasterCatalog.pdf

A PDF version of our Master Catalog is available on our site for you to download

Aluminum Tubing

1" x 1" x 20',
.029 Gauge

These square aluminum tubing have many uses in the sign industry. They are ideal for all signs, frames, & lightboxes.

ITEM NO. ATS



Always in stock with the best prices!

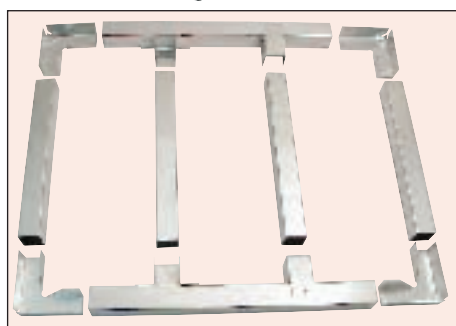

These aluminum accessories are used to join the tubing together.

Aluminum Corner

For 1" tubing

ITEM NO. ACOS

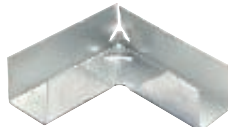

Aluminum Center Straight

For 1" tubing

ITEM NO. ACENS



Aluminum Center T Style

For 1" tubing

ITEM NO. ACENT



Aluminum Tubing

These aluminum accessories are used to mount 1" tubing to the wall.

Steel End Tab

For 1" tubing

ITEM NO. ATET



Aluminum Wall Bracket

For 1" tubing.

Box of 25.

ITEM NO. ATWB1



Aluminum Tube Connector

For 1" tubing.

Used to join two aluminum tubes.

ITEM NO. ATCO



Aluminum Molding

.024 Gauge

These moldings were specially created to use as an edge for aluminum signs. Create a frame with the Aluminum Extruded Tubing (item#ATS), then mount your aluminum sign to the frame. Cut these Aluminum Moldings to size and use on all four edges to give a professional and most sophisticated look. Aluminum moldings are available in many colors.

We also bend custom moldings to your specifications. Any shape or specific needs can be ordered.

1" Molding:

1" x 1" with 1/4" lip on one side

2" Molding

1½ x 2" with 3/8" lip on the 2" side

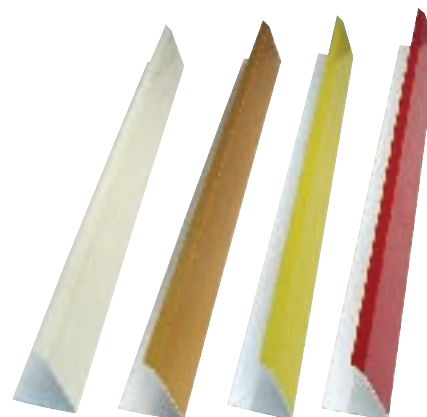

ITEM NO.	SIZE	COLOR
AM1BZ	1" x 10'	Bronze
AM1BK	1" x 10'	Gloss Black
AM1G	1" x 10'	Gold Painted
AM1GR	1" x 10'	Green
AM1B	1" x 10'	Heron Blue
AM1I	1" x 10'	Ivory
AM1MBK	1" x 10'	Matte Black
AM1M	1" x 10'	Mill Finish
AM1PB	1" x 10'	Pepsi Blue
AM1R	1" x 10'	Red
AM1W	1" x 10'	White
AM1Y	1" x 10'	Yellow

ITEM NO.	SIZE	COLOR
AM2BK	2" x 10'	Black
AM2BZ	2" x 10'	Bronze
AM2BR	2" x 10'	Brown
AM2G	2" x 10'	Gold Painted
AM2GR	2" x 10'	Green
AM2BL	2" x 10'	Heron Blue
AM2I	2" x 10'	Ivory
AM2MBK	2" x 10'	Matte Black
AM2M	2" x 10'	Mill Finish
AM2MO	2" x 10'	Mochatan
AM2R	2" x 10'	Red
AM2W	2" x 10'	White
AM2Y	2" x 10'	Yellow

Light Box Frame System



Create a light box in just a few easy steps:

- Cut the aluminum siding or chaser siding to size. For the chaser siding, knock out the holes for the socket using a die punch. Assemble the sides with screws or rivets. Attach back panel.
- For added strength, a frame can be build from our aluminum tubing (see picture).
- Prepare the socket raceway with knock outs for the socket. Attach to both sides of the box.
- Connect all the wiring as needed.
- For the front panel use white plastic sheet, secure it by attaching the aluminum molding on all four sides

We have all the supplies you need to create custom light boxes.

Aluminum Siding

.040 Gauge

Pre formed and ready to use.

Available for single sided or double sided lightbox. Just cut to size and then assemble siding using screws or rivets.

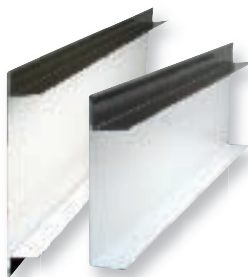

ITEM NO.	SIDES	SIZE	COLOR
AS11S5BK	1 Side	5" x10'	Black
AS11S5BZ	1 Side	5" x10'	Bronze
AS11S7BK	1 Side	7" x10'	Black
AS11S7BZ	1 Side	7" x10'	Bronze
AS11S7WH	1 Side	7" x10'	White
AS11S9BK	1 Side	9" x10'	Black
AS11S9BZ	1 Side	9" x10'	Bronze
AS11S9WH	1 Side	9" x10'	White
AS12S9BK	2 Side	9" x10'	Black
AS12S9BZ	2 Side	9" x10'	Bronze
AS12S9WH	2 Side	9" x10'	White

Aluminum Light Box Molding

.040 Gauge

Attach molding to front panel. Molding will hold the front plastic sheet in place.

Size: 1 1/2" x 1 1/2" x 1/2" x 120"



ITEM NO.	LENGTH	COLOR
ASILBMBK	10'	Black
ASILBMBZ	10'	Bronze
ASILBMCA	10'	Clear Anodized
ASILBMW	10'	White

Aluminum Chaser Siding

.040 Gauge

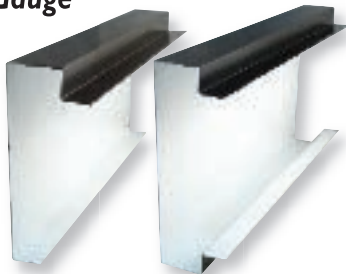

Chaser siding is designed to be used for light boxes with chasing lights. Single sided or double sided available. Use an Eagle Socket Punch to knock out holes for the sockets as needed.

ITEM NO.	SIDES	SIZE	COLOR
ASICH1S7BK	1 Side	7" x10'	Black
ASICH1S7BZ	1 Side	7" x10'	Bronze
ASICH1S9BK	1 Side	9" x10'	Black
ASICH1S9BZ	1 Side	9" x10'	Bronze
ASICH2S9BK	2 Side	9" x10'	Black
ASICH2S9BZ	2 Side	9" x10'	Bronze

Reverse Molding

.040 Gauge

Attach molding to front panel. Molding will hold the front plastic sheet in place. Designed for chaser siding.

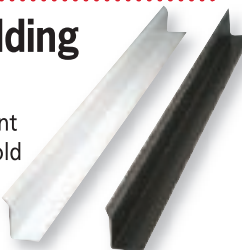

ITEM NO.	SIZE	COLOR
AMRBZ	3/4" x1" 10'	Bronze
AMRBK	3/4" x1" 10'	Gloss Black
AMRW	3/4" x1" 10'	White

Socket Raceway

The Socket Raceway gets attached on two sides of the box. Use a socket punch to knock out holes for the sockets as needed. Corner raceway is used when bulbs are towards the rear of the box. The middle raceway is used with spring sockets for double-sided light box.

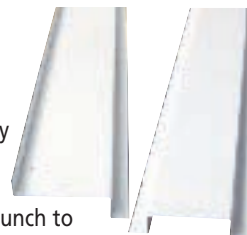

ITEM NO.	DESCRIPTION
ASRC	Socket Raceway Corner
ASRM	Socket Raceway Middle

Aluminum Louvers

Louvers with screen, are used on the side panels of light boxes to let heat from inside escape.



ITEM NO.	SIZE
HDLO1	1"
HDLO2	2"
HDLO3	3"
HDLO4	4"

Aluminum Piano Hinge

Mill finish, thickness is .060.

ITEM NO.	SIZE
APH2HD	2" x 84" (1" x 1")

Also available in 2 1/2", 3" & 4" as a special order



SignComp Extrusion

S&F State-Of-The-Art Extrusion Cutting Facility



Our trained professionals will produce your sign cabinet requirements. All measured, cut and mitered to your specifications in our own facility. Your order comes complete and ready to assemble. Includes all corner keys, angles, and screws needed.



SignComp extrusions are available in the following series:

EconoComp Series

The EconoComp series of extrusions have a lighter wall and are designed to use for basic light boxes up to 6' x 8'.

Standard Series

The Standard series of extrusions are made with a heavy wall and are used for larger size light boxes. Many more extrusion options are available in this series.

Commercial Series

Engineered for flexible, rigid and aluminum face pylon and wall mount signage. Product line includes Hingeable Retainers and Cabinets, Retro Frame Systems, Radius Corners, Divider Bars, Radius Ends, Vandal Covers.

Architectural Series

Engineered to execute a variety of post and panels, low profile, wall mount and monument signs as well as monolithic signage. Product line includes Hingeable Retainers, Radius Ends, Unique Post and Panel Shapes, Interchangeable Message Panels and Dividers.

Sign Cabinet Fillers



EconoComp Extrusion

#2034 Single Face Filler

ITEM NO.	FINISH
SC2034M	Mill Finish
SC2034P	Bronze Painted

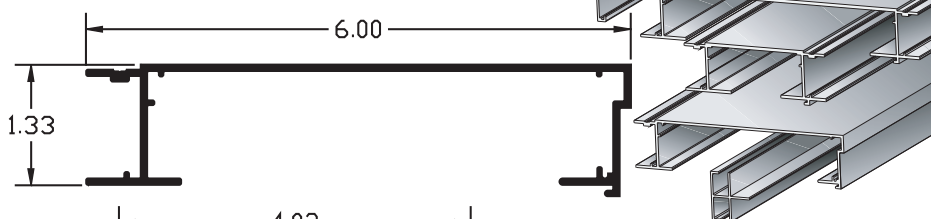

#2036 Medium Double Face Filler

ITEM NO.	FINISH
SC2036M	Mill Finish
SC2036P	Bronze Painted

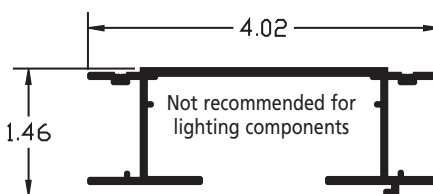

#2032 Large Double Face Filler

ITEM NO.	FINISH
SC2032M	Mill Finish
SC2032P	Bronze Painted

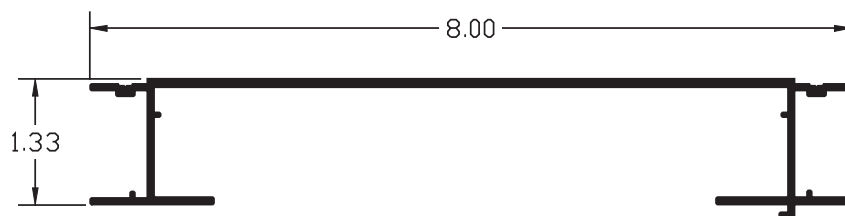

Moldings



#2056 Econo Molding

ITEM NO.	FINISH
SC2056M	Mill Finish
SC2056P	Bronze Painted

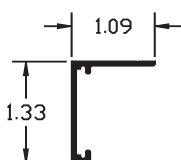

#2058 Extended Econo Molding

ITEM NO.	FINISH
SC2058M	Mill Finish
SC2058P	Bronze Painted

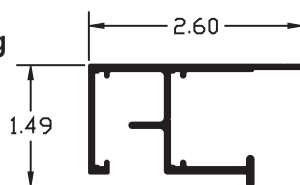

Divider



#2140 1-5/16" Econo Divider

ITEM NO.	FINISH
SC2140M	Mill Finish
SC2140P	Bronze Painted

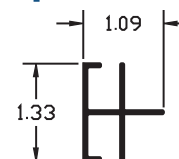

Components/Hardware

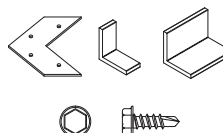

ITEM NO.	DESCRIPTION
SC5210	Corner Key
SC5325	Divider Angle
SC5335	Extended Divider Angle
SC5217	Screw

SignComp Extrusion

Standard Extrusion



Sign Cabinet Bodies

1 Part 12" Double Face Body
ITEM NO. SC1924

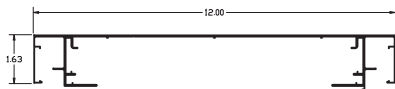

2 Part 12" Double Face Body
ITEM NO. SC1929

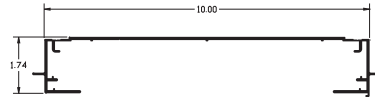

1 Part 9" Double Face Body
ITEM NO. SC1923

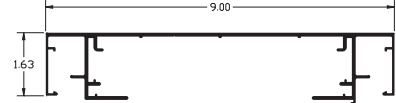

2 Part 9" Double Face Body
ITEM NO. SC1928

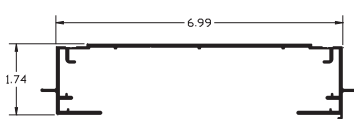

1 Part 8" Single Face Body
ITEM NO. SC1922

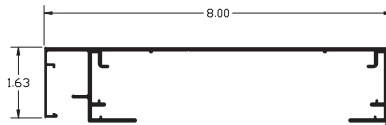

2 Part 8" Single Face Body
ITEM NO. SC1927

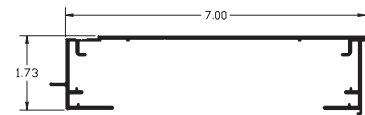

1 Part 6" Single Face Body
ITEM NO. SC1921

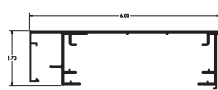

2 Part 6" Single Face Body
ITEM NO. SC1926

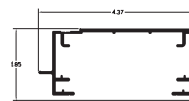

Retainers



2 Part Retainer
ITEM NO. SC1944

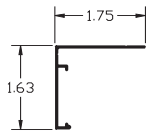

2 Part Extended Retainer
ITEM NO. SC1940

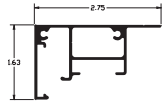

2 Part Extended Frame
ITEM NO. SC1955

2 Part Large Extended Retainer
ITEM NO. SC1939

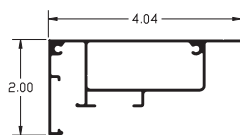

Vandal System



2 Part Inner Frame
ITEM NO. SC1960

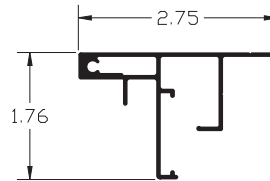

2 Part Outer Frame
ITEM NO. SC1942

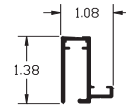

2 Part Large Inner Frame
ITEM NO. SC1959

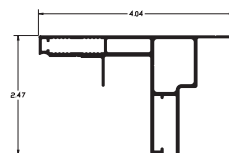

2 Part Extended Frame
ITEM NO. SC1941

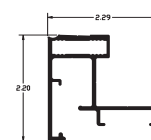

Dividers



2 Part Divider
ITEM NO. SC1905

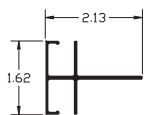

1-1/2" Standard Divider
ITEM NO. SC1910

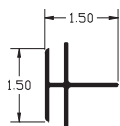

2-1/2" Standard Divider
ITEM NO. SC1920

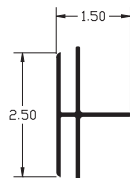

Socket Raceways



Socket Raceway
ITEM NO. SC1984



Socket Raceway II
ITEM NO. SC1985

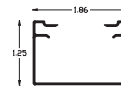

Socket Raceway Cover
ITEM NO. SC1987

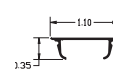

SignComp Extrusion

Standard Extrusion



Transformer Raceways

1 Piece Transformer Raceway

ITEM NO. SC1980

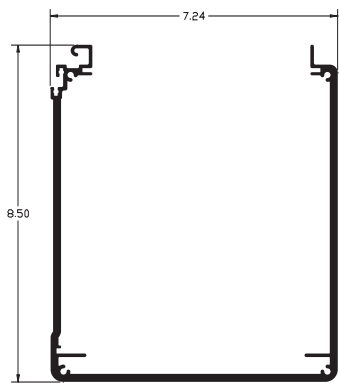

2 Piece Transformer Raceway-Front

ITEM NO. SC1981

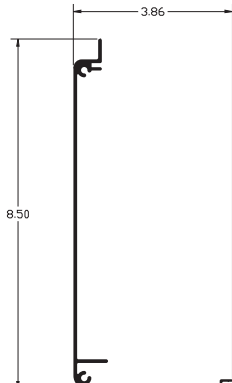

2 Piece Transformer Raceway-Back

ITEM NO. SC1982

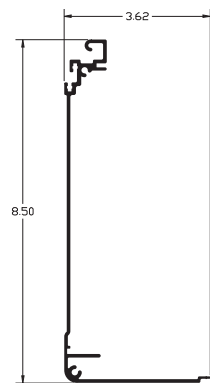

Transformer Raceway Mounting Clip

ITEM NO. SC1989

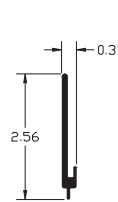

Transformer Raceway Large Mounting Clip

ITEM NO. SC1989

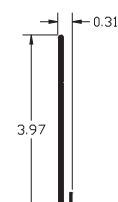

Transformer Raceway Cover

item no. SC1986

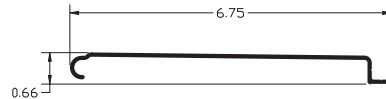

Wall Frames



3/4" Wall Frame

(clear anodized)

ITEM NO. SC1948

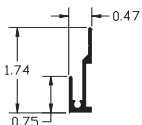

3/4" Wall Frame

(clear anodized)

ITEM NO. SC1949

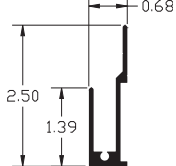

Standard Molding



1-3/8" L-Molding

ITEM NO. SC1943

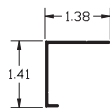

1" H-Molding

ITEM NO. SC1945

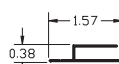

1" Z-Molding

ITEM NO. SC1946

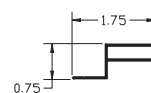

1.5" Z-Molding

ITEM NO. SC1947

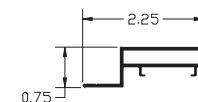

Snap Frame Kits



KIT INCLUDES:

- Four (4) pieces of cut to size and mitered Snap Frame and Snap Frame Covers.
- Four (4) Corner Keys with Set Screws.
- Spring Clips

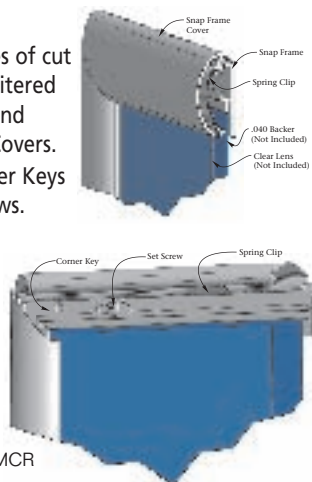

ITEM NO. SCSFMCR

Edge Lit LED Extrusions

Mill Finish

Edge Lit LED

1/4" round

ITEM NO. SC1996

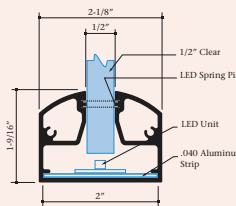

Edge Lit LED

1/2" round

ITEM NO. SC1995

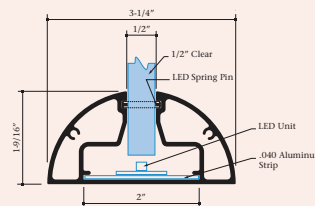

Edge Lit is sold in kits which include extrusion, side end caps & pins. Available in any width size from 12" up to 96"



SignComp Extrusion

Components for Standard Extrusion

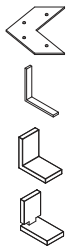

ITEM NO.	DESCRIPTION
SC5210	Corner Key
SC5975	2Part Outer Frame Corner Angle
SC5305	Frame Corner Angle
SC5300	Divider Corner Angle

Body Corner Angle

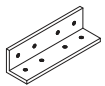

ITEM NO.	DESCRIPTION
SC5977	1Part 2Part 12" Body Corner Angle
SC5978	1Part 2Part 9" Body Corner Angle
SC5979	1Part 2Part 8" S/F Body Corner Angle
SC5981	1Part 2Part 6" S/F Body Corner Angle

Body Ballast Pan

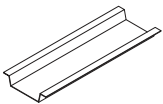

ITEM NO.	DESCRIPTION
SC5970	1Part 2Part 12" Body Ballast Pan
SC5971	1Part 2Part 9" Body Ballast Pan
SC59	1Part 2Part 8" S/F Body Ballast Pan
SC5969	1Part 2Part 6" S/F Body Ballast Pan

Edge Lit LED Round Cap

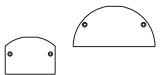

ITEM NO.	DESCRIPTION
SC5905	Edge Lit LED 1/2" Round Cap
SC5903	Edge Lit LED 1/4" Round Cap

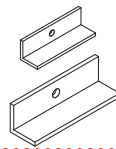

Channel Letter Raceway Lifting Bracket

ITEM NO.	DESCRIPTION
SC5976-5	5" Lifting Bracket
SC5976-8	8" Lifting Bracket

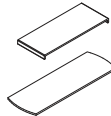

Channel Letter Raceway Brace

ITEM NO.	DESCRIPTION
SC5972-5	5" Raceway Brace/Bracket
SC5976-8	8" Raceway Brace



Channel Letter Raceway Mounting Clip

ITEM NO.	DESCRIPTION
SC5989	3" Mounting Clip
SC5988	3" Large Mounting Clip



Channel Letter Raceway End Cap

ITEM NO.	DESCRIPTION
SC5987-5	5" End Cap
SC5987-8	8" End Cap

Body Raceway Cover

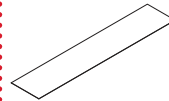

ITEM NO.	DESCRIPTION
SC5984B-12	1Part 2Part 12" Body Raceway Cover
SC5984B-9	1Part 2Part 9" Body Raceway Cover
SC5984B-8	1Part 2Part 8" S/F Body Raceway Cover
SC5984B-6	1Part 2Part 6" S/F Body Raceway Cover

Hardware for Standard Extrusion

Hinge

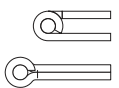

ITEM NO.	DESCRIPTION
SC5996	2Part Hinge
SC5997	2Part Large Hinge

Screws

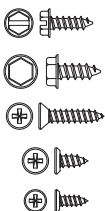

ITEM NO.	DESCRIPTION
SC5290	2Part Retainer Screw, Raceway Cover Screw
SC5218	1Part/2Part Corner Angle Screw
SC5241	2Part Ext. Retainer Corner Screw, Wall Frame Corner Screw
SC5990	2Part Outer Frame Corner Angle Screw
SC5940	LED Cap Screw

LED Spring Pin



ITEM NO.	DESCRIPTION
SC5945	LED Spring Pin

Locks for Standard Extrusion

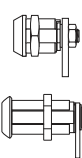

ITEM NO.	DESCRIPTION
SC5994	2Part Lock
SC5993	2Part Large Lock
SC5992	2Part Lock Wrench

SignComp Extrusion

Commercial Extrusion

Sign Cabinet Bodies

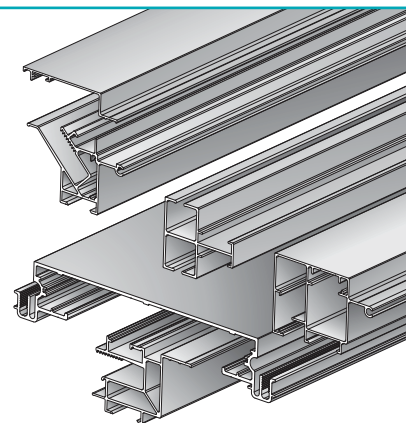
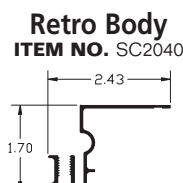
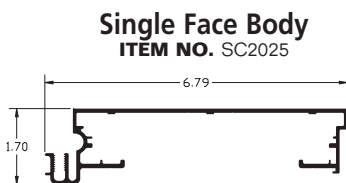
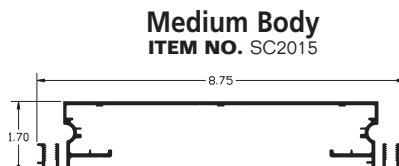
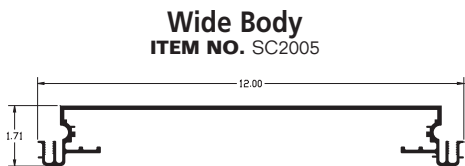

Hingeable Retainers



For Rigid Plastic Faces

1-1/2" Retainer
ITEM NO. SC2055

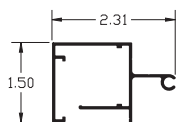

2-1/4" Retainer
ITEM NO. SC2045

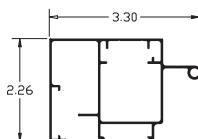

For Rigid Plastic or Flexible Fabric Faces

Dual Frame
ITEM NO. SC2065

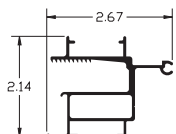

2-1/4" Dual Frame Cover
ITEM NO. SC2075

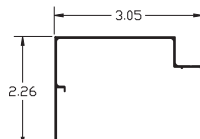

For Flexible Fabric Faces

Tension Frame
ITEM NO. SC2085

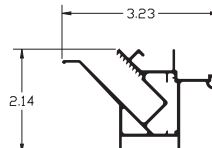

Bleed Tension Frame Cover
ITEM NO. SC2095

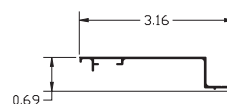

1-1/2" Tension Frame Cover
ITEM NO. SC2084

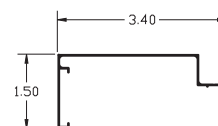

Divider Bars



For Rigid Plastic Faces

2" Divider
ITEM NO. SC2138

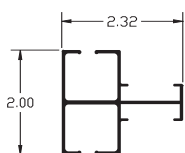

2-3/4" Divider
ITEM NO. SC2128

For Flexible Fabric and/or Rigid Plastic Faces

Dual Divider
ITEM NO. SC2142

2-1/2" Dual Divider Cover
ITEM NO. SC2146

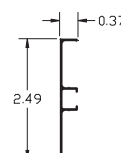

SignComp Extrusion

Commercial Extrusion

Retro Frame Systems
For Flexible Fabric Faces



Bleed Retro Frame
ITEM NO. SC2105

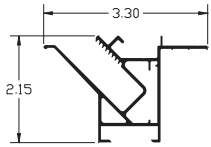

Bleed Retro Frame Cover
ITEM NO. SC2122

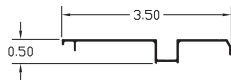

Flat Bleed Retro Frame
ITEM NO. SC2104

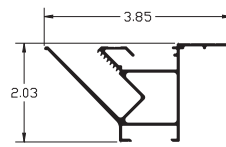

Flat Bleed Retro Frame Cover
ITEM NO. SC2121

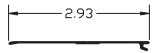

Extended Bleed Retro Cover
ITEM NO. SC2123

1-1/2" Flat Retro Frame Cover
ITEM NO. SC2125

2" Retro Frame
ITEM NO. SC2138

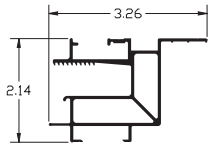

2-3/8" Retro Frame Cover
ITEM NO. SC2138

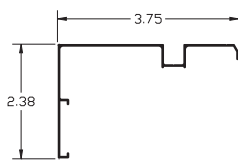

Wall Mount Retro Frame
ITEM NO. SC2090

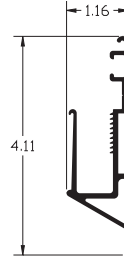

Wall Mount Retro Frame Cover
ITEM NO. SC2091

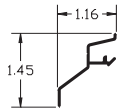

Wall Mount Retro Square Cover
ITEM NO. SC2088

Wall Mount Retro Radius Cover
ITEM NO. SC2089

Retro Fascia Systems
For Flexible Fabric Faces



Bleed Fascia Frame
ITEM NO. SC2092

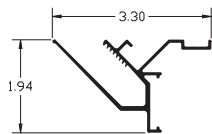

1-1/2" Fascia Frame
ITEM NO. SC2094

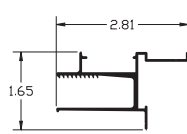

Tension Clip System



Tension Clip
ITEM NO. SC5360

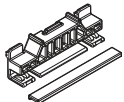

Tensioning Tool
ITEM NO. SC5135



Wall Mount Tensioning Tool
ITEM NO. SC5137

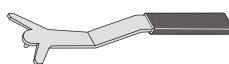

Architectural Extrusion



Architectural System Examples

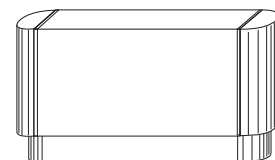
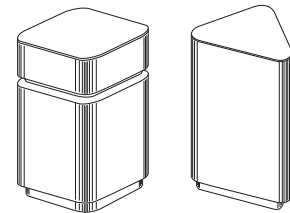
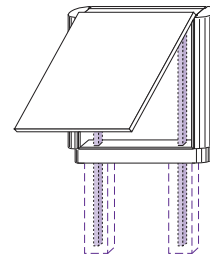
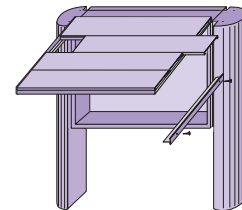

For more information, please consult with your sales rep.



www.sfsupplies.com



INDEX

➤ DIGITAL MEDIA	5
➤ SIGN VINYL	45
➤ VINYL AND WRAP SUPPLIES	59
➤ WIDE FORMAT EQUIPMENT	73
➤ VINYL CUTTERS	87
➤ ENGRAVERS	95
➤ SOFTWARE	97
➤ SUBSTRATES	105
➤ BANNER	127
➤ SIGN DISPLAY	139
➤ TAPES & ADHESIVES	145
➤ PAINT	153
➤ NEON SUPPLIES & EQUIPMENT	167
➤ TRANSFORMERS	207
➤ LED SYSTEMS	229
➤ LIGHTING & ELECTRIC	243
➤ SIGN EXTRUSION	267
➤ LETTER & ACCESSORIES	277
➤ MOUNTING HARDWARE	281
➤ EQUIPMENT & SHOP TOOLS	293

Aluminum

Plastic Trim

Plastic trims are used for acrylic cut letters or channel letters. 1" & 2" rolls are 150' long and are also sold per 10 foot lengths. 3/4" rolls are 200'. Sold by roll only.

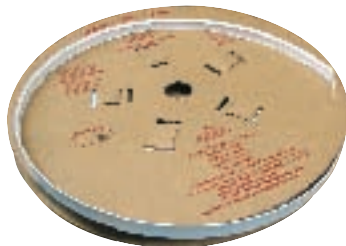
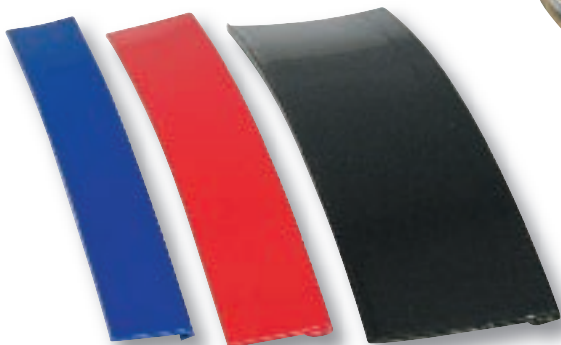

1" Plastic Trim

ITEM NO.	COLOR
PCT1BKR	Black
PCT1BLR	Blue
PCT1BZR	Bronze
PCT1BRR	Brown
PCT1BUR	Burgundy
PCT1DGRR	Dove Gray
PCT1FGR	Forest Green
PCT1GOR	Gold
PCT1GRR	Green
PCT1IR	Ivory
PCT1MGR	Metallic Gray
PCT1MSR	Metallic Silver
PCT1OR	Orange
PCT1PIR	Pink
PCT1PUR	Purple
PCT1RR	Red
PCT1SSR	Satin Silver
PCT1SR	Silver
PCT1SKBLR	Sky Blue
PCT1TR	Teal
PCT1WR	White
PCT1YR	Yellow

3/4" Plastic Trim

ITEM NO.	COLOR
PCT34BK	Black
PCT34BL	Blue
PCT34BZ	Bronze
PCT34BR	Brown
PCT34FGR	Forest Green
PCT34G	Gold
PCT34GR	Green
PCT34I	Ivory
PCT34MG	Metallic Gray
PCT34O	Orange
PCT34R	Red
PCT34SS	Satin Silver
PCT34S	Silver
PCT34W	White
PCT34Y	Yellow



2" Plastic Trim

ITEM NO.	COLOR
PCT2BKR	Black
PCT2BLR	Blue
PCT2GOR	Gold
PCT2GRR	Green
PCT2RR	Red
PCT2SR	Silver
PCT2WR	White
PCT2YR	Yellow

Neonlite Plastic Trim

Neonlite is a fascinating 1-1/2" trim with a 3/8" clear section in the middle. When mounted it imparts a "halo" effect to your trademark, with the appearance of neon but without the maintenance costs of neon. Rolls are 150' long.

1 1/2" Neonlite Plastic Trim

ITEM NO.	COLOR
PCTNCH	Chrome
PCTNG	Gold



Aluminum Studs

100 per pack



ITEM NO.	SIZE
HDAST14202	1/4-20 x 2"
HDAST14203	1/4-20 x 3"
HDAST14204	1/4-20 x 4"
HDAST14205	1/4-20 x 5"
HDAST14206	1/4-20 x 6"
HDAST10241	10/24 (3/16") x 1"
HDAST10242	10/24 (3/16") x 2"
HDAST10243	10/24 (3/16") x 3"
HDAST10244	10/24 (3/16") x 4"
HDAST10245	10/24 (3/16") x 5"
HDAST10246	10/24 (3/16") x 6"

Acrylic Blocks

Available large and small. For 10/24 (3/16") studs.



ITEM NO.	SIZE	PACK
PCPBLL	1/2" x 1" x 1-1/4"	50
PCPBLS	1/2" x 1/2" x 3/4"	100

Clear Mounting Pads

Available large and small. For 10/24 (3/16") studs.



ITEM NO.	SIZE	PACK
PCPMP112	1-1/2"	50
PCPMP212	2-1/2"	25

Plastic Spacers



ITEM NO.	SIZE	PACK
PCPSP1	1"	100
PCPSP12	1/2"	100
PCPSP34	3/4"	100

Plastic Square Rod

ITEM NO.	SIZE
PCSQR18	1/8" x 1/8" x 6'
PCSQR316	3/16" x 3/16" x 6'
PCSQR14	1/4" x 1/4" x 6'

Price Tag Molding

Plastic flat back price tag molding with adhesive backing.



ITEM NO.	SIZE	COLOR
PCPTM112C	1½" x 48"	Clear
PCPTM112W	1½" x 48"	White
PCPTM2C	2" x 48"	Clear
PCPTM2W	2" x 48"	White

Frame Strips

Frame Strips are simple to use. Two channels per strip, scored in the center, snap apart easily upon folding in half and removing the protective adhesive liner from the back.



ITEM NO.	SIZE	COLOR
PCFSWH24	24"	White
PCFSBK24	24"	Black
PCFSCL24	24"	Clear
PCFSCL48	48"	Clear

Plastic J Molding

Plastic J Molding with adhesive backing.



ITEM NO.	SIZE	COLOR
PCJC48	48"	Clear

Plastic Divider

Fits 1/8"

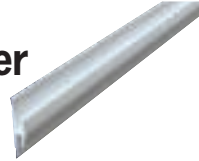

ITEM NO.	SIZE	COLOR
PCDBK96	96"	Black
PCDW48	96"	White

Pronto PLastic Letter Tracks

10' Length



ITEM NO.	DESCRIPTION	COLOR
LPTB10	Bottom Track (1-7/8")	Clear
LPTD10	Dual Track	Clear
LPTT10	Top Track (2-1/8")	Clear

Plastic Capping

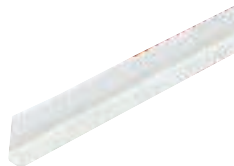

ITEM NO.	SIZE	COLOR
PCCW48	96" (fits 1/8")	White

Roper Whitney Hand Notchers



ITEM NO.	DESCRIPTION
HD141	No. 141 Portable Notcher
HD541	No. 541 Series 90° Hand Notcher w/90° Blade Set
HD542	No. 542 Series 45° Hand Notcher w/45° Blade & Die

Plastic Trim Nicker

Notch letter trim like a pro with the "Nicker". The "Nicker" works equally well with all widths of trim from 3/4" to 2" leaving a uniform cut time after time, which allows for a smooth, uniform bend.



ITEM NO.	DESCRIPTION
PCKN	Plastic Trim Nicker
PCKNRB	Replacement Blade

Foam Rubber



ITEM NO.	THICKNESS	SIZE	COLOR
FR1B	1"	37"x72"	Black
FR1W	1"	37"x72"	White
FR112B	1-1/2"	37"x72"	Black
FR112W	1-1/2"	37"x72"	White

Sandwich Magnet

Can be used on steel sheet to hold the trim to plexi while gluing it together.



ITEM NO.
PCMS

Resin Bond

Methylene chloride bonding material.



ITEM NO.	DESCRIPTION
PCRNBG	Gallon
PCRNBQ	Quart

Hypo Applicator

ITEM NO.	DESCRIPTION
PCAP	HYPO 25 (Blue)
PCAP35	HYPO 35 (Yellow)
PCAP49	HYPO 49 (Pink)



MAXX-BRITE Aluminum Coil

MAXX-Brite® is the most reflective channel letter



coil available, and eliminates the need for additional paints, films, L.E.D. or neon!

See page 109 for item no. and sizes



www.sfsupplies.com



INDEX

DIGITAL MEDIA	5
SIGN VINYL	45
VINYL AND WRAP SUPPLIES	59
WIDE FORMAT EQUIPMENT	73
VINYL CUTTERS	87
ENGRAVERS	95
SOFTWARE	97
SUBSTRATES	105
BANNER	127
SIGN DISPLAY	139
TAPES & ADHESIVES	145
PAINT	153
NEON SUPPLIES & EQUIPMENT	167
TRANSFORMERS	207
LED SYSTEMS	229
LIGHTING & ELECTRIC	243
SIGN EXTRUSION	267
LETTER & ACCESSORIES	277
MOUNTING HARDWARE	281
Fasteners	282-289
Sign Brackets.....	290
Sign Post	291-292
EQUIPMENT & SHOP TOOLS	293

Fasteners

SCREW HEAD SIZES: #8=1/4", #10/#12=5/16", #14=3/8"

Self Drilling Screws

Self Drilling

By drilling its own hole, Bit-Tip® produces the optimum hole size, resulting in better thread engagement and a tighter fit. One operation fastening also means no alignment problems.



Self Drilling with Neoprene Washers

Screw with washer

ITEM NO.	SIZE	PER BOX
HDSD8050WW	#8 x 1/2"	500
HDSD8075WW	#8 x 3/4"	500

Washer only

ITEM NO.	SIZE	PER BOX
HD8BNPW	#8	500

Self Drilling with Modified Truss Head



ITEM NO.	SIZE	PER BOX
HDSD8050MTH	#8 x 1/2"	500
HDSD8075MTH	#8 x 3/4"	500

Self Drilling Stainless Steel

ITEM NO.	SIZE	PER BOX
HDSD8050SS	#8 x 1/2"	500
HDSD8075SS	#8 x 3/4"	500

Poly Caps

ITEM NO. HD8PCW



Dome Caps

ITEM NO. HD8HDCW



Machine Screws



ITEM NO.	SIZE	PER BOX
HDMS14050	1/4-20 x 1/2"	100
HDMS14075	1/4-20 x 3/4"	100
HDMS14100	1/4-20 x 1"	100
HDMS14112	1/4-20 x 1 1/2"	100
HDMS14200	1/4-20 x 2"	100
HDMS14250	1/4-20 x 2 1/2"	100
HDMS14300	1/4-20 x 3"	100
HDMS14400	1/4-20 x 4"	100
HDMS14500	1/4-20 x 5"	100

Tap Bolts



ITEM NO.	SIZE	PER BOX
HDTB38100	3/8 x 1"	50
HDTB38150	3/8 x 1 1/2"	50
HDTB38200	3/8 x 2"	50
HDTB38250	3/8 x 2 1/2"	50
HDTB38300	3/8 x 3"	50
HDTB38400	3/8 x 4"	50
HDTB38500	3/8 x 5"	50
HDTB38600	3/8 x 6"	50
HDTB12300	1/2 x 3"	50
HDTB14075	1/4-20 x 3/4"	100

Self Piercing Screws

Self Piercing

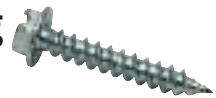

ITEM NO.	SIZE	PER BOX
HDSP8050	#8 x 1/2"	1000
HDSP8075	#8 x 3/4"	500
HDSP8100	#8 x 1"	500
HDSP8150	#8 x 1-1/2"	100
HDSP8200	#8 x 2"	100

Self Piercing Painted



ITEM NO.	COLOR	SIZE	BOX
HDSP8050BK	BLACK	#8 x 1/2"	500
HDSP8050BZ	BRONZE	#8 x 1/2"	500
HDSP8050WH	WHITE	#8 x 1/2"	500

Sheet Metal Screws

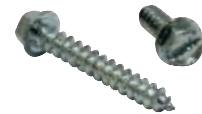

ITEM NO.	SIZE	PER BOX
HDSM10050	#10 x 1/2"	500
HDSM10075	#10 x 3/4"	500
HDSM10100	#10 x 1"	100
HDSM10150	#10 x 1 1/2"	100
HDSM10200	#10 x 2"	100
HDSM10250	#10 x 2 1/2"	100
HDSM10300	#10 x 3"	100
HDSM12050	#12 x 1/2"	500
HDSM12075	#12 x 3/4"	500
HDSM12100	#12 x 1"	100
HDSM12150	#12 x 1 1/2"	100
HDSM12200	#12 x 2"	100
HDSM12250	#12 x 2 1/2"	100
HDSM12300	#12 x 3"	100
HDSM14075	#14 x 3/4"	500
HDSM14100	#14 x 1"	100
HDSM14150	#14 x 1 1/2"	100
HDSM14200	#14 x 2"	100
HDSM14250	#14 x 2 1/2"	100
HDSM14300	#14 x 3"	100
HDSM14400	#14 x 4"	50

Fasteners

Lag Bolts



ITEM NO.	SIZE	PER BOX
HDLB516100	5/16 x 1"	100
HDLB516600	5/16 x 6"	25
HDLB516150	5/16 x 1½"	50
HDLB516200	5/16 x 2"	50
HDLB516250	5/16 x 2½"	50
HDLB516300	5/16 x 3"	50
HDLB516400	5/16 x 4"	50
HDLB38100	3/8-7" x 1"	50
HDLB38150	3/8-7" x 1½"	50
HDLB38200	3/8-7" x 2"	50
HDLB38250	3/8-7" x 2½"	50
HDLB38300	3/8-7" x 3"	50
HDLB38400	3/8-7" x 4"	50
HDLB38500	3/8-7" x 5"	50
HDLB38600	3/8-7" x 6"	25
HDLB38700	3/8-7" x 7"	25
HDLB12300	1/2 x 3"	25
HDLB12400	1/2 x 4"	25
HDLB12500	1/2 x 5"	25
HDLB12600	1/2 x 6"	25

Lag Shields



ITEM NO.	SIZE	PER BOX
HDL514L	1/4" Long	50
HDL514S	1/4" Short	50
HDL516L	5/16" Long	100
HDL516S	5/16" Short	100
HDL538L	3/8" Long	50
HDL538S	3/8" Short	50
HDL512L	1/2" Long	25
HDL512S	1/2" Short	25

Fender Washer

1/4" x 1-1/4" O.D.



ITEM NO.	BOX
HDWF14	100
HDWF14BK	50 LB.

Flat Washer



ITEM NO.	SIZE	BOX
HDW14BK	1/4"	50 LB. (7350 pcs)
HDW516BK	5/16"	50 LB. (4500 pcs)
HDW12BK	1/2"	50/LB. (1,300 pcs.)
HDW38BK	3/8-16"	50 lb. (3350 pcs)
HDW14	1/4"	100
HDW516	5/16"	100
HDW38	3/8"	100
HDW12	1/2"	100
HDW58	5/8"	100
HDW8	#8	500

Lock Washer



ITEM NO.	SIZE	BOX
HDWL516	5/16"	100
HDWL38BK	3/8"	Per/M

Hex Nuts



ITEM NO.	SIZE	BOX
HDN14	1/4-20"	100
HDN516	5/16"	100
HDN38	3/8-16"	100

Aluminum Nuts



ITEM NO.	SIZE	BOX
HDAN1024	10/24"	100

Stock up on all your fasteners needs.

All types of screw, nuts, washers etc. are available in bulk boxed and are sold priced per M.



Buy Bulk & Save

Nail Anchors



ITEM NO.	SIZE	PER BOX
HDNA14100	1/4" x 1"	100
HDNA14150	1/4" x 1½"	100
HDNA14125	1/4" x 1¼"	100
HDNA14200	1/4" x 2"	100
HDNA14250	1/4" x 2½"	100
HDNA14300	1/4" x 3"	100

Concrete Screws



ITEM NO.	SIZE	PER BOX
HDCS14125	1/4" x 1¼"	100
HDCS14175	1/4" x 1¾"	100
HDCS14225	1/4" x 2¼"	100
HDCS14275	1/4" x 2¾"	100
HDCS14325	1/4" x 3¼"	100
HDCS14375	1/4" x 3¾"	100
HDCS14400	1/4" x 4"	100
HDCS14500	1/4" x 5"	100

Expert Technical Support

Need help selecting the best product to meet your sign, display or banner design? Our "signology" experts will be happy to provide you with clear, concise answers – just ask!



Fasteners

Selecting the Correct Rivet

We offer a full line of headed rivets for general consumer and industrial applications. The materials and manufacturing processes used to head rivet bodies increase their shear and tensile values over a stamped eyelet-style rivet. These easy-to-use rivets are used to fasten together two or more pieces of material of varying thickness.

The rivet body alloy, in addition to being chosen for strength requirements, should also be selected for compatibility with the materials to be joined to avoid galvanic corrosion caused by coupling dissimilar metals. If dissimilar metals are widely separated on the galvanic chart, it is advisable to separate them with a dielectric material such as paint or other coating.

Rivet Head Styles



Buttonhead

- Low profile head diameter is twice the rivet body diameter, providing adequate bearing surface for nearly all applications.
- Open-end buttonhead rivets offer the broadest selection of sizes available.

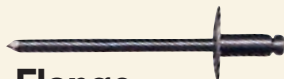

Large Flange

- Provides greater bearing surface for fastening soft and brittle facing materials and oversize facing holes.
- Works well with soft materials, where the increased flange diameter protects the integrity of the application.



Countersunk

Available as special order

- 120° countersunk rivets for applications where flush appearance is required.

Aluminum Rivets

- 5052 Aluminum Rivet
- Aluminum Mandrel
- IFI grade 11

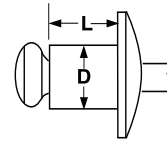

ITEM #	RIVET DIAMETER INCH (MM)	DRILL NO. & HOLE SIZE	RIVET LGH MAX. INCH (MM)	GRIP RANGE	QTY PER BOX
--------	--------------------------	-----------------------	--------------------------	------------	-------------

Buttonhead

HDRAA42	1/8" (3.2)	#30 (.129-.133)	.275 (7.0)	.063-.125	500,1M,10M
HDRAA44			.400 (10.2)	.188-.250	500,1M,10M
HDRAA46			.525 (13.4)	.313-.375	500,10M
HDRAA48			.650 (16.5)	.376-.500	
HDRAA52	5/32" (4.0)	#20 (.160-.164)	.300 (7.6)	.062-.125	500,8M
HDRAA53			.362 (9.2)	.126-.187	500,8M
HDRAA54			.425 (10.8)	.188-.250	8M
HDRAA56			.550 (14.0)	.251-.375	
HDRAA58			.675 (17.2)	.376-.500	
HDRAA62	3/16" (4.8)	#11 (.192-.196)	.325 (8.3)	.062-.125	500,5M
HDRAA64			.450 (11.5)	.126-.250	500,5M
HDRAA66			.575 (14.6)	.251-.375	500,5M
HDRAA68			.700 (17.8)	.376-.500	250,4M
HDRAA84	1/4" (6.4)	F (.257-.261)	.500 (12.7)	.062-.250	
HDRAA86			.625 (15.9)	.251-.375	
HDRAA88			.750 (19.1)	.376-.500	

Large Flange

HDRAA42ALF	1/8" (.125)	#30 (.129-.133)	.275 (7.0)	.032-.125	500,10M
HDRAA44ALF			.400 (10.2)	.188-.250	500,10M
HDRAA46ALF			.525 (13.3)	.251-.375	
HDRAA48ALF			.650 (16.5)	.376-.500	
HDRAA54ALF	5/32" (.156)	#20 (.160-.164)	.425 (10.8)	.063-.250	
HDRAA64ALF	3/16" (.187)	#11 (.192-.196)	.450 (11.5)	.062-.250	
HDRAA66ALF			.575 (14.6)	.251-.375	
HDRAA68ALF			.700 (17.8)	.376-.500	

Painted Aluminum Rivets



ITEM NO.	SIZE/COLOR	QTY
HDRAA42W	AA42 White	500,10M
HDRAA42BK	AA42 Black	500,10M
HDRAA42BZ	AA42 Bronze	500,10M
HDRAA44W	AA44 White	500,10M
HDRAA44BK	AA44 Black	500,10M
HDRAA44BZ	AA44 Bronze	500,10M

For other sizes or custom colors, please contact your sales rep.

**For Rivet Guns
see page 298**



Steel Rivets

- Plated-Steel Rivet
- Coated Steel Mandrel
- IFI Grade 30

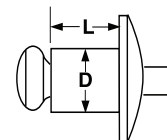

ITEM #	RIVET DIAMETER INCH (MM)	DRILL NO. & HOLE SIZE	RIVET LGH MAX. INCH (MM)	GRIP RANGE	QTY PER BOX
Buttonhead					
HDRSS42	1/8" (.125)	#30 (.129-.133)	.275 (7.0)	.063-.125	500,10M
HDRSS44			.400 (10.2)	.188-.250	500,10M
HDRSS46			.525 (13.4)	.313-.375	1M,10M
HDRSS48			.650 (16.5)	.376-.500	
HDRSS52	5/32" (.156)	#20 (.160-.164)	.300 (7.6)	.062-.125	
HDRSS53			.362 (9.2)	.126-.187	
HDRSS54			.425 (10.8)	.188-.250	
HDRSS56			.550 (14.0)	.251-.375	
HDRSS58			.675 (17.2)	.376-.500	
HDRSS62	3/16" (.187)	#11 (.192-.196)	.325 (8.3)	.062-.125	5M
HDRSS64			.450 (11.5)	.126-.250	500,5M
HDRSS66			.575 (14.6)	.251-.375	
HDRSS68			.700 (17.8)	.376-.500	
HDRSS82	1/4" (.250)	F (.257-.261)	.370 (9.4)	.062-.125	
HDRSS84			.500 (12.7)	.062-.250	
HDRSS86			.625 (15.9)	.251-.375	
HDRSS88			.750 (19.1)	.376-.500	

Large Flange

HDRSS42LF	1/8" (.125)	#30 (.129-.133)	.275 (7.0)	.032-.125	500,10M
HDRSS44LF			.400 (10.2)	.88-.250	500,10M
HDRSS46LF			.525 (13.3)	.251-.375	
HDRSS48LF			.650 (16.5)	.376-.500	
HDRSS54LF	5/32" (.156)	#20 (.160-.164)	.425 (10.8)	.188-.250	
HDRSS56LF			.550 (14.0)	.251-.375	
HDRSS58LF			.675 (17.2)	.376-.500	
HDRSS64LF	3/16" (.187)	#11 (.192-.196)	.450 (11.5)	.062-.250	
HDRSS66LF			.575 (14.6)	.251-.375	
HDRSS68LF			.700 (17.8)	.376-.500	

Painted Steel Rivets



ITEM NO.	SIZE/COLOR	QTY
HDRSS42BK	SS42 Black	500
HDRSS44BK	SS44 Black	500
HDRSS42BZ	SS42 Bronze	500
HDRSS44BZ	SS44 Bronze	500
HDRSS42W	SS42 White	500
HDRSS44W	SS44 White	500

For other sizes or custom colors, please contact your sales rep.

Fasteners

Available Rivet Types



Open End

- For blind fastening where there is no access to opposite side of work
- Wide variety of head styles and lengths available from 3/32" to 1/4" diameters

Available in Steel/steel,

Aluminum/aluminum, Aluminum/steel,

Stainless/stainless, Stainless/steel,

Copper/brass, Copper/steel



Closed End

- Moisture-resistant due to tight seal
- Greater shear and tensile strength
- Mandrel is retained 100% of time
- 1/8" to 1/4" diameters

Available in Aluminum/aluminum,

Aluminum/steel, Stainless/stainless



Multi-Grip

- Extended grip range capacity
- Reduces inventory (fewer sizes required)
- Use as a standard open end rivet
- No special tools required
- 1/8" to 3/16" diameters

Available in Aluminum/steel, Steel/Steel



Q-Lok

- Retained mandrel increases shear and tensile strength
- Use in high vibration applications
- Mandrel breaks flush when used in mid-grip range
- Moisture-resistant due to tight seal
- 1/8" to 3/16" diameters

Available in Steel/Steel



Klik-Lock

- Permanently retained mandrel provides increased shear and tensile values
- Use in high vibration applications
- Provides weather-resistant joint
- Available in 3/16" and 1/4" diameters

Available in Steel/Steel,

Aluminum/aluminum, Stainless/stainless



T-Rivets

- High clamp up
- High shear strength
- Creates a wide bearing surface
- 1/4" diameter

Available in Aluminum/steel



Plastic

- Precision-molded, all-nylon
- Secure lock prevents pull-out
- Fasten plastic to plastic, plastic to metal or plastic to fiberglass

Stainless Rivets

- Stainless Rivet
- Stainless Mandrel
- IFI Grade 51

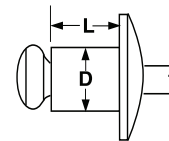

ITEM #	RIVET DIAMETER INCH (MM)	DRILL NO. & HOLE SIZE	RIVET LGH MAX. INCH (MM)	GRIP RANGE	QTY PER BOX
Buttonhead					
HDRSTST42	1/8" (.125)	#30 (.129-.133)	.275 (7.0)	.063-.125	500,10M
HDRSTST44			.400 (10.2)	.188-.250	500,10M
HDRSTST46			.525 (13.4)	.313-.375	
HDRSTST48			.650 (16.5)	.376-.500	
HDRSTST52	5/32" (.156)	#20 (.160-.164)	.300 (7.6)	.062-.125	
HDRSTST53			.338 (8.0)	.126-.187	
HDRSTST54			.425 (10.8)	.188-.250	
HDRSTST56			.550 (14.0)	.251-.375	
HDRSTST58			.675 (17.2)	.376-.500	
HDRSTST62	3/16" (.187)	#11 (.192-.196)	.325 (8.3)	.062-.125	
HDRSTST64			.450 (11.5)	.126-.250	
HDRSTST66			.575 (14.6)	.251-.375	
HDRSTST68			.700 (17.8)	.376-.500	
HDRSTST84	1/4" (.250)	F (.257-.261)	.500 (12.7)	.062-.250	
HDRSTST86			.625 (15.9)	.251-.375	
HDRSTST88			.750 (19.1)	.376-.500	
Large Flange					
HDRSTST42LF	1/8" (.125)	#30 (.129-.133)	.275 (7.0)	.032-.125	
HDRSTST43LF			.337 (8.6)	.126-.187	
HDRSTST44LF			.400 (10.2)	.188-.250	
HDRSTST64LF	3/16" (.187)	#11 (.192-.196)	.450 (11.5)	.062-.250	
HDRSTST66LF			.575 (14.6)	.251-.375	
HDRSTST68LF			.700 (17.8)	.376-.500	
HDRSTST610LF			.825 (21.0)	.501-.625	
HDRSTST612LF			.950 (24.2)	.626-.750	



Eyebolts with Nuts

Standard Style, Extra long style.

Machine thread hex nut, zinc chromate finish. All eyebolts are provided with hex nuts assembled for your convenience.

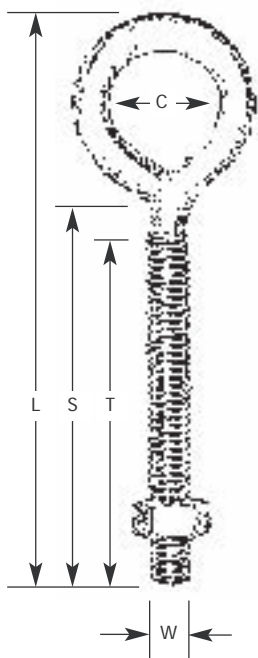

ITEM NO.	PART#	L	S	T	C	W	WIRE DIA.	PER BOX
Small Eye								
HDEB362	10706	2"	1 ⁵ / ₁₆ "	1 ⁵ / ₁₆ "	5/16"	10-24	.160	20
Regular Eye								
HDEB316134	10769	1 ³ / ₄ "	1"	7/8"	3/8"	10-24	.160	20
HDEB316214	10771	2 ¹ / ₄ "	1 ¹ / ₂ "	1 ³ / ₈ "	3/8"	10-24	.160	20
HDEB316212	10772	2 ¹ / ₂ "	1 ³ / ₄ "	1 ⁵ / ₈ "	3/8"	10-24	.160	20
HDEB316234	10773	2 ³ / ₄ "	2"	1 ⁷ / ₈ "	3/8"	10-24	.160	20
HDEB3163	10774	3"	2 ¹ / ₄ "	2 ¹ / ₈ "	3/8"	10-24	.160	20
HDEB142	10800	2"	1"	7/8"	9/16"	1/4-20	.214	20
HDEB14212	10802	2 ¹ / ₂ "	1 ¹ / ₂ "	1 ³ / ₈ "	9/16"	1/4-20	.214	20
HDEB143	10803	3"	2"	1 ³ / ₄ "	9/16"	1/4-20	.214	20
HDEB144	10805	4"	3"	2 ³ / ₄ "	9/16"	1/4-20	.214	20
HDEB145	10807	5"	4"	3"	9/16"	1/4-20	.214	20
HDEB146*	10808	6"	5"	3"	9/16"	1/4-20	.214	20
HDEB148*	10810	8"	7"	3"	9/16"	1/4-20	.214	20
HDEB516214	10836	2 ¹ / ₄ "	3/4"	1/2"	3/4"	5/16-18	.272	10
HDEB516314	10839	3 ¹ / ₄ "	1 ³ / ₄ "	1 ¹ / ₂ "	3/4"	5/16-18	.272	10
HDEB5164	10841	4"	2 ¹ / ₂ "	2 ¹ / ₄ "	3/4"	5/16-18	.272	10
HDEB5165	10843	5"	3 ¹ / ₂ "	3"	3/4"	5/16-18	.272	10
HDEB5166	10845	6"	4 ¹ / ₂ "	3"	3/4"	5/16-18	.272	10
HDEB5168*	10849	8"	6 ¹ / ₂ "	3"	3/4"	5/16-18	.272	10
HDEB38212	10873	2 ¹ / ₂ "	3/4"	1/2"	1"	3/8-16	.331	10
HDEB383	10874	3"						
HDEB384	10875	4"	2 ¹ / ₄ "	2"	1"	3/8-16	.331	10
HDEB385	10877	5"	3 ¹ / ₄ "	3"	1"	3/8-16	.331	10
HDEB386	10878	6"	4 ¹ / ₄ "	3"	1"	3/8-16	.331	10
HDEB388	10880	8"	6 ¹ / ₄ "	3 ⁷ / ₈ "	1"	3/8-16	.331	10
HDEB7168*	10907	8"	6"	3"	1 ¹ / ₈ "	7/16-14	.380	10
HDEB124	10932	4"	1 ³ / ₄ "	1 ¹ / ₄ "	1 ¹ / ₄ "	1/2-13	.445	10
HDEB126	10934	6"	3 ³ / ₄ "	3"	1 ¹ / ₄ "	1/2-13	.445	10
HDEB128	10936	8"	5 ³ / ₄ "	3 ⁷ / ₈ "	1 ¹ / ₄ "	1/2-13	.445	10
HDEB1210	10938	10"	7 ³ / ₄ "	3 ⁷ / ₈ "	1 ¹ / ₄ "	1/2-13	.445	10
HDEB1212*	10940	12"	9 ³ / ₄ "	3 ⁷ / ₈ "	1 ¹ / ₄ "	1/2-13	.445	10
Welded Eye								
HDEBW14212	13802	2 ¹ / ₂ "	1 ¹ / ₂ "	1 ³ / ₈ "	9/16"	1/4-20	.214	10
HDEBW5164*	13841	4"	2 ¹ / ₂ "	2 ¹ / ₄ "	3/4"	5/16-18	.272	10
HDEBW5166*	13845	6"	4 ¹ / ₂ "	3"	3/4"	5/16-18	.272	10
HDEBW384	13875	4"	2 ¹ / ₄ "	2"	1"	3/8-16	.331	10
HDEBW386	13878	6"	4 ¹ / ₄ "	3"	1"	3/8-16	.331	10
HDEBW388*	13880	8"	6 ¹ / ₄ "	3 ⁷ / ₈ "	1"	3/8-16	.331	10
HDEBW126*	13934	6"	3 ³ / ₄ "	3"	1 ¹ / ₄ "	1/2-13	.445	10
HDEBW1210*	13938	10"	7 ³ / ₄ "	3 ⁷ / ₈ "	1 ¹ / ₄ "	1/2-13	.445	10

Available as a special order

Fasteners

Lag Thread Eye Bolt

Zinc Chromate finish

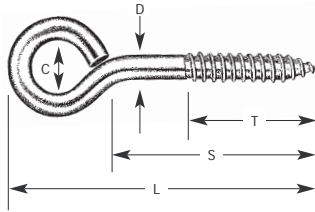

ITEM NO.	PART#	L	S	T	C	D	PER BOX
HDEBL3163*	11090	3	2 ³ / ₁₆ "	1 ¹ / ₈ "	3 ³ / ₈ "	.177	20
HDEBL14334*	11101	3 ³ / ₄ "	2 ³ / ₄ "	1 ³ / ₄ "	1 ¹ / ₂ "	.244	20
HDEBL154*	11103	5	4"	1 ¹ / ₈ "	1 ¹ / ₂ "	.244	20
HDEBL5164*	11104	4	2 ³ / ₄ "	1 ³ / ₄ "	5 ⁸ / ₈ "	.307	10
HDEBL5165*	11093	5	3 ³ / ₄ "	1 ³ / ₄ "	5 ⁸ / ₈ "	.307	10
HDEBL5166*	11105	6	4 ³ / ₄ "	1 ³ / ₄ "	5 ⁸ / ₈ "	.307	10
HDEBL38412	11106	4 ¹ / ₂ "	2 ³ / ₄ "	1 ³ / ₄ "	3 ⁴ / ₄ "	.365	10
HDEBL386	11095	6	4 ¹ / ₄ "	1 ³ / ₄ "	3 ⁴ / ₄ "	.365	10
HDEBL388*	11107	8	6 ¹ / ₄ "	2 ¹ / ₈ "	3 ⁴ / ₄ "	.365	10
HDEBL716514*	11108	5 ¹ / ₄ "	3 ³ / ₄ "	2 ¹ / ₂ "	1"	.445	10

Screw Eye

ITEM NO.	DESCRIPTION
HDSEW2	#10005 W2
HDSEW6	#10009 W6

S-Hooks

Zinc Chromate finish

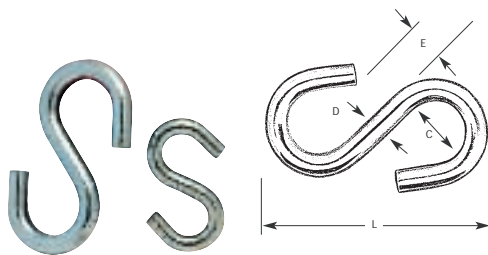

ITEM NO.	PART#	L	C	E	D	PER BOX
Heavy Open Style						
HDSH34	11715	3 ⁴ / ₄ "	3 ¹ / ₁₆ "	3 ¹ / ₁₆ "	.092	100
HDSH1	11716	1"	1 ⁴ / ₄ "	3 ¹ / ₁₆ "	.120	100
HDSH114	11717	1 ¹ / ₄ "	3 ⁸ / ₈ "	1 ⁴ / ₄ "	.148	50
HDSH112	11718	1 ¹ / ₂ "	7 ¹ / ₁₆ "	1 ⁴ / ₄ "	.177	50
HDSH134	11719	1 ³ / ₄ "	1 ² / ₂ "	5 ¹ / ₁₆ "	.192	50
HDSH2	11720	2"	9 ¹ / ₁₆ "	3 ⁸ / ₈ "	.250	50
HDSH214	11721	2 ¹ / ₄ "	5 ⁸ / ₈ "	5 ¹ / ₁₆ "	.250	50
HDSH212	11722	2 ¹ / ₂ "	3 ⁴ / ₄ "	7 ¹ / ₁₆ "	.307	50
HDSH3	11723	3"	7 ⁸ / ₈ "	1 ² / ₂ "	.307	10
Light Open Style						
HDSH134L	11803	1 ³ / ₄ "	5 ⁸ / ₈ "	5 ¹ / ₁₆ "	.105	100
HDSH112L	11804	1 ¹ / ₂ "	1 ² / ₂ "	1 ⁴ / ₄ "	.105	100
HDSH114L	11805	1 ¹ / ₄ "	3 ⁸ / ₈ "	1 ⁴ / ₄ "	.105	100
HDSH1L	11806	1"	5 ¹ / ₁₆ "	3 ¹ / ₁₆ "	.092	100
HDSH78L	11807	7 ⁸ / ₈ "	1 ⁴ / ₄ "	3 ¹ / ₁₆ "	.092	100
HDSH34L	11808	3 ⁴ / ₄ "	1 ⁴ / ₄ "	1 ⁸ / ₈ "	.080	100

Hanging Clips

5 pack

ITEM NO. HDHC3



Quick Link Connectors

5 pack



ITEM NO.	SIZE
HDQLC14	1 ⁴ / ₄ " x 2-1 ⁸ / ₈ "
HDQLC18	1 ⁸ / ₈ " x 1-1 ⁸ / ₈ "
HDQLC36	3 ¹ / ₁₆ " x 2"

Suction Cups



ITEM NO.	SIZE	DIAMETER
LYSCSM	Small (1lb.)	1 ¹ / ₈ "
LYSCM	Medium (3lb.)	1 ³ / ₄ "
LYSCLG	Large (7lb.)	2 ³ / ₈ "

U-Bolts

Standard Style, Extra long style.

All U-Bolts are provided with hex nuts and straps assembled for your convenience. Zinc Chromate finish.

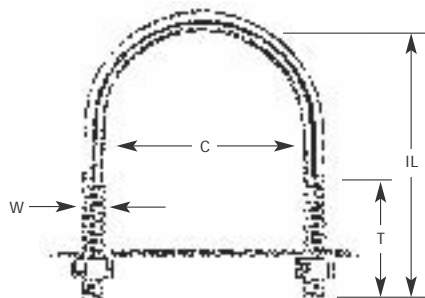

ITEM NO.	PART#	C	IL	T	FITS PIPE	WIRE DIA.	W	PER BOX
Standard Style								
HDUB14916*	11276	301	9/16"	1 3/8"	3/4"	1/4"	.214	1/4-20 10
HDUB143461*	11161	60C	3/4"	1 1/4"	3/4"	3/8"	.214	1/4-20 10
HDUB143462*	11162	61C	3/4"	1 3/4"	1"	3/8"	.214	1/4-20 10
HDUB143463*	11164	63C	3/4"	2 3/4"	2"	3/8"	.214	1/4-20 10
HDUB143465*	11166	65C	3/4"	4 3/4"	4"	3/8"	.214	1/4-20 10
HDUB141	11167	66C	1"	1 3/4"	1"	1/2"	.214	1/4-20 10
HDUB14118	11168	67C	1 1/8"	2 1/4"	1 1/2"	3/4"	.214	1/4-20 10
HDUB14138	11169	68C	1 3/8"	2 3/4"	1 3/4"	1"	.214	1/4-20 10
HDUB14134	11170	69C	1 3/4"	2 3/4"	1 1/4"	1 1/4"	.214	1/4-20 10
HDUB142	11171	70C	2"	3 1/2"	1 3/4"	1 1/2"	.214	1/4-20 10
HDUB516138	11196	80C	1 3/8"	2 1/2"	1 1/4"	1"	.272	5/16-18 10
HDUB516134	11197	82C	1 3/4"	3"	1 1/2"	1 1/4"	.272	5/16-18 10
HDUB5162	11198	84C	2"	3 3/4"	1 1/2"	1 1/2"	.272	5/16-18 10
HDUB5162*	11199	85C	2"	3 11/16"	2"	1 1/2"	.272	5/16-18 10
HDUB516212	11200	87C	2 1/2"	3 1/2"	1 1/2"	2"	.272	5/16-18 10
HDUB516212*	11201	88C	2 1/2"	4 1/6"	2 1/4"	2"	.272	5/16-18 10
HDUB382*	11226	90C	2"	3 3/8"	1 1/2"	1 1/2"	.331	3/8-16 10
HDUB38212	11227	91C	2 1/2"	3 3/8"	1 3/4"	2"	.331	3/8-16 10
HDUB383	11228	92C	3"	4 1/8"	1 3/4"	2 1/2"	.331	3/8-16 10
HDUB38312	11229	93C	3 1/2"	4 3/8"	2"	3"	.331	3/8-16 10
HDUB123*	11230	94C	3"	5"	2 1/2"	2 1/2"	.445	1/2-13 10
HDUB12312*	11231	95C	3 1/2"	5 1/2"	2 1/2"	3"	.445	1/2-13 10
HDUB124*	11232	96C	4"	6"	2 1/2"	3 1/2"	.445	1/2-13 10
HDUB12412*	11233	97C	4 1/2"	6 1/2"	2 1/2"	4"	.445	1/2-13 10
Extra Long Style								
HDUB14118L	11254	67CL	1 1/8"	3 1/2"	2 3/4"	3/4"	.214	1/4-20 10
HDUB516138L	11255	81CL	1 3/8"	3 3/4"	2 1/8"	1"	.272	5/16-18 10
HDUB516134L	11256	83CL	1 3/4"	4 1/4"	2 1/2"	1 1/4"	.272	5/16-18 10
HDUB5162L	11257	86CL	2"	4 11/16"	2 3/4"	1 1/2"	.272	5/16-18 10
HDUB516212L	11258	89CL	2 1/2"	5 1/6"	3"	2"	.272	5/16-18 10
	11260	93CL	3 1/2"	6 1/2"	3"	3"	.331	3/8-16 10

Available as a special order

Single Jack Chain

Available in Zinc Plated, Brass Plated and Black finish. Sold by roll only.

ITEM #	SIZE	FINISH
HDCSJ12ZP	#12 x 100'	Zinc Plated
HDCSJ14ZP	#14 x 100'	Zinc Plated
HDCSJ16ZP	#16 x 100'	Zinc Plated
HDCSJ18ZP	#18 x 100'	Zinc Plated
HDCSJ14BP	#14 x 100'	Brass Plated
HDCSJ16BP	#16 x 100'	Brass Plated
HDCSJ18BP	#18 x 100'	Brass Plated
HDCSJ14BK	#14 x 100'	Black



Welded Chain

Sold by foot, cut to size.

ITEM #	SIZE
HDCH18	1/8"
HDCH316	3/16"
HDCH14	1/4"



Sign Brackets

Corner Base L Bracket

- Rust resistant bright zinc plated finish
- Heavy guage steel construction
- Countersunk screw holes

ITEM NO.	SIZE
HDLBR1	1"
HDLBR112	1-1/2"
HDLBR2	2"
HDLBR212	2-1/2"
HDLBR3	3"
HDLBR312	3-1/2"
HDLBR4	4"
HDLBR5	5"
HDLBR6	6"
HDLBR8	8"
HDLBR10	10"



Flat Corner Base

100 per box.

ITEM NO.	SIZE
HDFLB112	1-1/2"



Sign Hanger

Holes are 3/8" diameter.
Galvanized.



ITEM #	SIZE	THICK	WIDE
HD6207	43"	3/16	1 1/2
HD6208	14 1/2"	3/16	1 1/2
HD6209	7 1/4" x 7 1/4"	3/16	1 1/2

Sign Mounting Brackets



ITEM NO.	DESCRIPTION
HD301	2" x 2" x 2"
HD302	2" x 2" x 4"
HD307	1-1/2" x 2" x 2"
HD306	1-1/2" x 2" x 5"

Z Hooks



ITEM NO.	DESCRIPTION
AWZH410	#410 Short
AWZH411	#411 Long

Galvanized Z Hooks

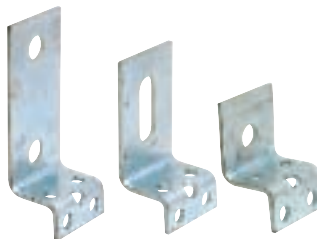

ITEM NO.	DESCRIPTION
AWZHGS	Short
AWZHGM	Medium
AWZHGL	Long

J Brackets



ITEM NO.	DESCRIPTION	SIZE
AWJB101	#101	1"
AWJB310	#310	1-1/4"
AWJB311	#311	1-3/4"

Sign Hook



ITEM #	SIZE
HDH3	3"
HDH4	4"
HDH5	5"
HDH6	6"

Sign Hanger

For Masonite, plywood, or metal swing signs. Steel - Zinc plated



ITEM #	SIZE
HDSH-12	1/2"
HDSH-34	3/4"

Galvanized U Brackets



Used to join two 1" square tubes.

ITEM NO. AWZHU

U Sign Hangers



ITEM #	SIZE
HDSHU12	1/2"
HDSHU34	3/4"

Sign Post

SG-2 SignGrabber

Designed to attach signs and banners to chain link fences. The sturdy, cast metal mounting unit fits snugly into the diamond shaped hole of most industry standard chain link fence, and with the included one-way security bolt attaches your sign or banner securely.



ITEM NO.	DESCRIPTION
SGR2	Grabber, nut, bolt



Banner Washer

Fits SG series SignGrabbers for securing banners to Chainlink.



6 per pack

ITEM NO.	DESCRIPTION
SGRBW	

SignGrabber #C2 Kit

Kit includes: 12 SG-2, 12 #P, 24 3/4" Nuts & Bolts, and 8 Banner Washers.

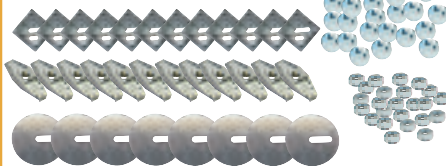

ITEM NO.	DESCRIPTION
SGRC2	

Un-Do-It Tool

For unscrewing SignGrabber Tamper Proof Bolts.



ITEM NO.	DESCRIPTION
SGRUDT	

SignGrabber #P

Designed for mounting signs to formed metal poles with regular spaced holes (u-channel and square sign posts). Used with one-way bolts they act as a non-removable nut, thus adding tamper resistance to the installation. The cast alloy used will not rust.



ITEM NO.	DESCRIPTION
SGRP	6 pack



SignGrabber #B3 Tamper Proof Bolts

5/16" x 2-1/2"



ITEM NO.	DESCRIPTION
SGRB3	6 pack

Sign Link

The perfect solution for installing signs to chain-link fences and channel sign posts. Fits all chain-link grid sizes. Sign Link is super-strong. Made from 33% glass-filled nylon. Won't rust.



ITEM NO.	DESCRIPTION
SAC-HBSL	



"U" Channel Post

2lb. per foot

ITEM NO.	SIZE	FINISH
HDUCP08GL	8"	Galvanized
HDUCP10GL	10'	Galvanized
HDUCP12GL	12'	Galvanized
HDUCP04GR	4'	Green
HDUCP05GR	5'	Green
HDUCP06GR	6'	Green
HDUCP08GR	8'	Green
HDUCP10GR	10'	Green
HDUCP12GR	12'	Green



U Channel Drive Cap

ITEM NO.	DESCRIPTION
HDUCDCJR	Junior Duty
HDUCDCMD	Medium Duty
HDUCDCHD	Heavy Duty

Post Mounting Base

15" diameter aluminum base can be mounted permanently to a concrete or a paved surface or it can be used for temporary signs. The base comes with the hardware needed to attach your post to the base. Can be used with 2lb-per-ft u-channel posts, square posts, or 2 3/8" pipe posts.



ITEM NO. HDUCPIN81

Square Fit

24'1.75" length.

ITEM NO.	GAUGE	SIZE
HDSQF112	12ga.	1"
HDSQF11214*	14ga.	1 1/2"
HDSQF11412*	12ga.	1 1/4"
HDSQF13412*	12ga.	1 3/4"
HDSQF212*	12ga.	2"
HDSQF21412*	12ga.	2 1/4"



*Available as Custom Order, two weeks lead time, minimum quantity required

Sign Post

Cast Iron Sign Post

The black cast iron base is available in two sizes. The steel round post and wheel are black powder coated. The wheel attaches to base to make these portable and easy to transport

ITEM NO.	DESCRIPTION
HDUCPGP4	14" Mounting Base W/Bolt
HDUCPGP5	18" Mounting Base W/Bolt
HDUCP-POST	48" Round Post Steel
HDUCP-WHEEL	Wheel Attachment



Flat Iron

20' length.

ITEM NO.	GAUGE	SIZE
HDFI118	1/8"	1"
HDFI11218	1/8"	1½"
HDFI136	3/16"	1"
HDFI214	1/4"	2"

Steel Angle

20' length.

ITEM NO.	GAUGE	SIZE
HDAI2X2X14	1/4"	2" x 2"
HDAI150X150X18	1/8"	1½" x 1½"
HDAI1X1X18	1/8"	1" x 1"
HDAI2X2X18	1/8"	2" x 2"

Angle Iron Perforated

ITEM NO.	SIZE
HDAI1P	1-1/4" x 14'3"

Flo-Form Galvanized Angle

20' length.

ITEM NO.	GAUGE	SIZE
HDAIG150X150X18	1/8"	1½" x 1½"
HDAIG2X2X18	1/8"	2" x 2"
HDAIG150X150X36	3/16"	1½" x 1½"
HDAIG250X250X36	3/16"	2½" x 2½"
HDAIG2X2X316	3/16"	2" x 2"
HDAIG3X3X36	3/16"	3" x 3"
HDAIG250X250X14	1/4"	2½" x 2½"
HDAIG3X3X14	1/4"	3" x 3"
HDAIG3X3X50X14	1/4"	3" x 3½"
HDAIG4X4X14	1/4"	4" x 4"

When purchasing materials for a specific project, many sign shop owners spend a great deal of time shopping for the lowest priced supplies in order to make the highest profit from the job. Some

spend hours calling every supplier they can find, and finding the lowest

price may have saved them a few dollars, sometimes even pennies. Remember when shopping for materials that it is not always

important to find the lowest

price, but the best quality product you can buy for

your money. Using higher quality materials will better

ensure repeat business after the client's job is complete. Saving a

few dollars here and there may seem to add up to a larger amount, but the

time you spend calling 5 or more different suppliers is even more valuable than the

50 cents you may have saved. Find one or two main suppliers that offer a wide range

of quality products. You will establish a more comfortable, secure working relationship

with your supplier and they will genuinely appreciate your business.

One-stop shopping will save you time, headaches, and money.

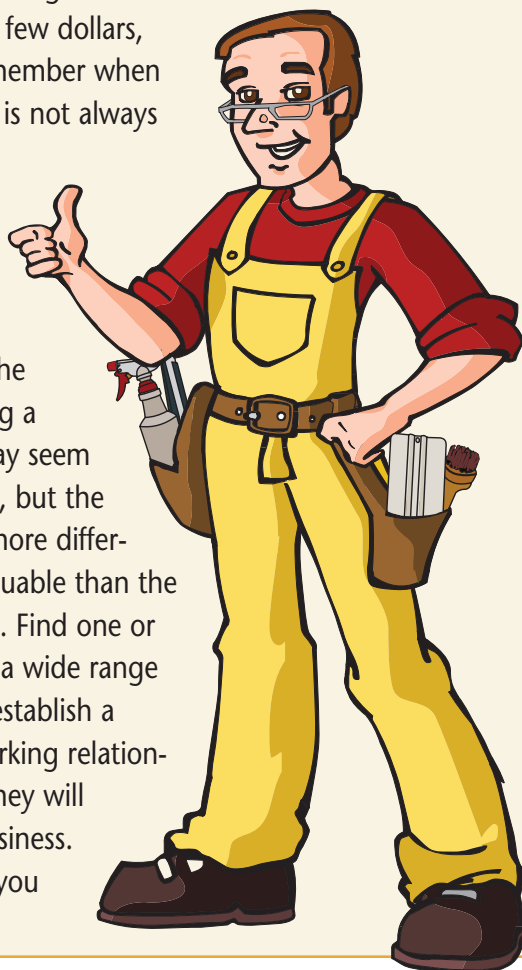



www.sfsupplies.com

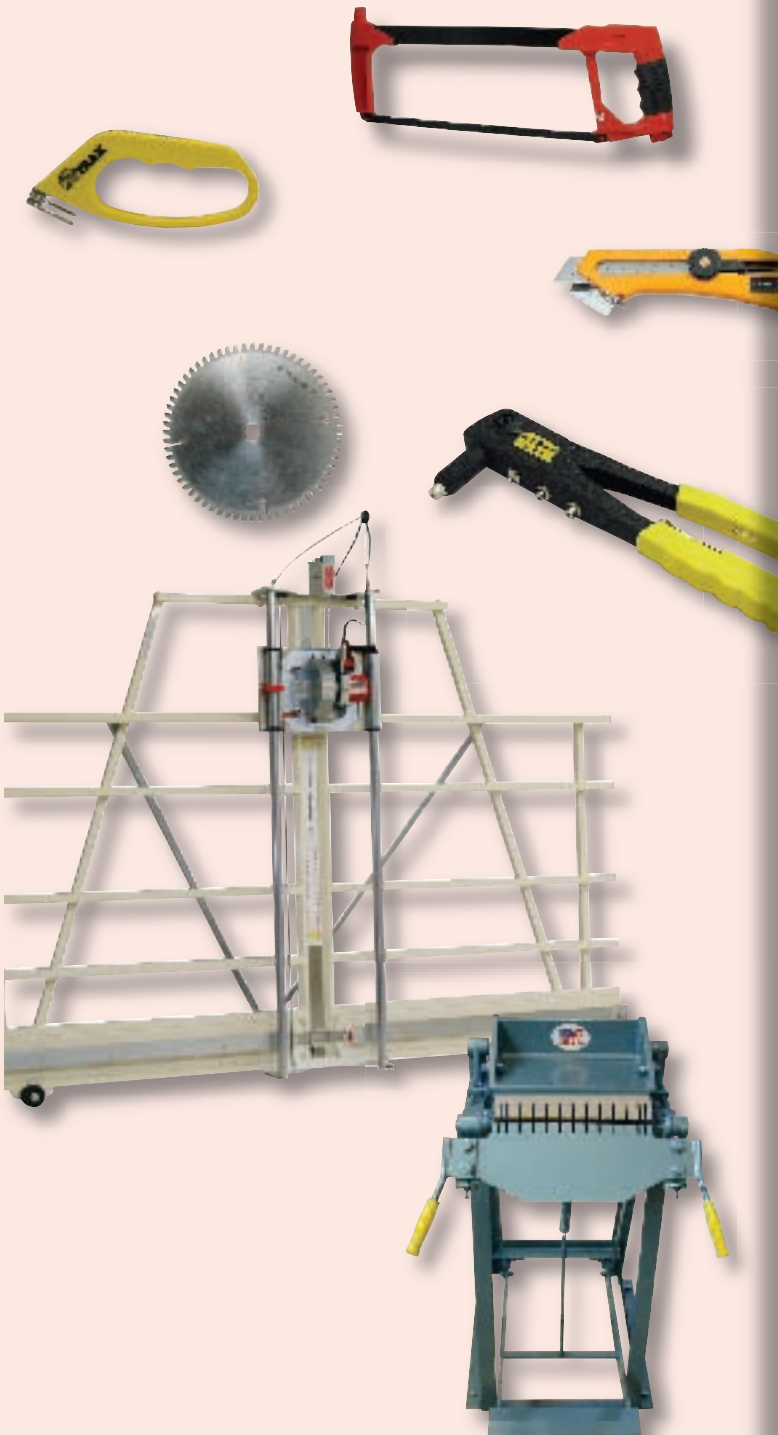

INDEX

DIGITAL MEDIA	5
SIGN VINYL	45
VINYL AND WRAP SUPPLIES	59
WIDE FORMAT EQUIPMENT	73
VINYL CUTTERS	87
ENGRAVERS	95
SOFTWARE	97
SUBSTRATES	105
BANNER	127
SIGN DISPLAY	139
TAPES & ADHESIVES	145
PAINT	153
NEON SUPPLIES & EQUIPMENT	167
TRANSFORMERS	207
LED SYSTEMS	229
LIGHTING & ELECTRIC	243
SIGN EXTRUSION	267
LETTER & ACCESSORIES	277
MOUNTING HARDWARE	281
EQUIPMENT & SHOP TOOLS	293

Metal Bending.....	294
Saws, Benders	295
Hand Tools.....	296-298
Cutters	299

Metal Bending

Channel Master 27"

The perfect compact channel letter finger brake!



ITEM NO. HDCHMA-27

48" Portable Mini Brake



Makes bends to 135 degrees in galvanized sheet steel up to 22 gauge (0.86 mm). A beefed-up 1/4" (6.4 mm) plate steel apron and 4' (1.22 m) metal width capacity makes the Mini Brake ideal for fabricating plenums or large transitions at the job site. Accommodates sheet metal up to 4 feet wide. Optional Leg Kit that are easily installed in the field available.

ITEM NO.	DESCRIPTION
HDMPMB48	48" Mini Brake
HDMPMBL	Leg Kit

Ruoff Notcher Style #1 "V"

The Ruoff Notcher is a punch press with an adjustable automatic feed. It is precision designed for punching various shapes along the edge of the sheet material. Sheet steel, galvanized iron, aluminum, plastics, cardboard, or any sheet material that can be handled by the Ruoff Notcher.



ITEM NO. HDRNNMFW1

48" Box & Pan Channel Brake



Extra-wide capacity for many types of fabrication projects. Hardened steel "fingers" can be removed or repositioned for custom metalwork. Includes 16 fingers: five 2" dies, six 3" dies and five 4" dies.

- Bends steel as thick as 16 gauge
- Makes bends from 1°-135°
- Mounts to workbench
- Maximum jaw opening: 1-1/8"
- Overall dimensions: 13-3/4" L x 59"W x 21-1/8"H
- Shipping weight: 374 lbs.

ITEM NO. HDCB48

Roper Whitney #1016 Bending Brake



- Length of bed: 121"
- Capacity on mild steel, 1" flange,
 - With bending bar and angle in place: 16 ga.
 - With bending angle removed: 20 ga.
 - With bending bar and angle removed: 23 ga.
- Minimum reverse bend (bar and angle removed): 1/4"
- Maximum lift of beam: 2-1/4"
- Front to rear adjustment of beam: 1-3/8"
- Shipping Weight: 2660 lbs.

ITEM NO. RW1016

Quick Return Channel Letter Brake

Constructed of strong and durable steel, The "Quick Return" is a fast manual brake. No feeding long returns in and out of the brake to make reverse bends. Simply flip your material over and make your bend with ease. This machine easily bends 150-degree angles, as for the inside of the letter A.

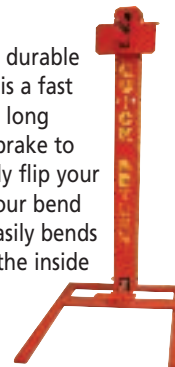

ITEM NO. HDCBQR

Roper Whitney Letter Forming Brake No. 99

This unique small bending brake, with its slotted jaws and apron, is especially designed for bending sheet metal strips which have one or more bent-up edges or seams already formed; such as forming the "drum return" on metal sign letters. It may also be used for straight bending of sheet metal up to 12" wide.

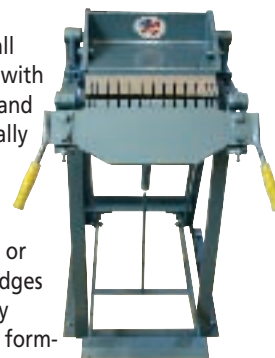

- Capacity Mild Steel: 20 ga.
- Slot Openings: 3/4"
- Max. Opening Between Jaws: 1-1/2"
- Floor Space: 24" x 29"
- Overall Height: 39"

ITEM NO. RW99

Hang Four Fabricator

Hang Four Fabricator allows you to fabricate a wide variety of wall anchors, braces, hangers and more...on the job. It punches, bends, twists and cuts to your specifications with no more costly delays.



ITEM NO. RW4-1MT

Aluminum

No. 50 Angle Iron Notcher

Designed for notching or coping angle iron. No. 50 is portable and can be used in the shop or on the job site. Standard unit has 90° notching blade and die. Coping and special degree notching blades and dies are available. Dimensions (WxLxH): 9-1/2" x 13" x 12"



ITEM NO.	MAX CAPACITY
HD50	2" x 2" x 1/4"

No. 51 Angle Iron Bender

A companion tool to the no. 50 Angle Iron Notcher. It will bend all sizes of angle iron within the rated capacity as well as flat bars. It includes a 32" operating bar handle. Dimensions (WxLxH): 10" x 15" x 5"

ITEM NO.	MAX CAPACITY
HD51	2" x 2" x 1/4"

Aluminum Scroll Bending Machine

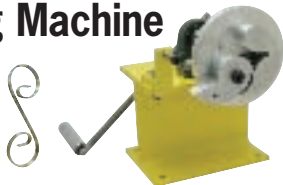

ITEM NO.
ASCPIN-BENDER

Panel Saws

Panel Saw H Series



- 3/4 Hp, 15 amp industrial duty saw motor.
- Zinc plated 1 3/4" steel guide tubes.
- 4 Nylatron roller bearing systems.
- Adjustable vertical and horizontal rulers.
- Thin material pressure guard.
- Spring loaded counter balance system.
- Injection-molded plastic material rollers.
- Quick change from vertical to horizontal cutting.
- 1 year parts warranty.
- Lifetime frame warranty.

ITEM NO.	DESCRIPTION	MAX. CUT VERT.
HDPH5	Panel Saw H-5	64"
HDPH6	Panel Saw H-6	74"

Hold Down Bar

Keeps thin and flexible materials firmly against the machine frame for safe and accurate cutting.

ITEM NO.	DESCRIPTION
HDPHDBH5	For H-5 Panel Saw
HDPHDBH6	For H-6 Panel Saw

The H Series is available with many options. Please consult with your sales rep.

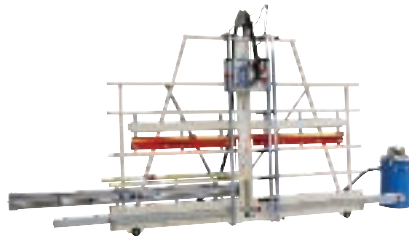

We sell all replacement parts for all Safety Speed Cut panel saws.

Tube Benders

Motorized Tube Bender

- Bench mounted or portable with casters
- Can be positioned vertically or horizontally
- Rollers are close tolerance, solid steel and adjustable



Model# AWSSMITB

- Bends 1/2", 3/4" & 1" square tubing
- Bends up to 1-1/4" round tubing

Model# AWSSMITB2

- Bends 1/2", 3/4", 1" & 2" square tubing
- Bends 1"x2" rectangular tubing in both directions
- Bends 3/4", 1", 1-1/4", 1-1/2" & 2" round tubing

ITEM NO.	DESCRIPTION
AWSSMITB	1" Square
AWSSMITB2	2" Square

Manual Tube Bender

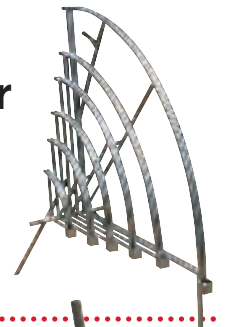

ITEM NO. AWMTB

Lockseam Tube Bender

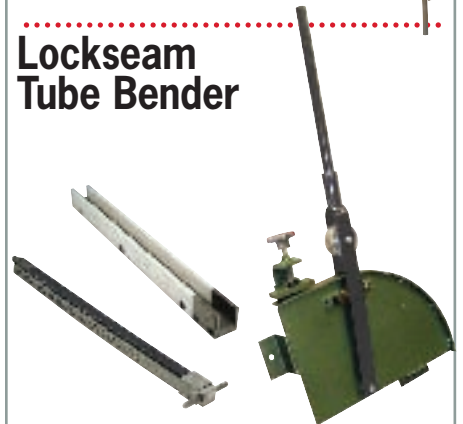

ITEM NO.	DESCRIPTION
ATHB	Lockseam Tube Bender
ATHBFB	"U" Filler Block
ATHB4AINsert	Insert 18"

Hand Tools

Magnetic Hex Chuck Driver



ITEM NO.	DESCRIPTION
HDHCD14178	1/4" x 1 1/8"
HDHCD14212	1/4" x 2 1/2"
HDHCD146	1/4" x 6"
HDHCD516178	5/16" x 1 1/8"
HDHCD516212	5/16" x 2 1/2"
HDHCD38178	3/8" x 1 1/8"
HDHCD38212	3/8" x 2 1/2"
HDHCD716212	7/16" x 2 1/2"

Magnetic Bit Holder



ITEM NO.	DESCRIPTION
HDMBH14	

Head Bits



Philips Head



ITEM NO.	DESCRIPTION
HDBPHL	#2 Long
HDBPH	#2

Flat Head

ITEM NO.	DESCRIPTION
HDBFHL10	#2 Long (Slot Size 10)
HDBFHL12	#2 Long (Slot Size 12)
HDBFHL8	#2 Long (Slot Size 8)

Socket Punch



ITEM NO.	DESCRIPTION
HDEGP	Eagle Socket Punch
HDDP	"D" Punch
HDDPD	"D" Punch Die Only

Round Punch

ITEM NO.	SIZE	ITEM NO.	SIZE
HDP12	1/2"	HDP156	1 5/16"
HDP916	9/16"	HDP138	1 3/8"
HDP34	3/4"	HDP158	1 5/8"
HDP78	7/8"	HDP134	1 3/4"
HDP1	1"	HDP178	1 7/8"
HDP118	1 1/8"	HDP2	2"
HDP114	1 1/4"	HDP218	2 1/8"
HDP176	1 1/16"	HDP214	2 1/4"

Drill Bit



ITEM NO.	SIZE	ITEM NO.	SIZE
HDB16	1/16"	HDB932	9/32"
HDB564	5/64"	HDB1964	19/64"
HDB332	3/32"	HDB516	5/16"
HDB764	7/64"	HDB2164	21/64"
HDB18	1/8"	HDB1132	11/32"
HDB964	9/64"	HDB2364	23/64"
HDB532	5/32"	HDB38	3/8"
HDB1164	11/64"	HDB2564	25/64"
HDB316	3/16"	HDB1332	13/32"
HDB1364	13/64"	HDB2764	27/64"
HDB732	7/32"	HDB716	7/16"
HDB1564	15/64"	HDB1532	15/32"
HDB14	1/4"	HDB3164	31/64"
HDB1764	17/64"	HDB12	1/2"

Double End Drill Bit



ITEM NO.	SIZE
HDB18DE	#1805-1/8"

Masonry Bit



ITEM NO.	SIZE
HDMB14	CM6-1/4"
HDMB316	CM6-3/16"
HDMB18	CM8-1/8"
HDMB58	CM86-5/8"

Hole in One - Hole Saw



One piece arbor and hole saw combinations eliminates the need for separate arbor attachments. 4/6 variable pitch teeth milled into high speed steel edge and micro-welded to body.

ITEM NO.	SIZE
HDMH14	7/8"
HDMH15	15/16"
HDMH22	1-3/8"
HDMH21	1-5/16"
HDMH24	1-1/2"
HDMH28	1-3/4"

Adjustable Chrome Hacksaw



ITEM NO.	DESCRIPTION
HDHS565	Hacksaw
HDBLHSB	Hacksaw Blade

Heavy Duty Hacksaw

12" aluminum heavy duty hacksaw frame with blade - Red Frame.



ITEM NO.	DESCRIPTION
HDHSHD	Heavy Duty Hacksaw
HDBLHSB	Hacksaw Blade

Circular Saw Blade



ITEM NO.	SIZE
HDBLCSB10	10" 100 Teeth Triple Chip
HDBLCSB8	8" 64 Teeth Triple Chip

Chop Saw Blade



ITEM NO.	SIZE
HDBLCSB12	12" x 3/32" x 1" #A1-1240
HDBLCSB14	14" x 3/32" x 1" #A1-1440

Grinding Wheel



ITEM NO.	SIZE
HDBLGW4	4" x 1/4" x 5/8" #A7-4095
HDBLGW412	4 1/2" x 1/4" x 7/8" #A7-4597

Cut Off Wheel



ITEM NO.	SIZE
HDBLCOW412	4 1/2" x 1/8" x 7/8"
HDBLCOW5	5" x 1/8" x 7/8"

Hand Tools

Snips

Aluminum Handled Snips



Sleek styling, easy blade replacement and larger handles make the



Andy™ Snip more versatile. A sleek head design improves maneuverability. Ideal for making cuts in tight material, shapes such as J-Channel. A full 3" (76.2 mm) cutting length makes straight shearing with the Malco Andy™ Snip fast and easy.

Optional Snip Holster available

Andy™ 12" #M12N, 14" #M14N

The Gray Pattern Snip's ground blade edge is suitable for mild curve cuts and ideal for fast, straight shearing or cutting multiple layers of sheet metal.

Andy™ 12" #MC12N, 14" MC14N

The Charcoal Combination Snip's beveled blade edge is versatile for straight shearing and left or right circular cuts down to 6-inch diameter.

ITEM NO.	DESCRIPTION
HDM12	12" M12N
HDMC12	12" MC12N
HDM14	14" M14N
HDMC14	14" MC14N
HDMTTP201	Leather Snip Holster

Aviation Snips

Aviation snips are designed for professional as well as home use. Cuts aluminum, sheet metal, shingles, leather, floor coverings, paper, cardboard, and plastic. Available in three models – straight cut, right cut, and left cut. Colorcoded for easy identification.



ITEM NO.	DESCRIPTION
HDMASC	Straight (Yellow)
HDMASL	Left (Red)
HDMASR	Right (Green)

Seamers

Hand Seamers with Forged Steel Jaws



Jaws are drop forged, high impact steel. Hardened steel handles resist abuse.

S2 3" Hand Seamer



S3 3" Offset Hand Seamer



Works overhead or in confined areas.

S6 6" Hand Seamer



Wide 6" jaws produce uniform, accurate bends in sheet steel and non-ferrous metals with greater control and efficiency.

ITEM NO.	DESCRIPTION
HDMS2	3" Hand Seamer
HDMS3	3" Offset Hand Seamer
HDMS6	6" Hand Seamer

Turbo Shear Heavy Duty



The rugged TurboShear HD cuts straight and to the left and makes fast cuts in material thickness up to 18-gauge galvanized steel. Cutting applications include both ferrous and non-ferrous sheet metals, metal roofing/building panels, vinyl, steel mesh, ductwork, etc..



- Inserts into chuck of 14.4 volt or larger A/C or cordless drill.
- Navigates tight patterns and square cuts.
- Cuts a variety of building materials with the ability to reposition upside down for greater maneuverability.

ITEM NO. HDMTSHD

Notchers

N1 Hand Notcher



Fast and easy cutting. Notcher makes a clean 30° "V" shaped cut in sheet metal. 13/16" (20.6 mm) maximum throat depth. Upper cutting jaw is drop forged high impact alloy steel.



ITEM NO. HDMN1

Spring Replacement

ITEM NO. HDMN1RS

Roper Whitney Hand Notchers

HD141



ITEM NO.	DESCRIPTION
HD141	No. 141 Portable Notcher (30°)
HD541	No. 541 Series 90° Hand Notcher w/90° Blade Set
HD542	No. 542 Series 45° Hand Notcher w/45° Blade & Die

GENERAL Metal/Wire Gauge Tester (No.20)

used for gaging non-ferrous wire and metals such as copper, brass and aluminum. Decimal equivalents of each size are stamped on reverse side. It is 3-3/4" in diameter and 3/32" thick.



ITEM NO. HDGTM

GENERAL SCREW GAUGE No.714

For identifying screws, bolts, rivets and common cotter pin sizes up to 5/16".

- Cross-reference drill bit and tap guide
- Threaded holes for measuring threads per inch.
- Screw sizes indicated in numbers and fractions of an inch.
- 3" rule for measuring screw lengths.



ITEM NO. HDGTS

Hand Tools

Wire Strippers

Wire Stripper
Stripmaster #45-092
#10 to #22 AWG



- Knife-type blades
- Cleanly strips wire up to 7/8 in. (22mm)
- One-third less hand pressure for each strip
- Eliminates nicking, cutting, and fraying of wire
- Wire Gripper holds wire centered in hole

ITEM NO. EWSM-092

Automatic Wire Stripper
#12 to #20 AWG



ITEM NO. HDWS

Spring Clamp

Just a simple squeeze and release is all it takes to keep fabric held securely in place. These spring clamps are unbeatable for securing fabric to awning frame, plus hundreds of other shop chores that require an "extra hand".



ITEM NO.	DESCRIPTION
AWSC1	Spring Clamp 1"
AWSC2	Spring Clamp 2"
AWSC3	Spring Clamp 3"

Heat Gun Tool

1220 HS



Dual heat selection – 750 degrees F and 1000 degrees F.

Use for fast, easy, one-step paint removal and dozens of other uses. Includes a hanging hook.

Power: 1200 Watts / 4100 BTUs.

ITEM NO. HDHG1220HS

Industrial 750

Variable heat selection, 500-750 degrees F.

Professional quality heat gun features maximum BTU heat output, high air flow, fast heat transfer, and heavy duty all-metal construction.



Power: 1680 Watts / 5700 BTUs.

ITEM NO. HDHG750

HT1100



Heat Gun Kit

Two temperature settings 750° F. and 1000° F.

Contains accessories that are necessary to heat and strip paint from a surface.



Included: Concentrator nozzle, spreader nozzle, glass protector nozzle, a handle with five multi-shaped scraper blades and a rugged storage case.

Power: 1200 Watts / 4100 BTUs.

ITEM NO. HDHGHT1100

HT3500



Digital Heat Gun

Touch-pads activate 12 distinct temperature settings from 250° to 1350° F. enabling the user to match the correct temperature to the application. Two fan speeds for optimum air flow control. Cool-down and automatic shut-off setting.



Power: 1500 Watts / 5100 BTUs.

ITEM NO. HDHGHT3500

Rivet Guns

VHR-1 Hand Riveter



Durable wrinkle painted metal handle.

4 nosepieces 3/32", 1/8", 5/32" & 3/16".

ITEM NO. HDRGVHR-1

HP-2/39000 Rivet Gun

Known and trusted for durability, quality and performance, the HP-2 sets up to 3/16" steel rivets and comes with four mounted nosepieces (3/32", 1/8", 5/32", and 3/16") and a service wrench.



ITEM NO. HDRG2001

Hand Riveter
2 in 1



One hand operation with normal squeezing action provides enough pulling power to set all popular size rivets. 2-in-1 adjustment features a single long stroke for most hand riveting applications and a short "ratchet action" power stroke for setting larger diameter rivets.



- 3 Nosepieces (1/8", 5/32", 3/16")
- Long Stroke
- Short "Ratchet Action" Power Stroke

ITEM NO. HDRG21

V-3 Pneumatic Rivet Gun



ITEM NO. HDRGPV3

Inlet Fitting

ITEM NO. HDRGPV3-42



Cutters

PC-L Heavy-Duty Plastic/Laminate Cutter



Heavy-duty plastic/laminate cutter designed as a scoring tool for sheet plastics and laminates, allowing for the precise breaking of plastics. Features a ratchet-wheel for secure blade extension and retraction, and unlimited blade positioning.

ITEM NO.	DESCRIPTION
LYOPCL	Cutter
LYPB800	Replacement Blades, 3 pack

Coro Claw Coroplast Cutter

Cut along the flutes or score along the flutes to make a stand or cover. Every shop needs at least one!



- Score cut with the outer most talon.
- Cut through using the second talon.

ITEM NO. CPCC

10mm CoroPlast Cutter

Includes a replacement blade.



ITEM NO. CPCC10

Heavy-Duty Cutter

CL Heavy-Duty Packaging Cutter



In addition to the ratchet wheel blade lock and stainless steel blade channel, this cutter provides a 90-degree cutting base, an adjustable depth gauge and a built-in staple remover.

ITEM NO. LYOCL

L-2 Heavy-Duty Cutter



Sure-grip heavy-duty utility cutter features a ratchet wheel blade lock, heavy gauge stainless steel blade channel, highest grade carbon tool steel blade and anti-slip rubber grip insert.

ITEM NO. LYOL2

LB Heavy-Duty, Snap-Off Replacement Blades

Heavy-duty, snap-off replacement blades. Each blade is produced using OLFA's precise multi-step production process for amazing sharpness and superior edge retention. 8 cutting edges per blade strip.

ITEM NO.	DESCRIPTION
LYOLB10B	10 pack
LYOLB50B	50 pack

Brown Kraft Paper #70 lb.



ITEM NO.	SIZE
LYPBC24	24"
LYPBC36	36"
LYPBC48	48"
LYPBC60	60"

Utility Knife

Heavy duty metal body.



ITEM NO.	DESCRIPTION
HDMUK	Utility Knife
HDMUSB5	Replacement Blades, 5 pack
HDMUSB50	Replacement Blades, 50 pack

Metal Safety Glass Scraper

Comes with 5 single edge blades for removing paint, stickers on windows and doors.

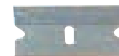

ITEM NO.	DESCRIPTION
HDGS	Glass Scraper
LYRBB	Razor Blades #9, 100 pack

Plastic Razor Blades with Holder

Double-Edged plastic blade that is strong in design and fits any standard razor holder. it is designed to aid in the removal of pressure-sensitive materials on surfaces that are easily scratched. (metal, paint, plastics, glass, etc.) Comes with a blade holder. 25 plastic blades per pack.



ITEM NO. LYPRB

Clear Tape

Roll seal tape, clear.



ITEM NO.	DESCRIPTION
LYSTCLR110	2" x 110 yds.

Duct Tape

Roll gray duct tape,



ITEM NO.	DESCRIPTION
LYDT	2" x 60 yds.

- 0-40 Torr Capsule Fill Gauge 177
5 Point Crossfire 184
90° Connector 203
- A**
- A Frame 141
Acetone 161
Acrylic Adhesive Lord 149
Acrylic Adhesive Weld On 151
Acrylic Blocks 278
Acrylic Clear Overcoat 159
Adhesive Remover Spray 152
Alcohol 161
Alumalite 118
Aluminum Angle 268
Aluminum Center Straight 269
Aluminum Center T 269
Aluminum Corner 269
Aluminum Divider Bar 268
Aluminum Extension Post 205
Aluminum Handle Needle Point 64
Aluminum Louvers 270
Aluminum Molding 90° 268
Aluminum Piano Hinge 270
Aluminum Rivets 284
Aluminum Scroll Bending Machine 295
Aluminum Sheeting 106-109
Aluminum Sign Molding 269
Aluminum Snips 297
Aluminum Studs 278
Aluminum Tubing 269
Aluminum Wall Bracket 269
Analog Capsule Pressure Gauge 171
Analog Vacuum Gauge 171
Angle Iron Bender 295
Angle Iron Notcher 295
Angle Steel 292
Application Tape 60-61
Application Tape Transfer System 63
Architectural Aluminum Angle 268
Architectural Extrusions 276
Artist Brush 166
Aurora Clip Art 101-103
Avery Sign Vinyl 46-53
Aviation Snip 297
- B**
- Ball for Pole Bracket 129
Ballast 245-251
Ballast Lite O Line 253
Ballast Wire 260
Bandana Banner 128
Banner Grand Opening 129
Banner Hem Tape 135
Banner Klip 136
Banner Pole Bracket 129
Banner Rolls 128
Banner Stands 137-138
Banner Ups 134
Banner Washer 291
Bending Brake 294
Bestine Solvent & Thinner 161
Bi Pin Lampholder 255
Blanks, Coroplast 123
Blockout Brush 205
Blockout Paint 205
Blockout Thinner 205
Blow Hose 185
Blowers 186
Blue Painters Tape 70
Bobbins 135
Bombarders 173, 180
Bombarding Mica 188
Bombarding Milliamp Meter 180
Bombarding Temperature Gauge 180
Bond-240 PB 124
Brake Away Handle 67
Bronze Screen 188
Brown Kraft Paper 70
Brush Oil 160
Brushes Lettering 166
Bulbs Led Color Changing 255
Bulletin Enamel
Bushing Federal 218
Bushing Heyco 218
- C**
- Cabbie Taxi Top 144
Cable Clamps 260
Cable Support 201
Cable Wire Sloan 235
Candelabra Base Bulbs 255
Cannon Crossfire 184
Capping Plastic 279
Car Window Clip 142
Cast Iron Sign Post 292
Ceramic Socket 256
Chain 289
Chalkboard Film 58
Channel LED 5 232
Channel Letter Aluminum Coil 109
Channel Letter Trim 278
Channel Master 294
Charcoal Black 70
Chasers 262
Chasing Bulbs 255
China Marker 70, 188
Chizler Vinyl Removal Tool 66
Chokes 180
Chop Saw Blade 296
Circular Saw Blade 296
Clear Tape 299
Clear Vinyl Covering GTO 200
Clear Vue Tube Support 205
Clip Art 100-103
Clock, Open Face 266
Cold Cathode Housing 217
Cold Cathode Transformer 217
Cold Cathode Transformer Box 218
Colonial Swing Post Frame 140
Color Checker 187
Color Core 120
Color Line LED 234
Commercial Extrusion 276
Complete A Frame 141
Concrete Screws 283
Conduit Connector 260
Conduit EMT 260
Conduit Non Metallic 260
Conduit Plug Assembly 203
Contact Cement 152
Cooley SM-42 125
Copper Wire 205
Corks 187
Coro Stakes 140
Coroplast 123
Coroplast Blanks 123
Covering GTO 200
Crane Style Frame 140
Crossfire Hose 185
Crystal Green Degreaser 68
Custom Made Banner 128
Cut Off Wheel 296
Cutters/Trimmers 85-86
- D**
- D Rings 136
Day Glo Paper 126
Decorative Vinyl 56-57
Denatured Alcohol 161
Diffusion Pump 171, 178
Digi Bond (DiBond) 119
Digi Mask Clear 69
Digital Clamp-On Multimeter 217
Digital Map Measure 187
Digital Media Solvent 6-22
Banner 20-22
Calendered Vinyl 7-11
Canvas 19
Etch Vinyl 15
Fabric 19
Film 18
Floor Vinyl 11
Metalized Vinyl 16
Perforated Vinyl 12
Photo Paper 17
Reflective Vinyl 15
Semi-Rigid Vinyl 12
Static Cling 13
Street Graphics Vinyl 16
Transit Vinyl 12
Translucent Vinyl 14
Wall Covering Vinyl 12
Wrap Vinyl Cast 6
Digital Media Water-Based 23-36
Banner 34-35
Canvas 36
Coated Paper 27
Fabric 36
Film 29-31
Fine Art Paper 28
Photo Realistic Paper 25
Photobase Paper 23-24
Self Adhesive Paper 26
Vinyl 32-33
Digital Pirani Vacuum Gauge 171
Digital Temperature Gauge 173
Digital Vacuum Gauge 178
Dimmers 201
Dividers 279
Divider Plastic 279
Divider Sign Comp 271
D-lite 118
Dome Caps 282
Double Sided Film Tape 135
Double Sided Foam Tape 146
Dow Corning high Vacuum Grease 172
Dowl Pins 118
Drill Bit 296
Drive Cap U Channel Post 291
Dual Lock Reclosable Fastener 147
Duct Tape 299
Dura Bond 119
Dust Mask 164
- E**
- Eagle Socket 255
Econo Comp 271
Econolite 118
Edge Caps 117
Edge Lit LED Extrusions 273
Eggcrates 252
EGL Electrode 193-194
EGL Glass 189-192
Electric T11 Conduit Box 256
Electric Tape 260
Electric Tube Cutter 188
Electric Wire 260
Electrode Buttons Brass 197
Electrode Caps Brass 197
Electrode Holder 187
Electrode Housing Boots 197
Electrode Housing Sleeve Wide 198
Electrode Housing Wide 198
Electrode Insulator 198
Electrode Saver Brass 197
Electronic Milliamp Meter 217
Electronic Sign Ballast 249-250
Elmers Glue 152
EMT Conduit 260
End Caps 198-199
Engravers 96
Epoxy Adhesives 149
Etchmark Sign Vinyl 49
Extreme Adhesive 147
Extruded Aluminum Angle 268
Eye Bolts 287
EZ Grip Squeezegee Handle 63
EZ Gripper 63
EZ Read Pressure Gauge 171
EZ Up Mounting Bracket 218
- F**
- F Style Frame 141
Fast Set PB 124
Federal Bushing 218
Fender Washers 283
Filters 186
Finales 124
Fixure Light-O-Line 253
Fixtures, Awning 252
Fixtures, Gooseneck Designer 257-258
Fixtures, Slimline 255
Flashers 261-262
Flat Iron 292
Flat Washer 283
Flattening Paste 155
Flex Face Material 125
Flex Frame 141
Flexi 10 Software 98
FlexiBrite LED 234
Flo Form Galvanized Angle 292
Floor Stand Frame 141
Fluorescent Lamps 254
Fluorescent Corrugated Sheets 123
Fluorescent Spray 165
Flushing Oil 179
Foam Board 121-122
Foam Rollers 163
Foam Rubber 279
Foam Tape Double Sided 146

- Portable Sign Stand.....143
 Poster Paint 1 Shot.....155
 Pounce Unit, Electro.....188
 Pounce Wheel.....70
 Power Grip Magic Pad.....64
 Power Grip Multi-Pin Air Release.....64
 PowerPunch Hole Cutter Tool.....134
 Power Supply Neon Pro.....241
 Power Supply Permlight.....240
 Power Supply Sloan.....236
 Power Tape.....134
 Precision Board.....124
 Precision Vacuum Gauges.....178
 Price Tag Molding Plastic.....279
 Pro Designer.....101
 Pro V Tube Support.....205
 Promo Calendered Sign Vinyl.....46
 Pronto Track Plastic.....279
 Propane Cylinders.....69
 Protection Strip for Plotters.....89,91
 Protect A Lamp.....255
 PVC Sheets.....116
- Q**
- Quick Dry Enamel.....155
 Quick Link Connectors.....136,288
 Quick Return Channel Brake.....294
 Quick Support.....205
 Quik Connect.....203
- R**
- R Style Frame.....141
 Raceway Socket.....270
 Rags.....69
 Rapid Prep.....65
 Rawhide Mallet.....130
 Razer Blades.....66
 Realicade.....142
 Receptacle Tester.....217
 Rechargeable Tube Tester.....187
 Reducer Paint.....160
 Reflective Beads.....
 Reflective Sign Vinyl.....50
 Resin Bond.....152,279
 Resin Clear Coat PB.....124
 Retractable Banner Stands.....137-138
 Retro Frame System.....276
 Reverse Molding.....270
 Ribbon Burner.....183
 Ring Terminals.....201
 Rivet Brush.....64
 Rivet Gun.....298
 Rivets.....284-286
 Roland Inks.....80
 Roland Plotter & Parts.....88-89
 Roland Printers & Accessories.....74-79
 Run Glo Fluorescent.....155
 Rope.....135
 Rotary Cutter.....66
 Rotators.....265
 Rubber Cement.....152
 Rulers.....71
- S**
- S Hooks.....288
 Safety Ruler.....71
 Sandwich Magnet.....279
 Screw Eyes.....288
 Screw Gauge.....297
 Screws.....282
 Scroll Bracket Deluxe.....144
 Sealing Bushing (Passthru).....202
 Sealing Ring (Passthru).....202
 Self Drilling Screws.....282
 Self Piercing Screws.....282
 Sheet Metal Screws.....282
 Short Stops.....198-199
 Sidewalk Sign.....144
 Siding Light Box.....270
 Sign Ballast.....245-251
 Sign Board.....117
 Sign Bulb.....255
 Sign Comp Extrusions.....271-276
 Sign Gold Vinyl.....54-55
 Sign Grabber.....291
 Sign Hangers.....120, 290
 Sign Hook.....290
 Sign Link.....291
 Sign Mounting Bracket.....290
 Sign Ply.....117
 Sign Post Cast Iron.....292
 Sign Restoring Clear.....159
 Sign Stakes.....140
 Sign Vinyl.....46-55
 Signa Sign Ballast.....250-251
 Signboard Adhesive.....147
 Signcade.....143
 Signlab Software.....99
 Silicone.....152
 Silicone GTO.....200
 Silicone Gun.....152
 Silver Thinned Tie Wire.....205
 SimpoSign.....143
 Single Jack Chain.....289
 Sleeving GTO.....200
 Slimline Ballast.....255
 Slimline Fixture & Lamp.....255
 Slip Stick Bushing.....196
 Sloan LED.....231-236
 SM-42 Cooley.....125
 Smooth Corrugated Sheet.....123
 Snap Blade Knife.....67
 Snap Hooks.....136
 Snap Off Replacement Blade.....67
 Snips.....297
 Socket Candelabra.....255
 Socket Eagle.....255
 Socket Lite-O-Line.....253
 Socket Punch.....296
 Socket Raceway.....270,272
 Spacers (Quik Connect).....203
 Spacers Plastic.....278
 Spark Coil Tester.....187
 Speed Dry Enamel.....155
 Speed Dry UV Acrylic Clear.....159
 Spellers.....263
 Spider Stake.....142
 Spray Adhesive.....152
 Spray Bottle.....65
 Spray Mount Adhesive.....147
 Spring Assembly (PK Housing).....197
 Spring Clamps.....298
 Square Fit.....291
 Square Rod Plastic.....278
- Squarecade.....143
 Squeegee.....63
 Stabilo Pencil.....70
 Stazon Paint.....205
 Steam Distilled Turpentine.....161
 Steel Angle.....292
 Steel End Tabs.....269
 Steel Frames.....140-141
 Steel Rivets.....285
 Straight Connector.....203
 Strain Relief.....203
 Strain Relief for PK.....195
 Streamers Metallic.....129
 Striping Magnetic.....126
 Structural Adhesives Weld On.....151
 Suction Cups.....136,288
 Supercast Sign Vinyl.....48-49
 Switch Toggle.....260
 Swivel EGL.....185
- T**
- T Cade.....142
 T Splitter.....184
 T Track Plastic.....279
 T11 Electric Conduit Box.....256
 T-4 Sign Beads.....160
 Tap Bolts.....282
 Tape Double Sided.....146
 Tape Measure.....71
 Tape Primer.....65
 Taracloth Rolls.....128
 Taxi Top Signs.....144
 T-Bar Stake.....140
 Tension Clips System.....276
 Textured Surface Applicator.....64
 ThinLed LED.....233
 Thinners.....161
 Thread.....135
 Tie Wire.....205
 Time Clock.....264
 Toggle Switch.....260
 Tombstone Sockets.....256
 Tool Belt.....69
 Tough Coat.....166
 Transformer Box.....218
 Transformer LedStripe.....236
 Transformer Raceway Sign Comp.....273
 Transformer Selektor.....217
 Transformers.....208-228
 TSF-45 Texture Surface Finish PB.....124
 Tube Bender.....295
 Tube Support Glass.....204
 Tube Tester.....187
 Tubing LED.....234-235
 Turbo Shear.....297
 Turpentine.....161
 Tweezers.....68
 Twist Lock Wire Nuts.....260
 Twister752 Permlight.....238
 TwisterHalo Permlight.....237
 TwisterNano Permlight.....237
 TwisterNitro777 Permlight.....239
 TwisterStar753 Permlight.....238
 Tyvek Banner.....128
- U**
- U Bolts.....289
 U Bracket.....290
 U Channel Post.....291
 U Gauge Fluid.....177
 U Gauge Manometer Complete.....177
 U Lamps.....254
 U Sign Hanger.....117,290
 Ultra Aluminum.....122
 Ultra Board.....122
 Ultra Core.....121
 Ultra Glass Cleaner.....68
 Ultra Mount.....121
 Ultra Plus.....122
 Ultra Violet Color checker.....187
 Urethane Adhesive.....149
 USA Sign Starter Kit.....142
 U-Stake.....140
 Utility Knife.....299
 UV Resistant Clear Spray.....165
- V**
- V Series LED.....232
 Vacuum Gauge Stopcock.....177
 Vacuum Hose.....179
 Vacuum Pump Oil.....179
 Vacuum Pumps.....179
 Value line LED.....233
 Vector Art Clip Art.....100-101
 Vehicle Channel Applicator.....64
 Ventex 12VDC Power Supplies.....228
 Ventex Indoor Transformers.....225
 Ventex Wall Adapter.....228
 VHB Double face Foam Tape.....146
 Vinyl Adhesives Weld On.....151
 Vinyl Application Fluid.....65
 Vinyl Cutter Tool.....67
 Vinyl Cutters.....88-94
 Vinyl Edge Sealer.....65
 Vinyl Racks.....62
 Vinyl Removal Tool.....66
 Vinyl Remover.....65
 Vinyl Roller Applicator.....64
 Vinyl Roller Tray.....62
- W**
- Washers.....283
 Wall Frames Sign comp.....273
 Waterproof Fixture Covers.....252
 Webbing.....135
 Weld On Product Selector.....150
 Welded Chain.....289
 Welding Torch.....69
 White Paper.....70
 Wide Format Equipment.....74-86
 Wil Bond.....161
 Wind Sign.....144
 Wind Spinner.....141
 Window Juice.....65
 Window Paint.....160
 Wire Nuts.....235,260
 Wire Stripper.....298
 Wiring Diagram for Sign Ballast.....248
 Wrap Wash Polish Kit.....68
 Wrapture Wrap Design.....103
- X**
- X-acto Blades.....67
 X-acto Handle Knife.....67
- Z**
- Z Hooks.....290

Please copy and use this form when placing orders via fax



BROOKLYN
110 Emerson Place, Brooklyn, NY 11205
718.399.3333
FARMINGDALE
43 Engineers Lane, Farmingdale, NY 11735
631.420.4400



Date ____ / ____ / ____

PO #

Master Distributors of SIGN and AWNING Materials & Equipment

Company Name _____ Name _____

Address _____ City _____ State _____ Zip _____

Phone () _____ Fax () _____

	QUAN.	ITEM #	DESCRIPTION	PRICE
1				
2				
3				
4				
5				
6				
7				
8				
9				
10				
11				
12				
13				
14				
15				
16				
17				
18				

FAX FREE TO 1-888-399-3375
1% UNCONDITIONAL DISCOUNT OFF ENTIRE ORDER



CREDIT APPLICATION

COMPANY INFORMATION

BUSINESS NAME _____
 DATE ESTABLISHED _____
 ADDRESS _____
 CITY _____ STATE _____ ZIP CODE _____
 PHONE _____ FAX _____

Type of Business

Corporation Partnership Individual Ownership

TAX RESALE NO. _____

Names of owners/officers

NAME _____	NAME _____
TITLE _____	TITLE _____
ADDRESS _____	ADDRESS _____
CITY _____ STATE _____ ZIP CODE _____	CITY _____ STATE _____ ZIP CODE _____

We estimate our monthly credit requirements from S&F Supplies to be \$ _____

BANK REFERENCE

BANK NAME _____
 ADDRESS _____
 CITY _____ STATE _____ ZIP CODE _____
 PHONE _____ FAX _____
 CONTACT NAME _____

Type of Bank Account

Checking Savings Loan Secured
 Unsecured

Account/Loan No. _____

BUSINESS REFERENCE

NAME _____	NAME _____
ADDRESS _____	ADDRESS _____
CITY _____ STATE _____ ZIP CODE _____	CITY _____ STATE _____ ZIP CODE _____
PHONE _____ FAX _____	PHONE _____ FAX _____
CONTACT NAME _____	CONTACT NAME _____

NAME _____	NAME _____
ADDRESS _____	ADDRESS _____
CITY _____ STATE _____ ZIP CODE _____	CITY _____ STATE _____ ZIP CODE _____
PHONE _____ FAX _____	PHONE _____ FAX _____
CONTACT NAME _____	CONTACT NAME _____

CONFIRMATION OF INFORMATION ACCURACY AND PERSONAL GUARANTEE

I, (we) hereby certify that the information in this application is correct. The information included in this application is for use by S&F Supplies, in determining the amount and conditions of credit to be extended. I, (we) understand that S&F Supplies Inc. may also utilize the other sources of credit which is necessary in making this determination. Further I, (we) hereby authorize the bank and trade references listed in this application to release the information necessary for S&F Supplies, in establishing a line of credit. I, (we) individually, personally, jointly, severally guarantee payment on this account. This personal guarantee cannot be changed orally. Applicant(s) will be responsible for reasonable collection and/or legal costs incurred for non payment. Read and accepted by the undersigned subject to terms and conditions.

Authorized Signature _____	Title _____	Date _____
Authorized Signature _____	Title _____	Date _____

Please mail or fax this application to:
 S&F SUPPLIES INC., P.O. BOX 050071, BROOKLYN, N.Y. 11205 • FAX: 718-399-3375

Fraction/Decimal/Millimeter Conversion Chart

FRACTION	DECIMAL	MM	FRACTION	DECIMAL	MM
1/64	.0156	.396	33/64	.5156	13.096
1/32	.0312	.793	17/32	.5313	13.493
3/64	.0469	1.190	35/64	.5469	13.890
1/16	.0625	1.587	9/16	.5625	14.287
5/64	.0781	1.984	37/64	.5781	14.684
3/32	.0938	2.381	19/32	.5938	15.081
7/64	.1094	2.778	39/64	.6094	15.478
1/8	.1250	3.175	5/8	.6250	15.875
9/64	.1406	3.571	41/64	.6406	16.271
5/32	.1562	3.968	21/32	.6563	16.668
11/64	.1719	4.365	43/64	.6719	17.065
3/16	.1875	4.762	11/16	.6875	17.462
13/64	.2031	5.159	45/64	.7031	17.859
7/32	.2188	5.556	23/32	.7188	18.256
15/64	.2344	5.953	47/64	.7344	18.653
1/4	.2500	6.350	3/4	.7500	19.050
17/64	.2656	6.746	49/64	.7656	19.446
9/32	.2813	7.143	25/32	.7813	19.843
19/64	.2969	7.540	51/64	.7969	20.240
5/16	.3125	7.937	13/16	.8125	20.637
21/64	.3281	8.334	53/64	.8281	21.034
11/32	.3438	8.731	27/32	.8438	21.431
23/64	.3594	9.128	55/64	.8594	21.828
3/8	.3750	9.525	7/8	.8750	22.225
25/64	.3906	9.921	57/64	.8906	22.621
13/32	.4063	10.318	29/32	.9063	23.018
27/64	.4219	10.715	59/64	.9219	23.415
7/16	.4375	11.112	15/16	.9375	23.812
29/64	.4531	11.509	61/64	.9531	24.209
15/32	.4688	11.906	31/32	.9688	24.606
31/64	.4844	12.303	63/64	.9844	25.003
1/2	.5000	12.700	1	1.0000	25.400

Gauge/Inches Conversion Chart

GAUGE	NOMINAL INCHES
0	.340"
1	.300"
2	.284"
3	.259"
4	.238"
5	.220"
6	.203"
7	.180"
8	.165"
9	.148"
10	.134"
11	.120"
12	.109"
13	.095"
14	.083"
15	.072"
16	.065"
17	.058"
18	.049"
19	.042"
20	.035"
21	.032"
22	.028"
23	.025"
24	.022"
25	.020"
26	.018"
27	.016"
28	.014"
29	.013"
30	.012"
31	.010"
32	.009"
33	.008"
34	.007"
35	.005"
36	.004"

Weight Chart for Aluminum Sheets

Painted Aluminum Sheets

GAUGE	PER SQ. FT.
.020	.300
.024	.371
.032	.471
.040	.585
.050	.726
.063	.913
.080	1.155

3000 Series - Mill Finish

GAUGE	PER SQ. FT.
.016	.227
.020	.285
.025	.356
.032	.456
.040	.570
.050	.713
.063	.891
.080	1.139
.090	1.287
.100	1.426
.125	1.782
.160	2.231
.190	2.713
.250	3.564
.375	5.346

5000 Series - Mill Finish & Anodized

GAUGE	PER SQ. FT.
.020	.282
.025	.353
.032	.452
.040	.564
.050	.706
.063	.882
.080	1.127
.090	1.274
.100	1.411
.125	1.764
.160	2.209
.190	2.685
.250	3.528
.375	5.292

Tread Plate - Diamond Plate

GAUGE	PER SQ. FT.
.063	.990
.125	1.90
.190	2.79
.250	3.67

To figure out the weight of a sheet, multiply its sq. footage by its per sq. ft. weight.

Example weight for a 48" x 96", .040 Gauge Painted Sheet

$$48 \times 96 = 4608, 4608 \div 144 = 32, 32 \times .585 = 18.72$$

Total weight for sheet is 18.72 lbs.

